



Cycle Time 

Roughness 

Position Accuracy 

True Roundness 

NineBore >>>

Nine9 offers a range of eccentrically mechanism boring tools which designed to provide stability, accuracy, and productivity in boring operations.

These tools are commonly used in industries such as automotive, aerospace, mold and die, and general machining.

99146 can complete rough and finish boring in one operation.

P M K N H

▶ **Easy Adjustment!**

▶ **No Backlash!**

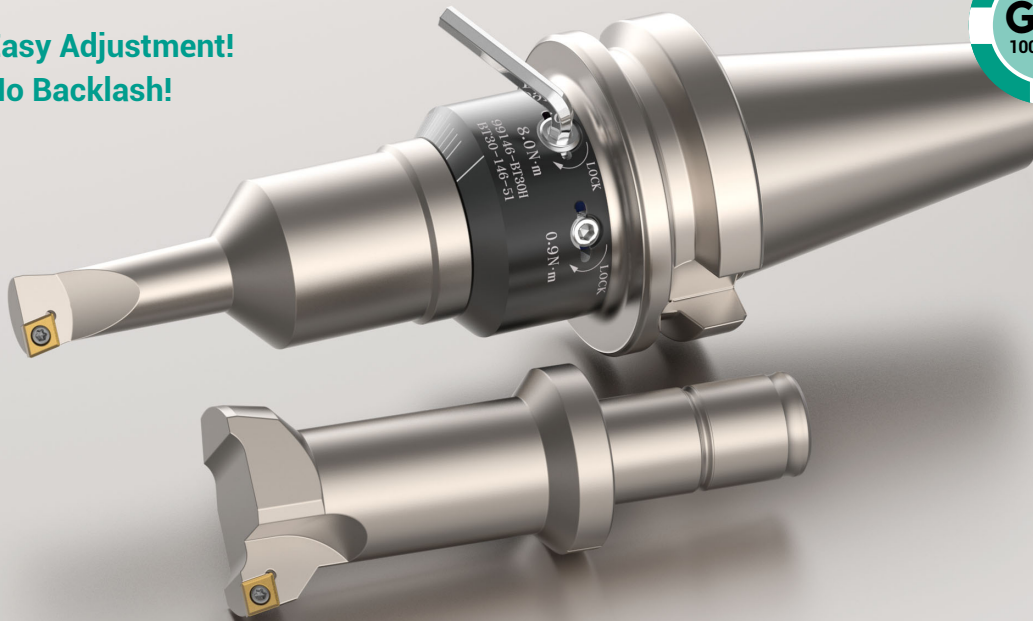

Features >>>

▶ **Easy Handling**

- Change the boring bar in just one minute.
- Dimensions are easy to read. They are indicated on the tools and are easily adjusted on a tool presetter or in machining center.
- Adjusting range :±0.1mm

▶ **High Speed.**

- Good for fine boring operation on milling machines, machining centers and special purpose machines.
- Replace solid carbide reamers.

▶ **99146 Series Is Ideal For Casting Aluminum With Uncertain Pre-Hole Dimensions And Deviations In Hole Spacing.**



Applications

Rough and finish boring in one operation

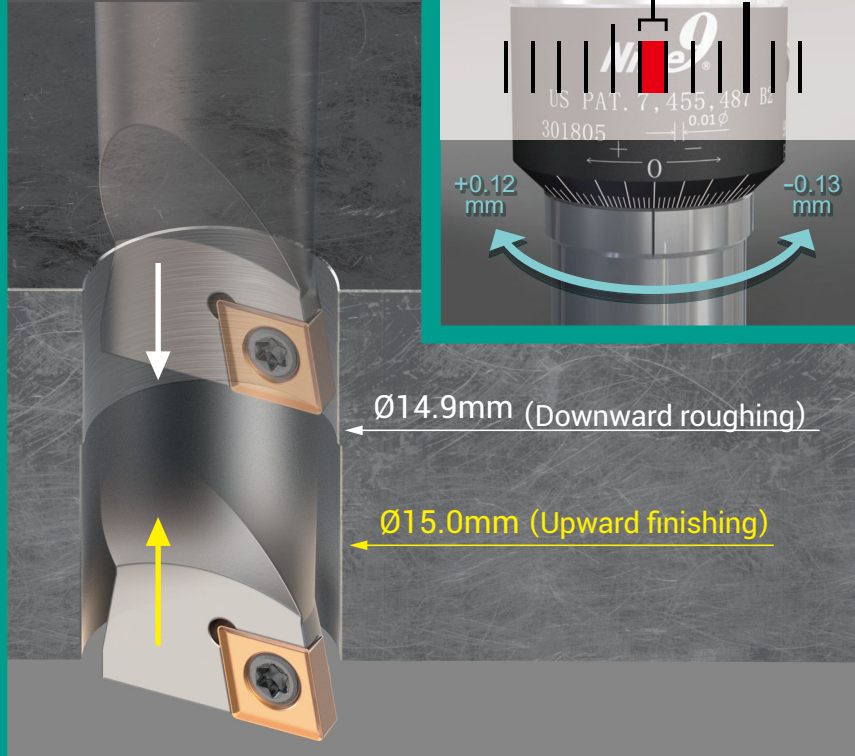

“ $\varnothing 5\sim\varnothing 50\text{mm}$ boring bars are interchangeable, balanced grade is G6.3 10000 r.p.m., all sizes are guaranteed. ”

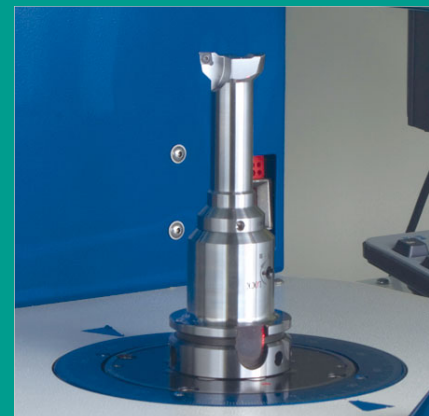

NineBore Boring Tool

9

NineBore Features

► Precisely pre-balanced the basic holder and the boring bar >>

- Balanced grade is maintained while adjusting boring dimension or change to different diameter boring bars.

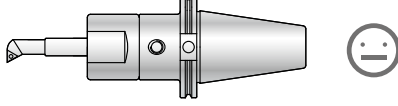
NineBore design	Other Boring Tool
	
• Pre-balanced	• Without pre-balanced

► Application >>



- Ideal as small hole boring tool with excellent accuracy.
- For fine boring operation on milling machines, machining centres and special purpose machines.

► High Speed >>









- Boring bar design ensures accurate high speed boring.
Balanced grade is G6.3 10000 r.p.m., all sizes are guaranteed.
- Combination bore / chamfer / facing / multi-task tools can be ordered on request.

► Economic >>

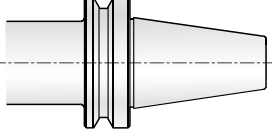
- Low cost micro adjustable boring heads.
- It can replace end mill and brazed tool bits.
- This simple boring tool has minimal components. In minutes, the boring bar can be changed and the boring dimension set on the tool presetter.

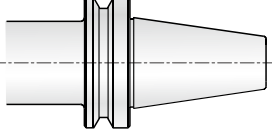
Work Task		
HoleØ : 10mm (H7 Tolerance) Hole Distance : 20mm		
Tool	NineBore 99146	Other Boring Tool
Workpiece material		N AL6061T6
CNC Code		G76
Spindle speed	r.p.m.	2500 r.p.m.
Feed rate f =	mm/rev.	0.07 mm/rev.
Feed rate F=	mm/min.	175mm/min.
RESULT		
Drilling time	sec.	10s 44
Hole 1 Ø	mm	Ø10.003 mm
Hole 2 Ø	mm	Ø9.990 mm
Hole Distance	mm	Ø19.98 mm
Comparison		

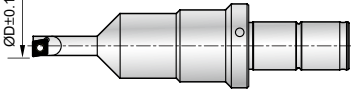
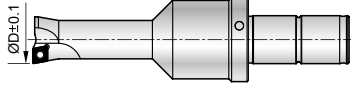
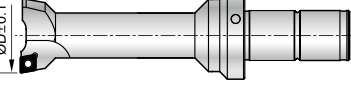
NineBore System

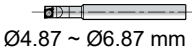
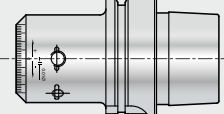
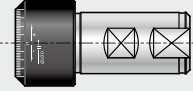
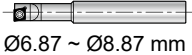
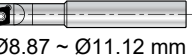
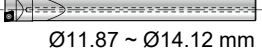
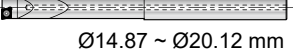
Series	Adjustment range	ØD range	Insert	Boring Bars	Head Shank
99101 Each Division 0.03 mm/div	±0.5mm	Ø 6.5 mm } 25.5 mm	 CCGT030102 CCGT040102	 00-99101-07...25	Side lock holders Hydraulic chucks Spring collet chucks 
				 00-99121-05...25	
99121 Each Division 0.01 mm/div.	±0.1mm	Ø 4.9 mm } 25.1 mm	CCGH060204	 00-99121-05...25	
G6.3 10000 r.p.m 99146 Each Division 0.01 mm/div.	+0.12mm } -0.13mm	Ø 4.87 mm } 50.12 mm	 CCGT030102 CCGT040102 CCGH060204	 Ø5 ~ Ø10 mm 00-99146-xxS	
				 Ø11 ~ Ø25 mm 00-99146-xxS	
				 Ø26 ~ Ø39 mm 00-99146-xxA	
				 Ø40 ~ Ø50 mm 00-99146-xxA	
4~6XD 99151 Each Division 0.01 mm/div.	+0.12mm } -0.13mm	Ø 4.87 mm } 20.12 mm	 CCGT030102 CCGT040102 CCGH060204	 Ø6 Ø4.87 ~ Ø6.87 mm	 00-99146-HSK63AH  00-99146-SB32H
				 Ø8 Ø6.87 ~ Ø8.87 mm	
				 Ø10 Ø8.87 ~ Ø11.12 mm	
				 Ø11 Ø11.87 ~ Ø14.12 mm	
				 Ø15.5 Ø14.87 ~ Ø20.12 mm	

99101 EMB Boring Bars 0.03 mm/div.

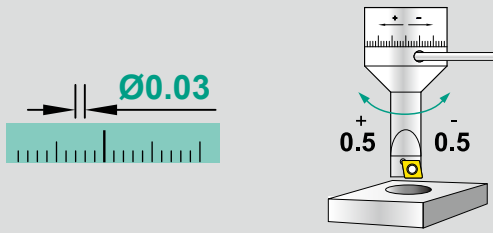

► Boring Bars >>

- Adjusted to required diameter by eccentric mechanism
- H type with internal coolant can be ordered on request from Dia. 7mm. Ordering example: 00-99101-07H.
- Other sizes are available on request.

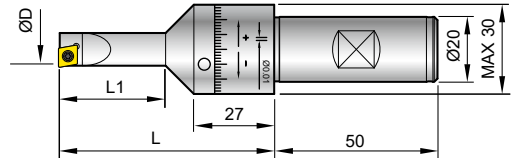

Part No.	Type		ØD	L1	L	Insert	Screw / Key
00-99101-07	SB20-0721-03	Adjustment range:±0.5mm Each Division 0.03mm	6.5-7.5	21	60	CC...040102	*NS-20036 0.6Nm / NK-T6
00-99101-08	SB20-0824-03		7.5-8.5	24	63		
00-99101-09	SB20-0927-03		8.5-9.5	27	65	CC...0602...	*NS-25045 0.9Nm / NK-T7
00-99101-10	SB20-1030-03		9.5-10.5	30	68		
00-99101-11	SB20-1133-03		10.5-11.5	33	70		
00-99101-12	SB20-1236-03		11.5-12.5	36	73		
00-99101-13	SB20-1339-03		12.5-13.5	39	75		
00-99101-14	SB20-1442-03		13.5-14.5	42	78		
00-99101-15	SB20-1545-03		14.5-15.5	45	80		
00-99101-16	SB20-1648-03		15.5-16.5	48	83	CC...0602...	*NS-25060 0.9Nm / NK-T7
00-99101-17	SB20-1751-03		16.5-17.5	51	85		
00-99101-18	SB20-1850-03		17.5-18.5	50	82		
00-99101-19	SB20-1950-03		18.5-19.5	50	82		
00-99101-20	SB20-2050-03		19.5-20.5	50	82		
00-99101-21	SB20-2150-03		20.5-21.5	50	82		
00-99101-22	SB20-2250-03		21.5-22.5	50	82		
00-99101-23	SB20-2350-03		22.5-23.5	50	82		
00-99101-24	SB20-2450-03		23.5-24.5	50	82		
00-99101-25	SB20-2550-03		24.5-25.5	50	82		

*Torque screwdriver is recommended.

99121 EMB Boring Bars 0.01 mm/div.

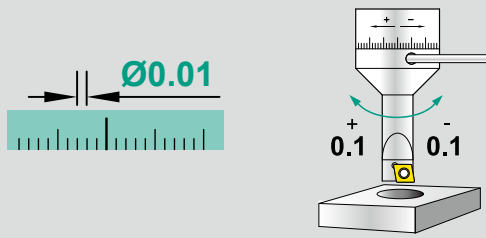

► Boring Bars >>

- Adjusted to required diameter by eccentric mechanism
- H type with internal coolant can be ordered on request from Dia. 7mm. Ordering example: 00-99121-07H.
- Other sizes are available on request.

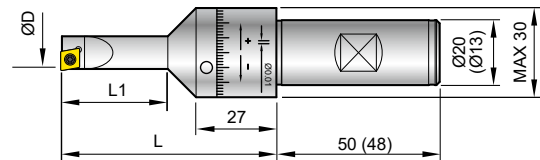

Part No.	Type		ØD	L1	L	Insert	Screw / Key		
00-99121-05	SB20-0515-01	Adjustment range:±0.1mm Each Division 0.01mm	4.9-5.1	15	54	CC...030102	*NS-16030 0.4Nm / NK-T6		
00-99121-06	SB20-0618-01		5.9-6.1	18	57				
00-99121-07	SB20-0721-01		6.9-7.1	21	60	CC...040102	*NS-20036 0.6Nm / NK-T6		
00-99121-08	SB20-0824-01		7.9-8.1	24	63				
00-99121-09	SB20-0927-01		8.9-9.1	27	65	CC...0602...	*NS-25045 0.9Nm / NK-T7		
00-99121-10	SB20-1030-01		9.9-10.1	30	68				
00-99121-11	SB20-1133-01		10.9-11.1	33	70				
00-99121-12	SB20-1236-01		11.9-12.1	36	73				
00-99121-13	SB20-1339-01		12.9-13.1	39	75				
00-99121-14	SB20-1442-01		13.9-14.1	42	78				
00-99121-15	SB20-1545-01		14.9-15.1	45	80				
00-99121-16	SB20-1648-01		15.9-16.1	48	83			CC...0602...	*NS-25060 0.9Nm / NK-T7
00-99121-17	SB20-1751-01		16.9-17.1	51	85				
00-99121-18	SB20-1850-01		17.9-18.1	50	82				
00-99121-19	SB20-1950-01		18.9-19.1	50	82				
00-99121-20	SB20-2050-01		19.9-20.1	50	82				
00-99121-21	SB20-2150-01		20.9-21.1	50	82				
00-99121-22	SB20-2250-01		21.9-22.1	50	82				
00-99121-23	SB20-2350-01		22.9-23.1	50	82				
00-99121-24	SB20-2450-01		23.9-24.1	50	82				
00-99121-25	SB20-2550-01		24.9-25.1	50	82				

*Torque screwdriver is recommended.

99146 Quick Change High Speed EMB Boring Bar

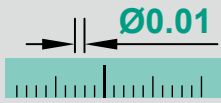

► Boring Head Shank >>

• HSK63

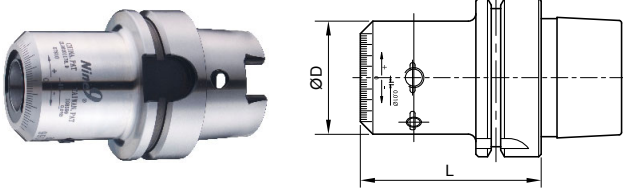

• CAT40

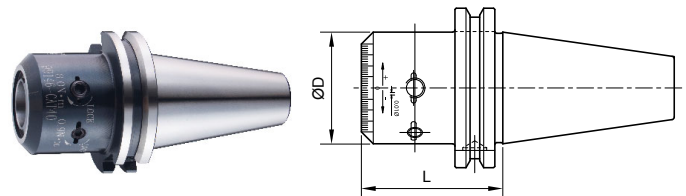

• BT

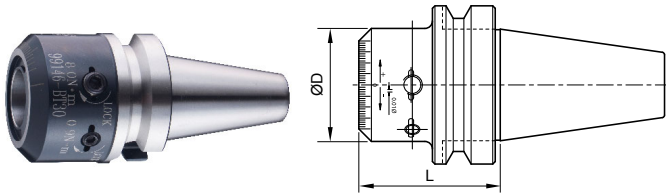

• SB32

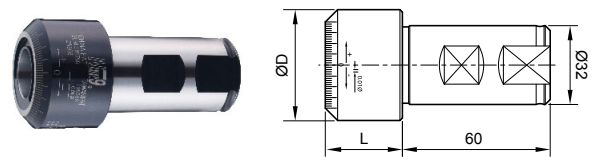

Part No.	Type	ØD	L	M8 Screw		M6 Screw	
				Spring Fingers	Locking Screw	Spring Fingers	Pre-load Screw
00-99146-HSK63AH	HSK63A-146-72	45	72.0	NP-F0002	NS-08060 8.0 Nm	NP-F0003	NS-06045 0.9 Nm
00-99146-CAT40H	CAT40-146-56	45	56.3				
00-99146-BT30H	BT30-146-51	45	51.3				
00-99146-BT40H	BT40-146-56	45	56.3				
00-99146-BT50H	BT50-146-77	45	77.3				
00-99146-SB32H	SB32-146-31	45	31.3				

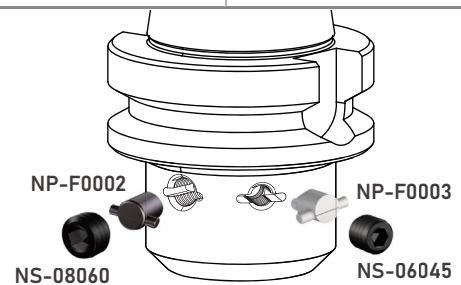

99146 Quick Change High Speed EMB Boring Bar

► Boring Bar Ø5~Ø25 >>

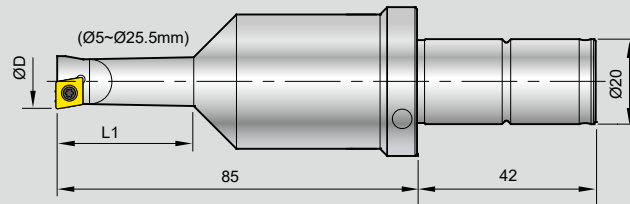

- Alloy Steel Shank. Boring Depth : L1, 2~3xD
- H type with internal coolant can be ordered on request from Dia. 10mm.
Ordering example: 00-99146-1000SH.
- Other sizes are available on request.

Part No.	Type	ØD	L1	Insert Screw / Key	Part No.	Type	ØD	L1	Insert Screw / Key
00-99146-0500S	C20-0500-10L	4.87~5.12	10.00	CC...030102 *NS-16030	00-99146-1725S	C20-1725-42L	17.12~17.37	42.50	CC...0602... *NS-25060 0.9Nm NK-T7
00-99146-0600S	C20-0600-12L	5.87~6.12	12.00	0.4Nm / NK-T6	00-99146-1750S	C20-1750-43L	17.37~17.62	43.75	
00-99146-0700S	C20-0700-14L	6.87~7.12	14.00	CC...040102 *NS-20036,	00-99146-1775S	C20-1775-43L	17.62~17.87	45.00	
00-99146-0800S	C20-0800-16L	7.87~8.12	16.00	0.6Nm / NK-T6	00-99146-1800S	C20-1800-45L	17.87~18.12		
00-99146-0900S	C20-0900-18L	8.87~9.12	18.00	CC...0602...	00-99146-1825S	C20-1825-45L	18.12~18.37	46.25	
00-99146-1000S	C20-1000-25L	9.87~10.12	25.00		00-99146-1850S	C20-1850-46L	18.37~18.62		
00-99146-1025S	C20-1025-25L	10.12~10.37			26.25	00-99146-1875S	C20-1875-46L	18.62~18.87	
00-99146-1050S	C20-1050-26L	10.37~10.62	27.50			00-99146-1900S	C20-1900-47L	18.87~19.12	
00-99146-1075S	C20-1075-26L	10.62~10.87			28.75	00-99146-1925S	C20-1925-47L	19.12~19.37	
00-99146-1100S	C20-1100-27L	10.87~11.12	30.00			00-99146-1950S	C20-1950-48L	19.37~19.62	
00-99146-1125S	C20-1125-27L	11.12~11.37			31.25	00-99146-1975S	C20-1975-48L	19.62~19.87	
00-99146-1150S	C20-1150-28L	11.37~11.62	32.50			00-99146-2000S	C20-2000-50L	19.87~20.12	
00-99146-1175S	C20-1175-28L	11.62~11.87			33.75	00-99146-2025S	C20-2025-50L	20.12~20.37	
00-99146-1200S	C20-1200-30L	11.87~12.12	35.00			00-99146-2050S	C20-2050-50L	20.37~20.62	
00-99146-1225S	C20-1225-30L	12.12~12.37		36.25	00-99146-2075S	C20-2075-50L	20.62~20.87		
00-99146-1250S	C20-1250-31L	12.37~12.62	37.50		00-99146-2100S	C20-2100-50L	20.87~21.12		
00-99146-1275S	C20-1275-31L	12.62~12.87		38.75	00-99146-2125S	C20-2125-50L	21.12~21.37		
00-99146-1300S	C20-1300-32L	12.87~13.12	40.00		00-99146-2150S	C20-2150-50L	21.37~21.62		
00-99146-1325S	C20-1325-32L	13.12~13.37		41.25	00-99146-2175S	C20-2175-50L	21.62~21.87		
00-99146-1350S	C20-1350-33L	13.37~13.62	42.50		00-99146-2175S	C20-2175-50L	21.62~21.87		
00-99146-1375S	C20-1375-33L	13.62~13.87		44.00	00-99146-2200S	C20-2200-50L	21.87~22.12		
00-99146-1400S	C20-1400-35L	13.87~14.12	45.50		00-99146-2225S	C20-2225-50L	22.12~22.37		
00-99146-1425S	C20-1425-35L	14.12~14.37		47.00	00-99146-2250S	C20-2250-50L	22.37~22.62		
00-99146-1450S	C20-1450-36L	14.37~14.62	48.50		00-99146-2275S	C20-2275-50L	22.62~22.87		
00-99146-1475S	C20-1475-36L	14.62~14.87		50.00	00-99146-2300S	C20-2300-50L	22.87~23.12		
00-99146-1500S	C20-1500-37L	14.87~15.12	51.50		00-99146-2325S	C20-2325-50L	23.12~23.37		
00-99146-1525S	C20-1525-37L	15.12~15.37		53.00	00-99146-2350S	C20-2350-50L	23.37~23.62		
00-99146-1550S	C20-1550-38L	15.37~15.62	54.50		00-99146-2375S	C20-2375-50L	23.62~23.87		
00-99146-1575S	C20-1575-38L	15.62~15.87		56.00	00-99146-2400S	C20-2400-50L	23.87~24.12		
00-99146-1600S	C20-1600-40L	15.87~16.12	57.50		00-99146-2425S	C20-2425-50L	24.12~24.37		
00-99146-1625S	C20-1625-40L	16.12~16.37		59.00	00-99146-2450S	C20-2450-50L	24.37~24.62		
00-99146-1650S	C20-1650-41L	16.37~16.62	60.50		00-99146-2475S	C20-2475-50L	24.62~24.87		
00-99146-1675S	C20-1675-41L	16.62~16.87		62.00	00-99146-2500S	C20-2500-50L	24.87~25.12		
00-99146-1700S	C20-1700-42L	16.87~17.12	63.50		00-99146-2525S	C20-2525-50L	25.12~25.37		
					00-99146-2550S	C20-2550-50L	25.37~25.62		

*Torque screwdriver is recommended.

99146 Quick Change High Speed EMB Boring Bar

▶ Boring Bar Ø26~Ø39 >>

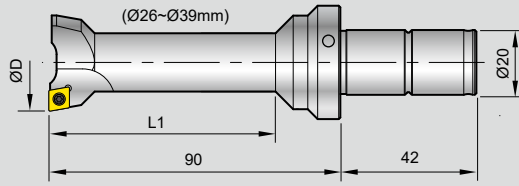

▶ Boring Bar Ø40~Ø50 >>

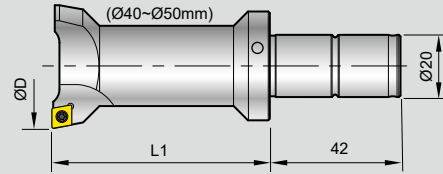

- Alloy Steel Shank. Boring Depth : L1, 2~3xD
- H type with internal coolant can be ordered on request from Dia. 10mm.
Ordering example: 00-99146-36AH.
- Other sizes are available on request.

Part No.	Type	ØD	L1	Insert Screw / Key	Part No.	Type	ØD	L1	Insert Screw / Key
00-99146-26A	C20-2600-50L	25.87~26.12	50	CC...0602...	00-99146-40A	C20-4000-70L	39.87~40.12	70	CC...0602...
00-99146-27A	C20-2700-50L	26.87~27.12			00-99146-41A	C20-4100-70L	40.87~41.12		
00-99146-28A	C20-2800-50L	27.87~28.12			00-99146-42A	C20-4200-70L	41.87~42.12		
00-99146-29A	C20-2900-50L	28.87~29.12			00-99146-43A	C20-4300-70L	42.87~43.12		
00-99146-30A	C20-3000-50L	29.87~30.12			00-99146-44A	C20-4400-70L	43.87~44.12		
00-99146-31A	C20-3100-70L	30.87~31.12			00-99146-45A	C20-4500-70L	44.87~45.12		
00-99146-32A	C20-3200-70L	31.87~32.12	*NS-25060 0.9Nm	00-99146-46A	C20-4600-70L	45.87~46.12	*NS-25060 0.9Nm		
00-99146-33A	C20-3300-70L	32.87~33.12		00-99146-47A	C20-4700-70L	46.87~47.12			
00-99146-34A	C20-3400-70L	33.87~34.12		00-99146-48A	C20-4800-70L	47.87~48.12			
00-99146-35A	C20-3500-70L	34.87~35.12		00-99146-49A	C20-4900-70L	48.87~49.12			
00-99146-36A	C20-3600-70L	35.87~36.12		00-99146-50A	C20-5000-70L	49.87~50.12			
00-99146-37A	C20-3700-70L	36.87~37.12							
00-99146-38A	C20-3800-70L	37.87~38.12							
00-99146-39A	C20-3900-70L	38.87~39.12							

*Torque screwdriver is recommended.

▶ High Speed Boring Bar Kit >>

Part No.	Contents
00-99146-SB32H-05SET	SB32-146-31 Weldon Shank
00-99146-BT30-05SET	BT30H Boring head shank
00-99146-BT40-05SET	BT40H Boring head shank
00-99146-BT50-05SET	BT50H Boring head shank
00-99146-CAT40-05SET	CAT40H Boring head shank
00-99146-HSK63A-05SET	HSK63A Boring head shank

Boring head shank: 1pc
Boring bar: any 5 pcs from Ø5~Ø50
Key: 3~5 pcs
Plastic box: 1pc



- (Insert is not included, please order separately)
- Note: BT50 boring head shank is packed in a separate box.

Application Example

► Machining a cover of scooter engine:

Workpiece material:
Die casting, Al-alloy, ADC-12(A383)
Spindle Size: BT40

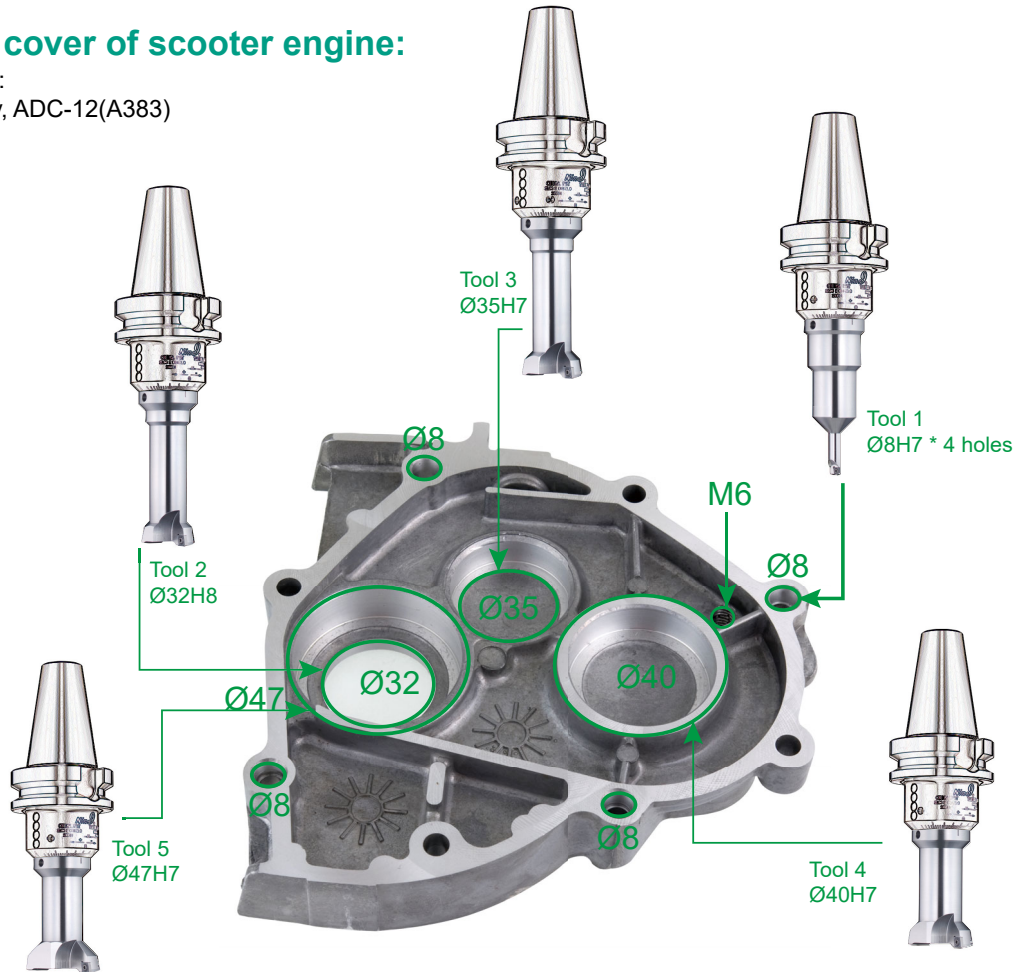

TOOL LIST by Nine9 Boring Bar 99146-series :

No.	Boring Bar	Grade of insert	Dia. mm	Depth	r.p.m.	F = mm/min.	Machining time
1	00-99146-08A	CCGT040102 NC30	Ø8H7	8 mm	8000	400	1.2 sec.
2	00-99146-32A	CCFT060204HP NC9031	Ø32H8	8 mm	2985	209	2.3 sec.
3	00-99146-35A		Ø35H7	12 mm	2730	191	3.8 sec.
4	00-99146-40A		Ø40H7	15 mm	2400	168	5.4 sec.
5	00-99146-47A		Ø47H7	15 mm	2030	142	6.4 sec.

► Example >>

Material	Vc m/min.	f mm/rev.	Roughness			Tool holder	Insert
			Ra	Rz	Rmax		
Al alloy, 6061	150	0.2	0.076µm	0.50µm	0.6µm	99146-BT40-26A	CCGH0602U NC9036

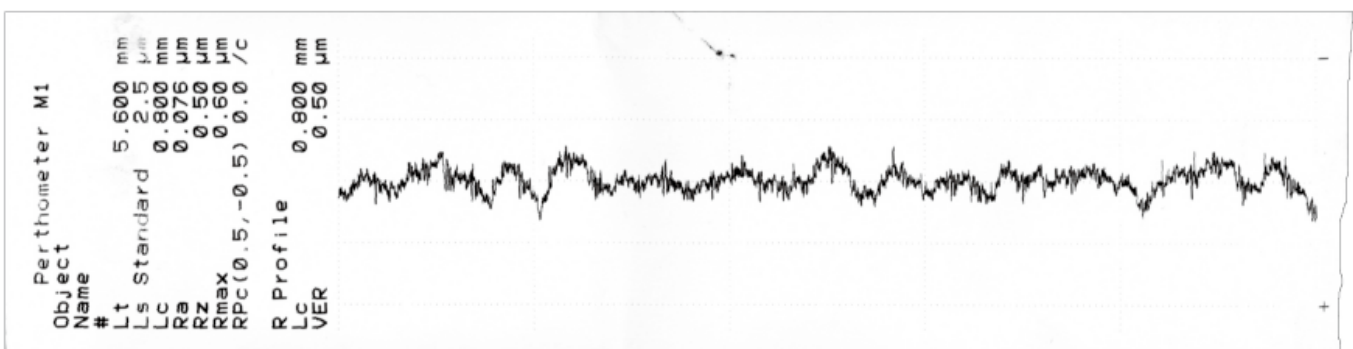

99151 Deep hole boring 4~6XD



► 99151 System >>

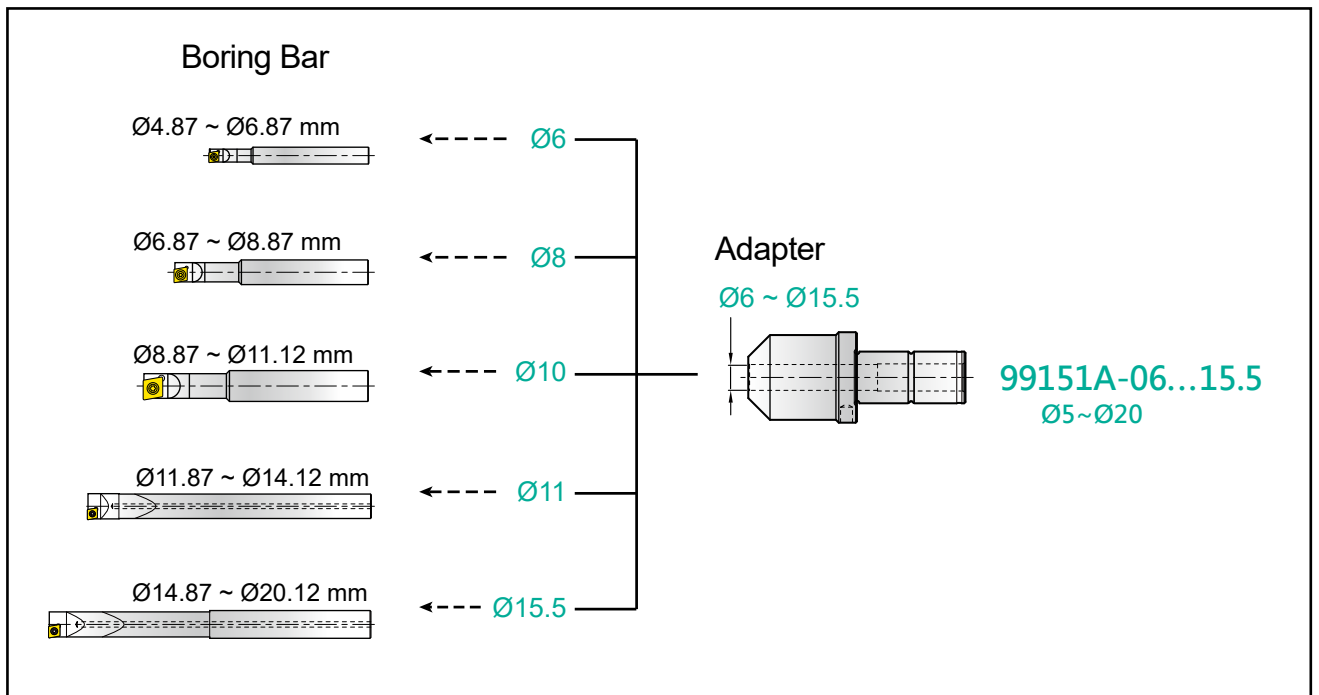

► Adapter >>

- Economical solution of small dia. boring bar.

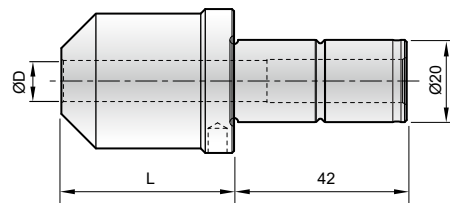

Part No.	Type	ØD	L
00-99151A-06	C20-ID06	6	52
00-99151A-08	C20-ID08	8	49
00-99151A-10	C20-ID10	10	42
00-99151A-11	C20-ID11	11	21.5
00-99151A-15.5	C20-ID15.5	15.5	21.5

99151 Deep hole boring 4~6XD

► Boring Bar Ø5~Ø20 >>

- Solid Carbide Shank
- Boring Depth : L1, 4~6xD

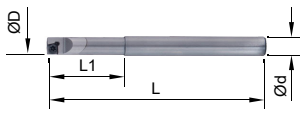
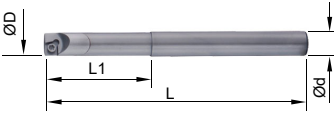
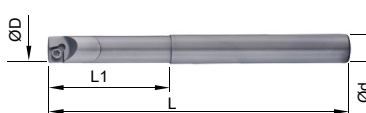
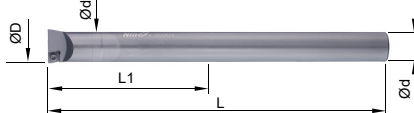
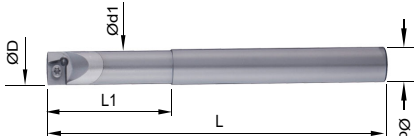
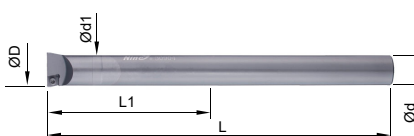
Part No.	Type	ØD	Ød	Ød1	L1	L	Insert Screw / Key	Fig.
00-99151-0500W	C06-0500-20L	4.87~5.12	6	-	20	70	CCGT030102 *NS-16030 / 0.4Nm NK-T6	
00-99151-0525W	C06-0525-20L	5.12~5.37		-				
00-99151-0550W	C06-0550-22L	5.37~5.62		-				
00-99151-0575W	C06-0575-22L	5.62~5.87		-				
00-99151-0600W	C06-0600-24L	5.87~6.12		-				
00-99151-0625W	C06-0625-24L	6.12~6.37		-				
00-99151-0650W	C06-0650-26L	6.37~6.62		-				
00-99151-0675W	C06-0675-26L	6.62~6.87		-				
00-99151-0700W	C08-0700-28L	6.87~7.12	8	-	28	85	CCGT040102 *NS-20036 / 0.6Nm NK-T6	
00-99151-0725W	C08-0725-28L	7.12~7.37		-				
00-99151-0750W	C08-0750-30L	7.37~7.62		-				
00-99151-0775W	C08-0775-30L	7.62~7.87		-				
00-99151-0800W	C08-0800-32L	7.87~8.12		-				
00-99151-0825W	C08-0825-32L	8.12~8.37		-				
00-99151-0850W	C08-0850-34L	8.37~8.62		-				
00-99151-0875W	C08-0875-34L	8.62~8.87		-				
00-99151-0900W	C10-0900-36L	8.87~9.12	10	-	36	110	CC...0602... *NS-25045 / 0.9Nm NK-T7	
00-99151-0925W	C10-0925-36L	9.12~9.37		-				
00-99151-0950W	C10-0950-38L	9.37~9.62		-				
00-99151-0975W	C10-0975-38L	9.62~9.87		-				
00-99151-1000W	C10-1000-40L	9.87~10.12		-				
00-99151-1025W	C10-1025-40L	10.12~10.37		-				
00-99151-1050W	C10-1050-42L	10.37~10.62		-				
00-99151-1075W	C10-1075-42L	10.62~10.87		-				
00-99151-1100W	C10-1100-44L	10.87~11.12	-					
00-99151-1200WS	C11-1200-120L	11.87~12.12	11	11	70	120	CC...0602... *NS-25045 / 0.9Nm	
00-99151-1300WS	C11-1300-120L	12.87~13.12		-				
00-99151-1400WS	C11-1400-120L	13.87~14.12		-				
00-99151-1500W	C15.5-1500-180L	14.87~15.12	15.5	14	90	180	NK-T7	
00-99151-1600W	C15.5-1600-180L	15.87~16.12	15.5	15	90	180	CC...0602... *NS-25060 / 0.9Nm	
00-99151-1700W	C15.5-1700-180L	16.87~17.12		-				
00-99151-1800W	C15.5-1800-180L	17.87~18.12		-				
00-99151-1900W	C15.5-1900-180L	18.87~19.12		-				
00-99151-2000W	C15.5-2000-180L	19.87~20.12		-				

*Torque screwdriver is recommended.

Procedures For Assembly

1. Use 4 mm allen-key to **loosen locking screw M8**, take care not to remove the screw.
2. Use 3 mm allen-key to **loosen pre-load screw M6**, take care not to remove the screw.
3. Remove the original boring bar and insert the new boring bar.
4. **Tighten the M6 pre-load screw**. Recommended torque = 0.9 ~ 1.0Nm.
5. Measure the boring diameter of the boring bar using tool presetter and adjust it to the required diameter.
6. **Tighten the M8 locking screw**. Recommended torque = 8 ~ 9Nm.

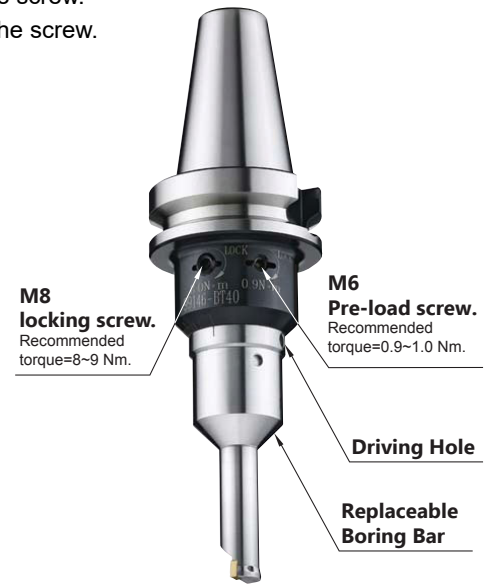
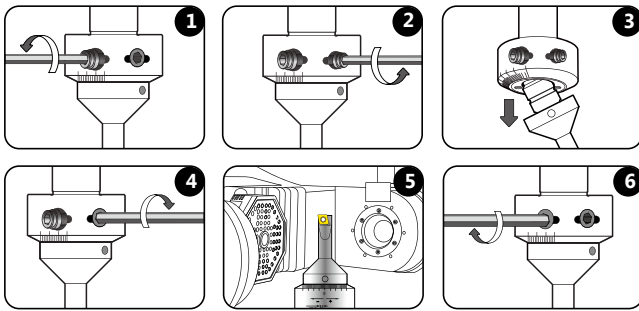

Procedures For Adjustment

On Tool Presetter

1. Loosen M8 locking screw.
2. Set the boring bar at the neutral position. (Step 1)
3. Measure the boring diameter using the tool presetter and compare with the required diameter. (Step 2)
4. If boring diameter is too big or too small, please put an allen-key into the adjusting driving hole. Turn to “ + ” to increase and turn to “ - ” to reduce boring diameter. (Step 3 and 4)
5. Tighten M8 locking screw.

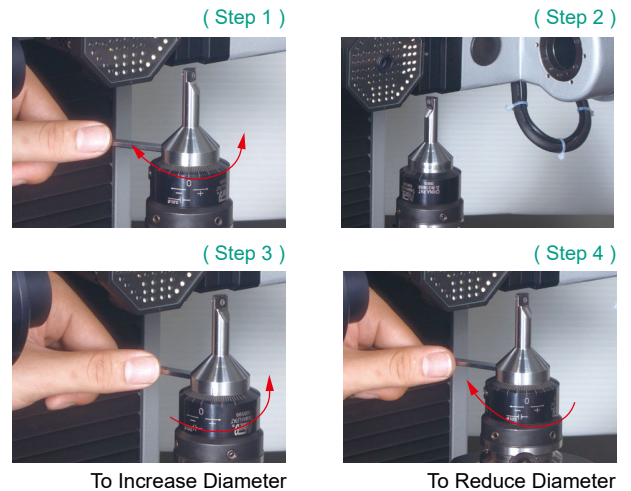

On Milling Machine and Machining Centers

1. Set the boring bar at the neutral position. (Step 1)
2. Tighten M8 locking screw.
3. Test cut on work piece, about 3-5mm depth on the machine.
4. Measuring boring diameter of workpiece and compare with required diameter.
5. If boring diameter is too big or too small, loosen M8 locking screw, please put an allen-key into the adjusting driving hole. Turn to “ + ” to increase and turn to “ - ” to reduce boring diameter. (Step 2 and 3)
6. Tighten M8 locking screw. (Step 4)

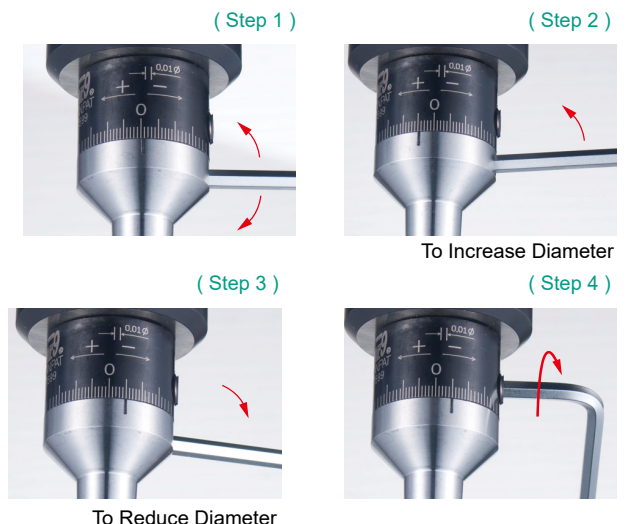

Precisely Ground Inserts

- NC30** : • Universal grade for casting iron, carbon steel, alloy steel, stainless steel.
- NC2032** : • For high speed cutting of casting iron.
- NC2033** : • Good for carbon steel, alloy steel, stainless steel.
- NC9036** : • long tool life.
 - Good for Al, Al-alloy, Copper and non-ferrous metal.
- U-XP9001** : • Super finishing insert with special specified cutting width 0.15mm radius for high feed rate.
 - Good for Al, Al-alloy and non-ferrous metal.

Parts No.	Coating	Grade		Dimensions			Screw	Key
				lc	S	Re		
CCGT030102	NC30	TiAlN	K20F	3.5	1.4	0.2	*NS-16030 0.4Nm	NK-T6
	NC9036	DLC						
CCGT040102	NC30	TiAlN	K20F	4.3	1.8	0.2	*NS-20036 0.6Nm	NK-T6
	NC9036	DLC						
CCGH0602U	U-XP9001	Uncoated	K20F			-		
CCFT060204	NC2033	TiAlN	K20F	6.35	2.38	0.4	*NS-25045 0.9Nm	NK-T7
	NC9036	DLC						
CCFW060204	NC2032	AlTiN	K20F			0.4		

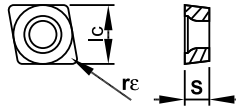

*Torque screwdriver is recommended.

Cutting Data

Spindle speed $S = \frac{V_c \times 1000}{\pi \times D}$ r.p.m. Feed rate: $f \times S$ mm/min.

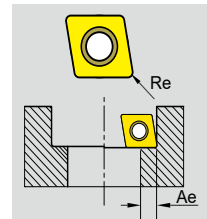

Workpiece Material	Cutting conditions or surface finishes	Cutting Speed Vc(m/min.)	feed rate f (mm/rev.)	Re0.2	Re0.4	Grade of Insert
				Ae (mm)		
P Carbon Steel	Regular cutting	120-150-200	0.05-0.07-0.10	0.05	0.1	NC2033
	Interrupted cutting	100-120-140	0.04-0.05-0.08	0.05	0.1	NC30
M Alloy Steel	Regular cutting	100-120-140	0.05-0.07-0.10	0.05	0.1	NC2033
	Interrupted cutting	80-100-120	0.04-0.05-0.08	0.05	0.1	NC30
K Stainless Steel	Regular cutting	80-100-120	0.05-0.07-0.10	0.05	0.1	NC2033
	Interrupted cutting	70-80-100	0.05-0.07-0.10	0.05	0.1	NC30
K Cast Iron	Regular cutting	80-100-120	0.05-0.07-0.10	0.05	0.1	NC2032 NC30
	Regular cutting	150-200-300	0.05-0.07-0.10	0.05	0.1	NC9036
N Brass, Bronze and Al-alloy Si >6%	Super mirror finish	150-200-300	0.15-0.2-0.25	0.15		U-XP9001
	Regular cutting	150-200-300	0.05-0.07-0.10	0.05	0.1	NC9036
N Al, Al-alloy, non-ferrous metal	Super mirror finish	150-200-300	0.15-0.20-0.25	0.15		U-XP9001
	Regular cutting	80-100-120	0.04-0.06-0.08	0.05	0.1	NC30
H Hardened Steel <HRC 50	Regular cutting	80-100-120	0.04-0.06-0.08	0.05	0.1	NC30