

Nine9®

NEAR ZER



近零耗材

No. 11



MCC

微耗材切削指標

Minimum Consumable Cutting Indicator



與一般切削刀具相比，Nine9 刀片僅使用 <5% 的碳化鎢合金原材料，但仍能獲得良好的性能。

- 可使用近20次
- 減少原材料
- 減少碳排放



 90° 星艦定位鑽，
捨棄式兩刃定位鑽 (3.5%)

使用低於 **5%** 的原料



使用低於 **10%** 的原料
90° 捨棄式單刃定位鑽 (7%)



使用低於 **30%** 的原料
90° 鎖牙型定位鑽 (13%)



使用低於 **50%** 的原料
90° 鎢鋼雙頭定位鑽



使用 **100%** 的原料
90° 單頭定位鑽



Carbon
Reduction

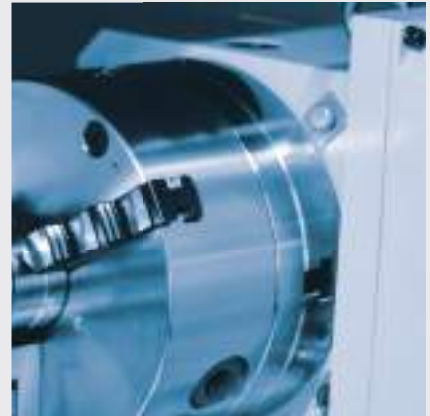

PASSION PERSEVERANCE DETERMINATION



耐久切削工具有限公司於 1994 年開始開發特殊刀具、搪刀和周邊配件，並於1999年創立 Nine9 品牌。

Nine9 來源於漢字的意思“長壽命和耐用性”~

這句話恰如其分地描述了所有 Nine9 工具。

99是2位數字的最大數，表示產品的最大耐用度。

Nine9 刀具雖然以“特殊刀具”開始於業界，

但我們也發展了許多標準規格刀具，例如: NC 車銑萬用鑽，超倍比鑽頭，

高速搪刀，雕刻刀、捨棄式中心鑽、電腦打洞刀、密齒倒角刀....等

這些特殊的標準規格刀具確立了 Nine9 是作為捨棄式刀具市場的領導者與創新者。

創新專利

耐久切削工具有限公司，台灣捨棄式切削刀具品牌，致力於研發特殊刀具與零件，為客戶帶來雙贏，永續發展的價值。耐久創立至今已擁有超過百項專利，是切削刀具結構創新、規格制定者，為顧客提供高精度、高效率、高品質的切削刀具。

產品研發里程碑



創立於1994年，
致力於研發特殊刀具與零件

- 小孔徑精搪刀
- 標準高效能刀具系列



NC車銑萬用鑽-CT系列上市



快換式搪刀系統上市



刀霸系列-銑刀上市



NC車銑萬用鑽-PR系列上市



圓弧倒角刀 & 超倍比鑽頭上市



1994

1995

2001

2002

2004

2005

2006

US 7,431,517 B2
US 7,455,407 B2
US 8,192,114 B2
US 9,579,812 B2
US 9,718,137 B2
US 9,764,396 B2

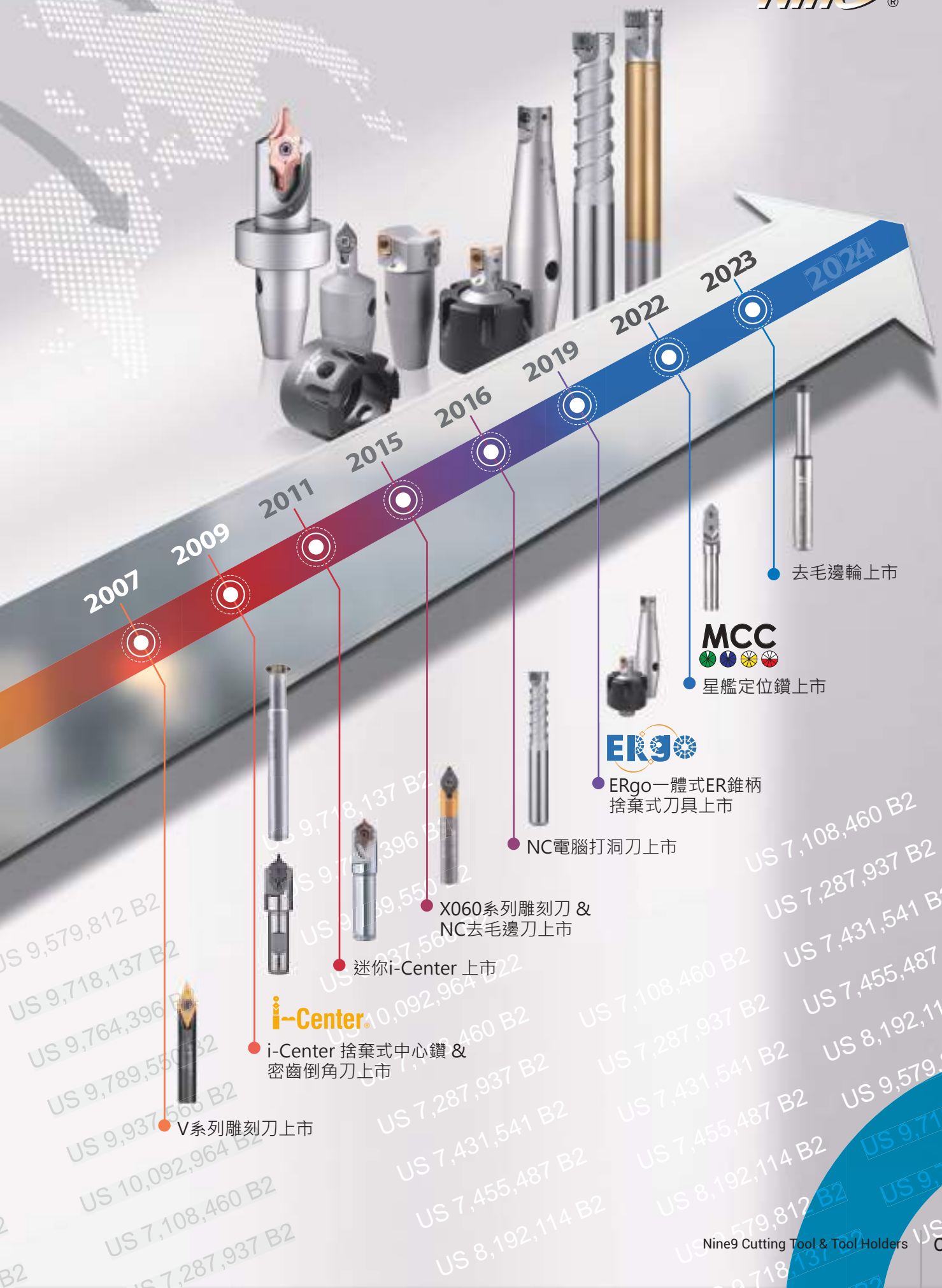



星艦定位鑽 | 60° / 90° / 120° / 142°



中心孔



埋頭孔

高精度、中心出水、高效率

- 高剛性、HPC高性能切削、超長刀具壽命
- 4 個角度：60° / 90° / 120° / 142°
- 對稱的切削刃設計，減少側向力
- 雙螺絲設計確保切削過程中無振動



微型定位鑽 | 90° / 120° / 142°



中心孔

0.1 和 0.2mm 底部寬

- 為微型鑽頭進入工件時提供一致的表面，特別是適用於圓形、有角度或彎曲的表面。
- 改善深孔鑽的孔位置或微型鑽的刀具壽命。
- 高效率！ 刀具壽命長！ 節省成本！



NC 車銑萬用鑽 | 60° ~ 145°



中心孔



倒角



車端面



雕刻



車槽

多功能刀具

- 使用捨棄式刀片
- 高效率、低成本
- 適用CNC車床、車銑中心機及切削中心機
- 捨棄式鍍層刀片增加切削效率



圓弧倒角刀 | RC0.5 ~ 10.0mm



多款不同圓弧倒角刀片可裝置在標準刀桿上

- 刀片角度與定位精準，增加刀具壽命
- 加工表面卓越，圓弧加工曲線優異
- 同一刀片可圓弧倒角及45°倒角
- 高切削速度，進給率快





中心鑽 « i-Center »



導引尺寸
1~10mm



刀具壽命長、無須重新設定刀具長度

- 優異的重現性，重現度0.02mm
- 縮短設定時間，減少加工工時
- 刀長誤差值於±0.05mm以內
- 中心出水型



雕刻刀 | 30° / 45° / 60° / 90° / 120° / 142°



角度選擇多! 無毛邊!

- 全研磨刀片，雕刻表面優異、高速切削
- 無須重新設定刀具長度
- 廣泛應用於機械產業、醫療產業、國防產業、模具產業、汽機車產業、齒輪、軸承及精品產業



NC 去毛邊刀 | 60° / 90°



6個切削刃! 6倍高進給率!

- 精修毛邊
- 最小倒角直徑Ø0.5mm
- 高速度、高進給去除毛邊
- 加工深度與尺寸定位精準



NC 去毛邊輪 | 55° / 60° / 90°

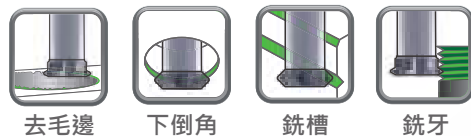

正反去毛邊, 55°, 60° 去毛邊也適合銑牙

- 6個切削刃、高速度、高進給去除毛邊
- 最小去毛刺孔從 Ø3.8mm 到 Ø10mm。
- 加工深度與尺寸定位精準



密齒倒角刀 | 45°



倒角



面銑



反向倒拉倒角



內孔倒角

可同時加工前倒角和背倒角。高速度、高進給

- 最小倒角刀片
- 最小倒角尺寸 $\varnothing 7\text{mm}$
- 可增加4-10倍的倒角效率
- 密集刀刃數設計，最高倒角進給、雙角度倒角刀片與耐磨鍍層



NC 電腦打洞刀 | $\varnothing 13\text{mm} \sim \varnothing 65\text{mm}$



兩種刀桿

NC電腦指令加工、除料性能優異

- 螺旋加工切削最大下降角度為 20°
- 6支刀具就可加工 $\varnothing 13\text{mm} \sim \varnothing 65\text{mm}$ 尺寸
- 碎片狀切屑、適用於長屑型的軟性材料
- 卓越刀具設計，加工操作容易



超倍比鑽頭 | 5xD ~ 10xD



特殊設計增加
中心定位精準度

5~10xD : $\varnothing 19 \sim \varnothing 40\text{mm}$ 最大倍比可達12xD

- 專利刀座設計，中心導引定位精準
- 自我中心導引加工使切屑呈螺旋小碎屑
- 加工表面優異，減少加工時間
- 專利刀片座設計，可吸收切削阻力



真好鑽 | 3xD & 4xD

3xD : $\varnothing 10 \sim \varnothing 30\text{mm}$

4xD : $\varnothing 16 \sim \varnothing 30\text{mm}$

最小尺寸從10mm開始

- 內外刃可用同一款刀片
- 內刃、外刃分割切屑，切削快速、排屑容易
- 加工表面優異，尺寸穩定
- 不需預加工平面，就可直接鑽孔





刀霸系列-銑刀 | Ø10 ~ Ø315mm



捨棄式刀頭最小尺寸10mm，高耐磨特性

- 專利雙角度刀片設計，刀片角度精準，銑削加工安定
- 高強度設計，適用於高正角切削
- 表面加工優異、適用於精修
- 兩種刀柄選擇: 鎖牙式&直柄式



高速搪刀 | Ø5mm~Ø50mm



尺寸調整容易、無背隙問題! G6.3/10,000r.p.m

- 萬轉搪刀，調整範圍:±0.1mm
- Ø5mm~Ø50mm尺寸可自行更換
- 小孔徑加工精度優異，適用於銑床加工、中心機、特殊加工機
- 取代鎢鋼絞刀



ERgo 系統 | ER11 / ER16 / ER20 / ER25



一體式ER錐柄捨棄式刀具

- 提高刀具的強度與壽命
- 快速換刀，節省大量換刀時間
- 使用簡單、組裝快速
- 優異的重現性，節省設定時間

ERgo 系統包含: 刀霸銑刀，NC 車銑萬用鑽，圓弧倒角刀，雕刻刀，去毛邊刀，密齒倒角刀，中心鑽以及搪刀。



配件

延長桿

- 鋼柄與鎢鋼接桿



0
1
2
3
4
5
6
7
8
9
10
11
12
13
14
15
16
17
18
19
20
21
22
23
24
25
26
27

“Awarded **PATENTS**”

*No Need To Choose
Nine9 Does It All!*



CREATIVITY

US 7,108,460 B2

US 7,287,937 B2

US 7,431,541 B2

US 7,455,487 B2

US 8,192,114 B2

US 9,579,812 B2

US 9,718,137 B2

US 9,764,396 B2

US 9,789,550 B2

US 9,937,566 B2

US 10,092,964 B2

US 11,583,941 B2



目錄索引

	Group	Page
1 SERIES	星艦定位鑽	1-12
2 SERIES	■ 微型定位鑽 / NC 車銑萬用鑽	2-20
	■ 圓弧倒角刀	2-36
	■ i-Center 中心鑽	2-48
3 SERIES	雕刻刀	3-62
4 SERIES	■ NC 去毛邊刀	4-76
	■ 捨棄式去毛邊輪	4-78
	■ 密齒倒角刀	4-84
5 SERIES	電腦打洞刀	5-90
6 SERIES	超倍比鑽頭	6-104
	真好鑽	6-116
7 SERIES	刀霸銑刀	7-122
8 SERIES	搪刀	8-140
9 SERIES	ERgo ER 錐柄切削刀具	9-170

星艦定位鑽



定點概念

鑽孔前先使用定位鑽打出小孔，可防止鑽頭打偏，讓後續鑽孔孔位更為精準。理想情況下，適當的定位鑽角度應該比鑽頭的角度要大，使鑽頭的中心點是接觸工件的第一個點，以此避免鑽頭在開始鑽孔時走動或移動。

P M K N

▶ 雙螺絲固定設計

- 讓刀片鎖固力加倍，更能對抗斷續切削。



Features >>>

▶ 提供 4 種角度刀片：60° / 90° / 120° / 142°

<p>60°</p> <p>• 適合 60° 鑽頭。</p>	<p>90°</p> <p>• 適合 90° 鑽頭。</p>	<p>120°</p> <p>• 適合 118° 鑽頭鑽孔前的定位。</p>	<p>142°</p> <p>• 適合 135° ~ 140° 高性能鑽頭鑽孔前的定位。</p>
---------------------------------------	---------------------------------------	---	---

▶ 優異的刀片重現性，更換刀片不用重新設定刀具長度

▶ 高剛性、高性能、超長刀具壽命!

- 對稱切削刃大幅減少切削產生的側向推力，讓加工過程更安靜、更順暢，進給速度更加倍。
- 雙角度刀尖使刀片尖端更堅固，從而延長使用壽命，進而降低生產成本。



Applications

可使用最小限度潤滑 (MQL)
時進行鑽孔

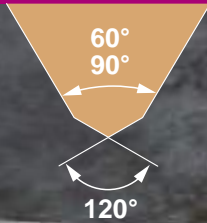

▶ 雙角度刀尖
• 確保中心強度，防止刀尖斷裂。

中心出水

• 優化的冷卻設計可
實現更好的平衡。



雙切削刃

• 對稱設計



中心孔

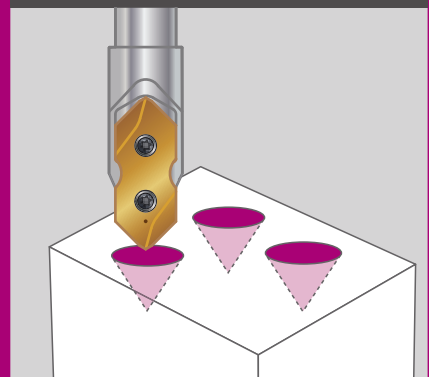

“ Nine9 定位鑽可改善孔洞位置度、
提高鑽頭進給速度、延長刀具壽命、
提高生產效率並確保均勻的孔洞
品質。 ”

星艦定位鑽 - 刀片

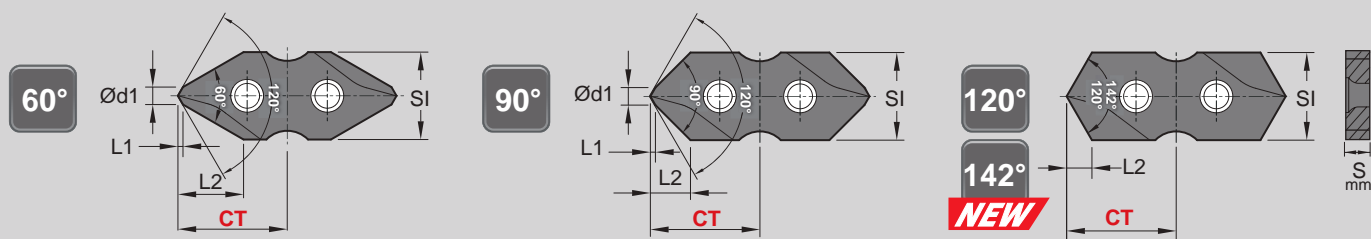

1

星艦定位鑽

▶ 刀片 >>

- NC2057:** • 適用鋼料、鑄鐵
• 刀片有2個切削刃口
- NC5254:** • 適用不銹鋼，不產生毛邊
• 刀片有2個切削刃口
- XP9000:** • 適用非鐵金屬、鋁合金、銅合金、塑膠、壓克力
• 刀片有2個切削刃口

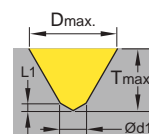

SI	角度 ±0.5	訂購編號	鍍層	材質	尺寸			Dmax.	Tmax.	S	CT ±0.025	
					Ød1	L1	L2					
06	60°	S9MT06T1-060	NC2057	AlTiN+TiSiN	1.2	0.35	4.5	5.5	4.1	1.8	7.5	
			NC5254	Helica								
			XP9000	Uncoated								
	90°	S9MT06T1-090	S9MT06T1-090	NC2057	AlTiN+TiSiN	1.2	0.35	2.75	5.5	2.5	1.8	7.5
				NC5254	Helica							
				XP9000	Uncoated							
	120°	S9MT06T1-120	S9MT06T1-120	NC2057	AlTiN+TiSiN	-	-	1.73	5.5	1.6	1.8	7.5
				NC5254	Helica							
				XP9000	Uncoated							
	142°	S9MT06T1-142	S9MT06T1-142	NC2057	AlTiN+TiSiN	-	-	1.03	5.5	0.95	1.8	7.0
				NC5254	Helica							
				XP9000	Uncoated							
08	60°	S9MT0802-060	NC2057	AlTiN+TiSiN	1.6	0.46	6.0	7.5	5.6	2.4	10	
			NC5254	Helica								
			XP9000	Uncoated								
	90°	S9MT0802-090	S9MT0802-090	NC2057	AlTiN+TiSiN	1.6	0.46	3.6	7.5	3.4	2.4	10
				NC5254	Helica							
				XP9000	Uncoated							
	120°	S9MT0802-120	S9MT0802-120	NC2057	AlTiN+TiSiN	-	-	2.3	7.5	2.2	2.4	10
				NC5254	Helica							
				XP9000	Uncoated							
	142°	S9MT0802-142	S9MT0802-142	NC2057	AlTiN+TiSiN	-	-	1.38	7.5	1.29	2.4	9
				NC5254	Helica							
				XP9000	Uncoated							
10	60°	S9MT1003-060	NC2057	AlTiN+TiSiN	2	0.58	7.5	9.5	7.1	3.0	12.50	
			NC5254	Helica								
			XP9000	Uncoated								
	90°	S9MT1003-090	S9MT1003-090	NC2057	AlTiN+TiSiN	2	0.58	4.6	9.5	4.4	3.0	12.50
				NC5254	Helica							
				XP9000	Uncoated							
	120°	S9MT1003-120	S9MT1003-120	NC2057	AlTiN+TiSiN	-	-	2.9	9.5	2.7	3.0	12.50
				NC5254	Helica							
				XP9000	Uncoated							
	142°	S9MT1003-142	S9MT1003-142	NC2057	AlTiN+TiSiN	-	-	1.72	9.5	1.64	3.0	11.50
				NC5254	Helica							
				XP9000	Uncoated							

每盒刀片數量：
 SI 06 5片 SI 08 5片 SI 10 5片 SI 12 5片 SI 16 2片 SI 20 1片

星艦定位鑽 - 刀片

▶ 刀片 >>

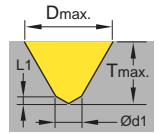

SI	角度 ±0.5	訂購編號	鍍層	材質	尺寸			Dmax.	Tmax.	S	CT ±0.025
					Ød1	L1	L2				
12	60°	S9MT1203-060	NC2057	AlTiN+TiSiN	2.4	0.69	9.0	11.5	8.6	3.0	15
			NC5254	Helica							
			XP9000	Uncoated							
	90°	S9MT1203-090	NC2057	AlTiN+TiSiN	2.4	0.69	5.5	11.5	5.3	3.0	
			NC5254	Helica							
			XP9000	Uncoated							
	120°	S9MT1203-120	NC2057	AlTiN+TiSiN	-	-	3.5	11.5	3.3	3.0	
			NC5254	Helica							
			XP9000	Uncoated							
	142°	S9MT1203-142	NC2057	AlTiN+TiSiN	-	-	2.07	11.5	1.98	3.0	
			NC5254	Helica							
			XP9000	Uncoated							
16	60°	S9MT1603-060	NC2057	AlTiN+TiSiN	3.2	0.92	12	15.5	11.6	3.18	20
			NC5254	Helica							
			XP9000	Uncoated							
	90°	S9MT1603-090	NC2057	AlTiN+TiSiN	3.2	0.92	7.3	15.5	7.0	3.18	
			NC5254	Helica							
			XP9000	Uncoated							
	120°	S9MT1603-120	NC2057	AlTiN+TiSiN	-	-	4.6	15.5	4.4	3.18	
			NC5254	Helica							
			XP9000	Uncoated							
	142°	S9MT1603-142	NC2057	AlTiN+TiSiN	-	-	2.76	15.5	2.67	3.18	
			NC5254	Helica							
			XP9000	Uncoated							
20	60°	S9MT2004-060	NC2057	AlTiN+TiSiN	4.0	1.16	15	19.5	14.6	4.76	25
			NC5254	Helica							
			XP9000	Uncoated							
	90°	S9MT2004-090	NC2057	AlTiN+TiSiN	4.0	1.16	9.2	19.5	8.9	4.76	
			NC5254	Helica							
			XP9000	Uncoated							
	120°	S9MT2004-120	NC2057	AlTiN+TiSiN	-	-	5.8	19.5	5.6	4.76	
			NC5254	Helica							
			XP9000	Uncoated							
	142°	S9MT2004-142	NC2057	AlTiN+TiSiN	-	-	3.44	19.5	3.36	4.76	
			NC5254	Helica							
			XP9000	Uncoated							

每盒刀片數量：

SI 06	SI 08	SI 10	SI 12	SI 16	SI 20
5 片	5 片	5 片	5 片	2 片	1 片

1

星艦定位鑽

星艦定位鑽 - 刀桿



1

星艦定位鑽

▶ 直柄刀桿 >>

- 高合金製作，硬度達HRC53
- 中心出水

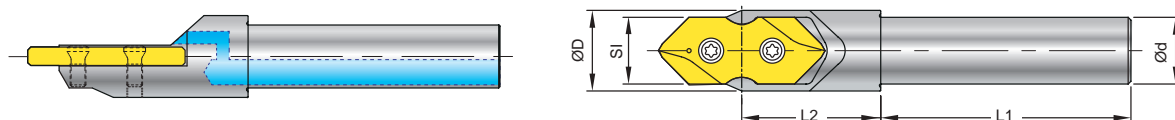

SI	訂購編號	Ød	L1	L2	ØD	螺絲	扳手
06	99688-SI06-06	6	27	14	8	NS-18037 / 0.6Nm	NK-T6
08	99688-SI08-08	8	36	19	10.5	NS-20045 / 0.6Nm	NK-T6
10	99688-SI10-10	10	40	22.5	13	NS-25060 / 0.9Nm	NK-T7
12	99688-SI12-12	12	45	25	15.5	NS-30072 / 2.0Nm	NK-T9
16	99688-SI16-16	16	48	32	21	NS-35080 / 2.5Nm	NK-T15
20	99688-SI20-20	20	50	35	26	NS-50125 / 5.5Nm	NK-T20

▶ 鎖牙型刀頭 >> **NEW**

- 高合金製作，硬度達HRC53
- 中心出水

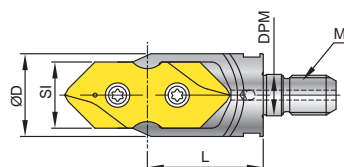

SI	訂購編號	ØD	L	M	DPM	螺絲	扳手
06	99688-SI06-M04	8	14.5	M4xP0.7	4.5	NS-18037 / 0.6Nm	NK-T6
08	99688-SI08-M05	10	19	M5xP0.8	5.5	NS-20045 / 0.6Nm	NK-T6
10	99688-SI10-M06	12	22	M6xP1.0	6.5	NS-25060 / 0.9Nm	NK-T7
12	99688-SI12-M08	16	25	M8xP1.25	8.5	NS-30072 / 2.0Nm	NK-T9
16	99688-SI16-M10	20	31	M10xP1.5	10.5	NS-35080 / 2.5Nm	NK-T15
20	99688-SI20-M12	25	35	M12xP1.75	12.5	NS-50125 / 5.5Nm	NK-T20

• 有關延長桿，請參閱第 9-189 頁。

技術規範

▶ 由中心尺寸”d”取得鑽孔深度”t”

刀片	S9MT06T1				S9MT0802				S9MT1003				S9MT1203				S9MT1603				S9MT2004			
	60°	90°	120°	142°	60°	90°	120°	142°	60°	90°	120°	142°	60°	90°	120°	142°	60°	90°	120°	142°	60°	90°	120°	142°
Tmax.	4.1	2.5	1.6	0.95	5.6	3.4	2.2	1.29	7.1	4.4	2.7	1.64	8.6	5.3	3.3	1.98	11.6	7.0	4.4	2.67	14.6	8.9	5.6	3.36
Ød1	1.2	-	-	-	1.6	-	-	-	2	-	-	-	2.4	-	-	-	3.2	-	-	-	4.0	-	-	-
L1	0.35	-	-	-	0.46	-	-	-	0.58	-	-	-	0.69	-	-	-	0.92	-	-	-	1.16	-	-	-

60°

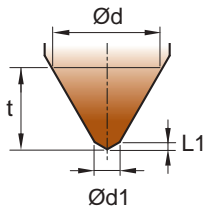

$$t = (\text{Ød} - \text{Ød1}) \times 0.866 + L1$$

90°

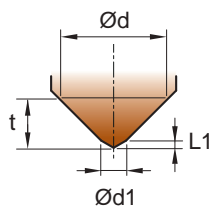

$$t = (\text{Ød} - \text{Ød1}) \times 0.5 + L1$$

120°

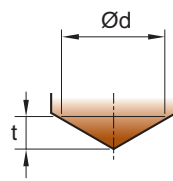

$$t = 0.289 \times \text{Ød}$$

142°

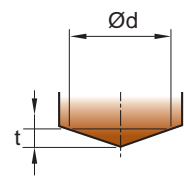

$$t = 0.172 \times \text{Ød}$$

▶ 請注意! 60° 刀片 (S9MTxxx-060) , 必須啄鑽。

步驟 1 從上面算式取得 ”t” (鑽孔深度) 。

步驟 2 計算出 T 值 (深度係數): $T = \frac{t}{T_{\text{max}}}$

步驟 3 依據工件材質, 參考表格找出 Q (每刀啄鑽深度) 。

*Q T	0.1	0.2	0.3	0.4	0.5	0.6	0.7	0.8	0.9	1.0
Material P	0.5	0.45	0.4	0.35	0.3	0.25	0.2	0.15	0.1	0.1
M	0.2	0.2	0.2	0.15	0.15	0.15	0.1	0.1	0.1	0.1
K	0.5	0.45	0.4	0.35	0.3	0.25	0.2	0.15	0.1	0.1
N	1.0	0.9	0.8	0.7	0.6	0.5	0.4	0.3	0.2	0.2

▶ 計算機台轉速及進給率

公制	
$S = \frac{Vc \times 1000}{\pi \times d}$	d = 直徑 -mm S = 刀具轉速 -r.p.m. Vc = 切削速度 -m/min.
$F = S \times f$	f = mm/rev. F = mm/min.

英制	
$S = \frac{(3.82 \times \text{SFM})}{d}$	d = 直徑 -inch S = 刀具轉速 -r.p.m. SFM = Surface Speed-ft./min.
$F = \text{r.p.m.} \times \text{IPR}$	f = IPR = inch/rev. F = inch/min.

▶ 刀片鎖固

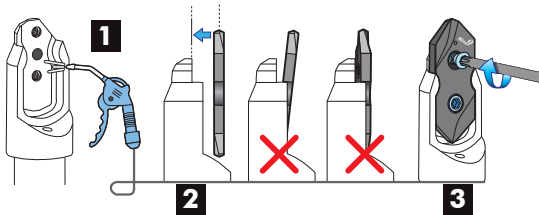

▶ 取下刀片

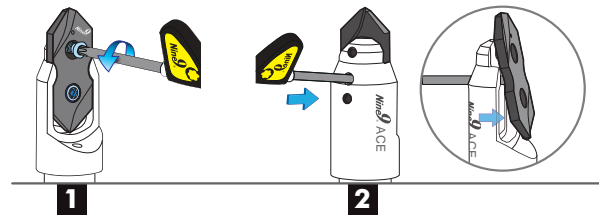

1

星艦定位鑽

切削資料

S106- S9MT06T1

工件材質	Vc (m/min)	60°	90°	120°	142°	刀片鍍層	
		Q (每刀啄鑽深度)	f (mm/rev.)				
P 低碳鋼 C<0.3% 低合金鋼 C<0.3% 中碳鋼 C>0.3% 高合金鋼 C>0.3%	120 ~ 250	0.1 ~ 0.5mm	0.01 ~ 0.05	0.02 ~ 0.08	0.02 ~ 0.10	0.02 ~ 0.10	NC5254
	100 ~ 220		0.01 ~ 0.04	0.02 ~ 0.07	0.02 ~ 0.08	0.02 ~ 0.08	
	100 ~ 200		0.01 ~ 0.05	0.02 ~ 0.08	0.02 ~ 0.10	0.02 ~ 0.10	NC2057
	80 ~ 180		0.01 ~ 0.03	0.02 ~ 0.06	0.02 ~ 0.07	0.02 ~ 0.07	
M 不鏽鋼	30 ~ 80	0.1 ~ 0.2mm	0.01 ~ 0.02	0.01 ~ 0.03	0.01 ~ 0.03	0.01 ~ 0.03	NC5254
K 鑄鐵	80 ~ 180	0.1 ~ 0.5mm	0.01 ~ 0.05	0.02 ~ 0.08	0.02 ~ 0.10	0.02 ~ 0.10	NC2057
N 鋁、非鐵金屬	150 ~ 300	0.2 ~ 1.0mm	0.01 ~ 0.06	0.03 ~ 0.10	0.03 ~ 0.12	0.03 ~ 0.12	XP9000

S108- S9MT0802

工件材質	Vc (m/min)	60°	90°	120°	142°	刀片鍍層	
		Q (每刀啄鑽深度)	f (mm/rev.)				
P 低碳鋼 C<0.3% 低合金鋼 C<0.3% 中碳鋼 C>0.3% 高合金鋼 C>0.3%	120 ~ 250	0.1 ~ 0.5mm	0.02 ~ 0.08	0.03 ~ 0.10	0.03 ~ 0.12	0.03 ~ 0.12	NC5254
	100 ~ 220		0.02 ~ 0.07	0.03 ~ 0.08	0.03 ~ 0.10	0.03 ~ 0.10	
	100 ~ 200		0.02 ~ 0.08	0.03 ~ 0.10	0.03 ~ 0.12	0.03 ~ 0.12	NC2057
	80 ~ 180		0.02 ~ 0.06	0.03 ~ 0.07	0.03 ~ 0.08	0.03 ~ 0.08	
M 不鏽鋼	30 ~ 80	0.1 ~ 0.2mm	0.01 ~ 0.03	0.01 ~ 0.04	0.01 ~ 0.04	0.01 ~ 0.04	NC5254
K 鑄鐵	80 ~ 180	0.1 ~ 0.5mm	0.02 ~ 0.08	0.03 ~ 0.10	0.03 ~ 0.12	0.03 ~ 0.12	NC2057
N 鋁、非鐵金屬	150 ~ 300	0.2 ~ 1.0mm	0.03 ~ 0.10	0.03 ~ 0.12	0.03 ~ 0.15	0.03 ~ 0.15	XP9000

S110- S9MT1003

工件材質	Vc (m/min)	60°	90°	120°	142°	刀片鍍層	
		Q (每刀啄鑽深度)	f (mm/rev.)				
P 低碳鋼 C<0.3% 低合金鋼 C<0.3% 中碳鋼 C>0.3% 高合金鋼 C>0.3%	120 ~ 250	0.1 ~ 0.5mm	0.03 ~ 0.08	0.04 ~ 0.15	0.05 ~ 0.20	0.05 ~ 0.20	NC5254
	100 ~ 220		0.03 ~ 0.07	0.03 ~ 0.12	0.05 ~ 0.15	0.05 ~ 0.15	
	100 ~ 200		0.03 ~ 0.08	0.04 ~ 0.15	0.05 ~ 0.20	0.05 ~ 0.20	NC2057
	80 ~ 180		0.02 ~ 0.06	0.03 ~ 0.10	0.04 ~ 0.12	0.04 ~ 0.12	
M 不鏽鋼	30 ~ 80	0.1 ~ 0.2mm	0.01 ~ 0.03	0.01 ~ 0.04	0.01 ~ 0.04	0.01 ~ 0.04	NC5254
K 鑄鐵	80 ~ 180	0.1 ~ 0.5mm	0.02 ~ 0.08	0.03 ~ 0.12	0.05 ~ 0.15	0.05 ~ 0.15	NC2057
N 鋁、非鐵金屬	150 ~ 300	0.2 ~ 1.0mm	0.03 ~ 0.10	0.04 ~ 0.20	0.05 ~ 0.25	0.05 ~ 0.25	XP9000

1

星艦定位鑽

切削資料

SI12 - S9MT1203

工件材質	Vc (m/min)	60°		90°	120°	142°	刀片鍍層
		Q (每刀啄鑽深度)	f (mm/rev.)				
P 低碳鋼 C<0.3% 低合金鋼 C<0.3% 中碳鋼 C>0.3% 高合金鋼 C>0.3%	120 ~ 250	0.1 ~ 0.5mm	0.03 ~ 0.08	0.05 ~ 0.20	0.06 ~ 0.25	0.06 ~ 0.25	NC5254
	100 ~ 220		0.03 ~ 0.07	0.04 ~ 0.15	0.05 ~ 0.20	0.05 ~ 0.20	
	100 ~ 200		0.03 ~ 0.08	0.05 ~ 0.20	0.06 ~ 0.25	0.06 ~ 0.25	NC2057
	80 ~ 180		0.02 ~ 0.06	0.04 ~ 0.12	0.05 ~ 0.16	0.05 ~ 0.16	
M 不鏽鋼	30 ~ 80	0.1 ~ 0.2mm	0.01 ~ 0.03	0.01 ~ 0.04	0.01 ~ 0.04	0.01 ~ 0.04	NC5254
K 鑄鐵	80 ~ 180	0.1 ~ 0.5mm	0.02 ~ 0.08	0.04 ~ 0.15	0.05 ~ 0.20	0.05 ~ 0.20	NC2057
N 鋁、非鐵金屬	150 ~ 300	0.2 ~ 1.0mm	0.03 ~ 0.10	0.05 ~ 0.22	0.06 ~ 0.25	0.06 ~ 0.25	XP9000

SI16 - S9MT1603

工件材質	Vc (m/min)	60°		90°	120°	142°	刀片鍍層
		Q (每刀啄鑽深度)	f (mm/rev.)				
P 低碳鋼 C<0.3% 低合金鋼 C<0.3% 中碳鋼 C>0.3% 高合金鋼 C>0.3%	120 ~ 250	0.1 ~ 0.5mm	0.04 ~ 0.10	0.05 ~ 0.20	0.06 ~ 0.25	0.06 ~ 0.25	NC5254
	100 ~ 220		0.03 ~ 0.08	0.04 ~ 0.15	0.05 ~ 0.20	0.05 ~ 0.20	
	100 ~ 200		0.04 ~ 0.10	0.05 ~ 0.20	0.06 ~ 0.25	0.06 ~ 0.25	NC2057
	80 ~ 180		0.02 ~ 0.07	0.04 ~ 0.12	0.05 ~ 0.16	0.05 ~ 0.16	
M 不鏽鋼	30 ~ 80	0.1 ~ 0.2mm	0.01 ~ 0.03	0.01 ~ 0.04	0.01 ~ 0.04	0.01 ~ 0.04	NC5254
K 鑄鐵	80 ~ 180	0.1 ~ 0.5mm	0.03 ~ 0.08	0.04 ~ 0.15	0.05 ~ 0.20	0.05 ~ 0.20	NC2057
N 鋁、非鐵金屬	150 ~ 300	0.2 ~ 1.0mm	0.04 ~ 0.12	0.05 ~ 0.25	0.06 ~ 0.25	0.06 ~ 0.25	XP9000

SI20 - S9MT2004

工件材質	Vc (m/min)	60°		90°	120°	142°	刀片鍍層
		Q (每刀啄鑽深度)	f (mm/rev.)				
P 低碳鋼 C<0.3% 低合金鋼 C<0.3% 中碳鋼 C>0.3% 高合金鋼 C>0.3%	120 ~ 250	0.1 ~ 0.5mm	0.04 ~ 0.10	0.05 ~ 0.25	0.06 ~ 0.30	0.06 ~ 0.30	NC5254
	100 ~ 220		0.03 ~ 0.08	0.04 ~ 0.20	0.05 ~ 0.25	0.05 ~ 0.25	
	100 ~ 200		0.04 ~ 0.10	0.05 ~ 0.25	0.06 ~ 0.30	0.06 ~ 0.30	NC2057
	80 ~ 180		0.02 ~ 0.07	0.04 ~ 0.15	0.05 ~ 0.20	0.05 ~ 0.20	
M 不鏽鋼	30 ~ 80	0.1 ~ 0.2mm	0.01 ~ 0.03	0.01 ~ 0.04	0.01 ~ 0.04	0.01 ~ 0.04	NC5254
K 鑄鐵	80 ~ 180	0.1 ~ 0.5mm	0.03 ~ 0.08	0.04 ~ 0.20	0.05 ~ 0.25	0.05 ~ 0.25	NC2057
N 鋁、非鐵金屬	150 ~ 300	0.2 ~ 1.0mm	0.04 ~ 0.12	0.05 ~ 0.30	0.06 ~ 0.30	0.06 ~ 0.30	XP9000

1

星艦定位鑽



微型定位鑽 >>>

90° / 120° / 142°

0.1 & 0.2mm

為微型鑽頭在工件上製造完美的導引孔。
不產生靜點，取得最佳中心定位。

P M K N H

▶ 一支刀桿可以裝置全部X060系列刀片



Features >

▶ 每片刀片有2個切削刃口。

- 微型鑽幾何設計目的在優化刀片剛性和精準度，藉以引導微型鑽頭朝孔的中心線方向移動。
- 碳化鎢刀片可以承受很長的刀具壽命。
- 它可以為微型鑽頭進入工件時提供一致的表面，特別是適用於圓形、有角度或彎曲的表面。

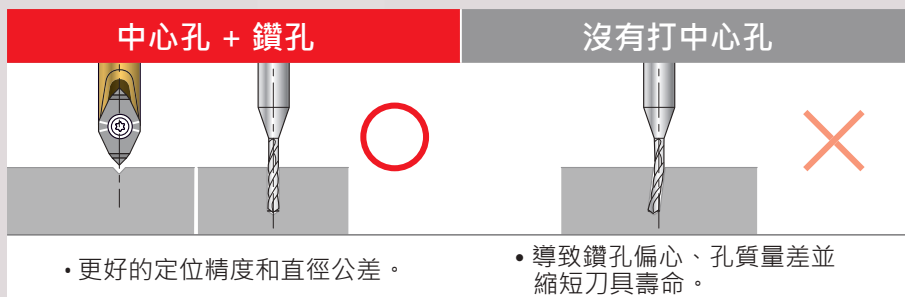

0.1 and 0.2_{mm} 微型定位鑽 90°, 120° & 142°

90°
120°
142°



▶ 刀片 >>

- NC2032:** • 應用於 < HRC40之鋼材 · 合金鋼 · 鑄鐵
- NC2035:** • ALDURA鍍層
• 應用於硬化鋼可達HRC56
- XP9001:** • 應用於非鐵金屬 · 鋁合金 · 銅合金 · 塑膠 · 壓克力

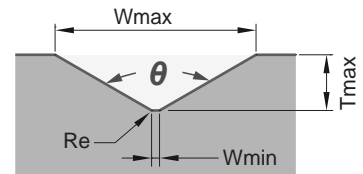

角度	訂購編號	鍍層	材質	Re	尺寸			Wmin.	Wmax.	Tmax.
					L	S	Re			
90°	X060A90W010R	NC2032	TiAlN	K20F	0.02	6	2.05	0.1	1.1	0.5
		NC2035	ALDURA							
		XP9001	Uncoated							
90°	*X060A90W020R	NC2032	TiAlN	K20F	0.04	6	2.05	0.2	2.2	1.0
		NC2035	ALDURA							
		XP9001	Uncoated							
120°	X060A120W010R	NC2032	TiAlN	K20F	0.02	6	2.05	0.1	2.53	0.7
142°	X060A142W010R	NC2032	TiAlN	K20F	0.02	6	2.05	0.1	2.42	0.4

* X060A90W020R 也適合雕刻。

▶ 刀桿 >>

- 一支刀桿可以裝置全部X060系列刀片
- XL (100mm加長型) · 建議使用於鋁合金或軟材雕刻 · 不平衡量 < 0.6gm

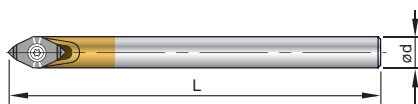

訂購編號	Part No.	材質	Ød	L	螺絲	扳手
99619-X060-06	BC06-CT-X060	鋼	6	40	NS-22044 0.9Nm	NK-T7
99619-X060-06L	BC06-CT-X060-60L	鎢鋼	6	60		
99619-X060-06LS	BC06-CT-X060-60LS	鋼	6	60		
99619-X060-06XL	BC06-CT-X060-100L	鎢鋼	6	100		
99619-X060-08	BC08-CT-X060	鋼	8	60		

▶ 切削資料 >>

工件材質	主軸轉速 (r.p.m)	機台進給 (mm/rev.)			刀片鍍層
		X060A90W010R	X060A90W020R	X060A120W010R X060A142W010R	
低碳鋼 C<0.3%	8000 ~ 40000	0.002 ~ 0.012	0.002 ~ 0.015	0.002 ~ 0.015	NC2032
中碳鋼 C>0.3%		0.002 ~ 0.010	0.002 ~ 0.012	0.002 ~ 0.012	NC2032
合金鋼		0.002 ~ 0.010	0.002 ~ 0.010	0.002 ~ 0.010	NC2032, NC2035
不鏽鋼		0.002 ~ 0.008	0.002 ~ 0.010	0.002 ~ 0.010	NC2032
鑄鐵		0.002 ~ 0.010	0.002 ~ 0.010	0.002 ~ 0.010	NC2032
鋁、非鐵金屬		0.002 ~ 0.015	0.002 ~ 0.020	-	XP9001
熱處理 HRC56度		0.002 ~ 0.006	0.002 ~ 0.006	-	NC2035



NC 車銑萬用鑽 >>>

No Need To Choose, Nine9 Does It All!

採用捨棄式刀片
高效率、壽命長、節省成本

P M K N S H

- ▶ 一支刀桿可裝置多種刀片
- ▶ 一支刀桿可多功能應用



Features >>>

- ▶ 單刃式加工 · 孔定位超精準
- ▶ 各式夾持柄徑 - $\varnothing 5, \varnothing 6, \varnothing 8, \varnothing 10, \varnothing 12, \varnothing 16, \varnothing 20, \varnothing 25\text{mm}, \varnothing 3/8", \varnothing 1/2", \varnothing 5/8", \varnothing 1/4", \varnothing 3/4", \varnothing 1", M5, M6$ 和 $M8$.
- ▶ $60^\circ / 82^\circ / 90^\circ / 100^\circ / 142^\circ / 145^\circ$ 各種角度刀片
 - 適合中心孔、倒角、銑槽及雕刻
 - 刀片有2刃口和4刃口可供選擇
 - 高切削速度



Applications

- 在加工中心機上進行輪廓倒角

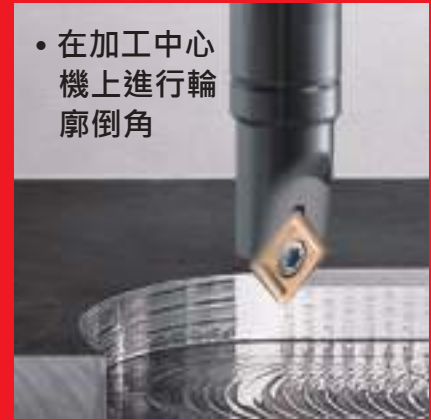

2

▼ CNC 車床



◀ 切削中心機 ▶



- 雕刻
- 銑槽
- 中心孔
- 倒角

“ 多功能刀具，適合中心孔、倒角、銑槽及雕刻。 ”

中心孔

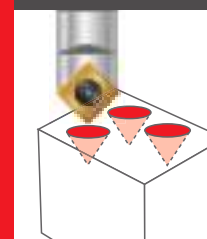

倒角

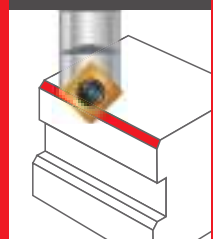

銑槽

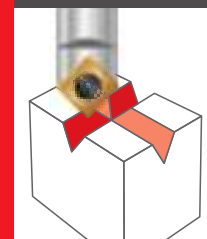

雕刻

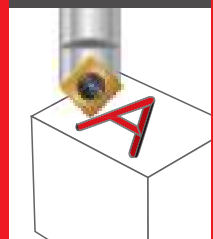

雙角度中心孔

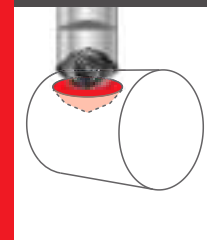

車端面

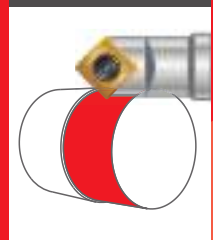

創新的車鑽思維!

▶ 0.5XD 中心孔 >>

使用車銑萬用鑽有許多加工優勢，
是製造商與供應商加工的最佳選擇。

▶ 車銑萬用鑽優勢 >>

- 高進給率：導引鑽強化切削刃。
- 最佳中心定位：單刃加工與搪孔加工精度相似。
- 增加壽命。

2

NC車銑萬用鑽

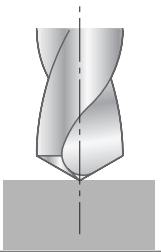
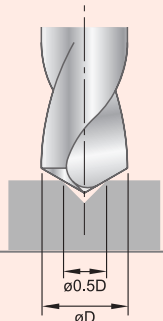
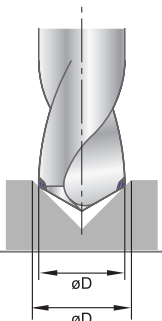
NC車銑萬用鑽	無中心孔	0.5xD 中心孔	較大中心孔
<ul style="list-style-type: none"> • 最佳中心定位! • 壽命長! 	<ul style="list-style-type: none"> • 鑽頭缺少定位精準度與直徑公差 	<ul style="list-style-type: none"> • 最佳效能 • 高轉速 · 高進給率 • 最佳定位精準度及直徑公差。 	<ul style="list-style-type: none"> • 延伸中心孔加工時間! • 較無導引作用 • 壽命短
			
	<p>刀具壽命不穩定</p> <p>×</p>	<p>○</p>	<p>×</p>

▶ NC車銑萬用鑽多種應用 >>

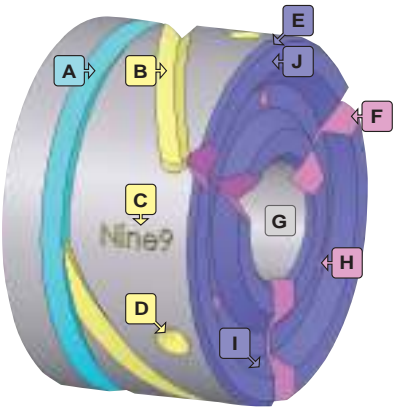
車銑中心機	圖示	應用程序	多功能切削工具
	A	車槽	使用於 CNC 車床 CNC 車銑中心機 加工中心機 銑床 SPM machines ...
	B	銑螺旋槽	
	C	雕刻	
	D	中心鑽	
	E	車倒角	
	F	端面銑槽	
	G	車內孔	
	H	端面中心孔	
	I	內倒角	
	J	面槽	

V9MT0802 / V9MT12T3

60°

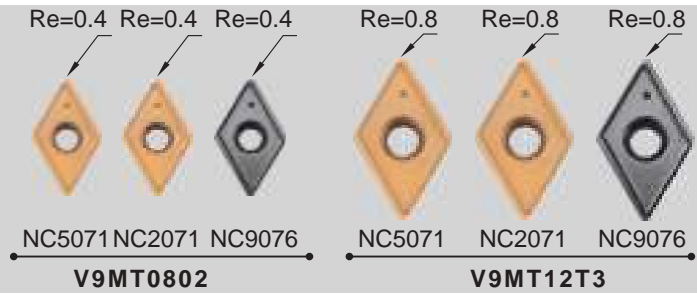
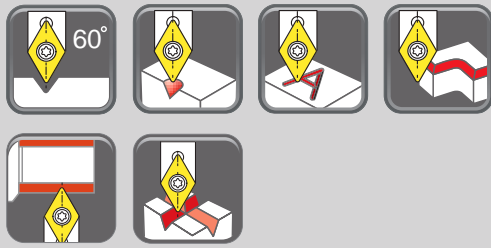

▶ 刀片 >>

- 60度中心孔，最大直徑可達13mm
- 銑槽效率高

NC5071: • 適用高合金鋼與鑄鐵
• 刃口強化，高速加工
• 刀片有2個切削刃口

NC2071: • 泛用材種，碳鋼、低合金鋼、不鏽鋼、鑄鐵、非鐵金屬及鈦合金
• 刀片有2個切削刃口

NC9076: • 適用非鐵金屬，鋁合金，鈦合金，銅合金，長切屑軟金屬
• 優異的加工表面
• 刀片有2個切削刃口

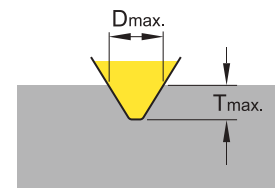

訂購編號	鍍層	材質	尺寸	Dmax.	Tmax.			
						L	S	Re
V9MT0802CT	NC5071	TiAlN & TiN		9	7.3			
	NC2071	TiN				8	2.38	0.4
	NC9076	DLC						
V9MT12T3CT	NC5071	TiAlN & TiN		13	10.3			
	NC2071	TiN				12.7	3.97	0.8
	NC9076	DLC						
V9MT12T312CT (車槽端面切槽用)	NC2071	TiN		12.7	3.97	1.2	13	10.3

▶ 刀桿 >>

- 單刃切削，孔定位超精準
- 適用於銑床，車床，切削中心機

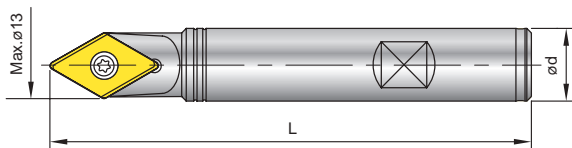

訂購編號	Part No.	Ød	L	刀片類型	螺絲	扳手
99616-09V	BC08-CT-09V	8	60	V9MT08	NS-25045 0.9 Nm	NK-T7
99616-13V	SB16-CT-13V	16	100	V9MT12	NS-35080 2.5 Nm	NK-T15
99616-13V-5/8	SB5/8"-CT-13V	5/8"	100			

2
NC車銑萬用鑽

82° V0820802 / V08212T3

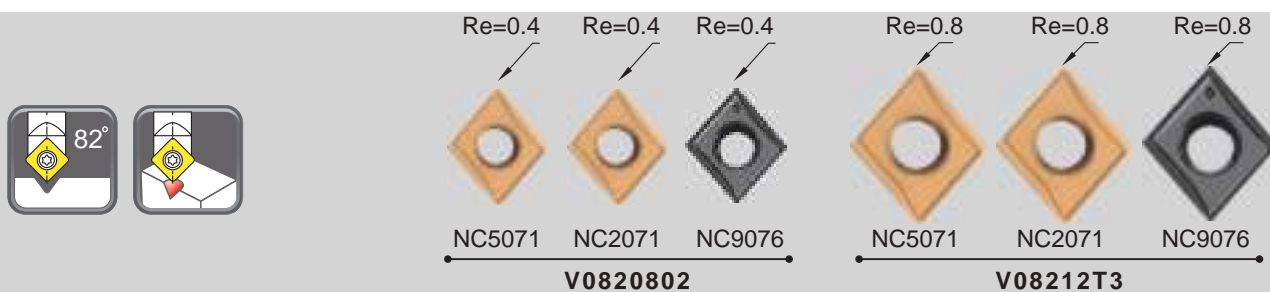

▶ 刀片 >>

- 82度中心孔，最大直徑可達14mm
- 符合美式皿頭螺絲孔
- 適合高速加工

- NC5071:**
- 適用高合金鋼與鑄鐵
 - 刃口強化，高速加工
 - 刀片有2個切削刃口

- NC2071:**
- 泛用材種，碳鋼、低合金鋼、不鏽鋼、鑄鐵、非鐵金屬及鈦合金
 - 刀片有2個切削刃口

- NC9076:**
- 適用非鐵金屬，鋁合金，鈦合金，銅合金，長切屑軟金屬
 - 優異的加工表面
 - 刀片有2個切削刃口

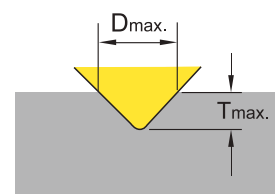

訂購編號	鍍層	材質	尺寸	Dmax.	Tmax.
V0820802	NC5071	TiAlN & TiN		9 (0.354")	4.8 (0.189")
	NC2071	TiN			
	NC9076	DLC			
V08212T3	NC5071	TiAlN & TiN	12.7 3.97	14 (0.551")	7.5 (0.295")
	NC2071	TiN			
	NC9076	DLC			

▶ 刀桿 >>

- 單刃切削，孔定位超精準
- 適用於銑床，車床，切削中心機

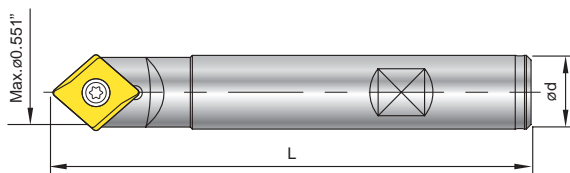

訂購編號	Part No.	Ød	L	刀片類型	螺絲	扳手
99619-V082-3/8	SB3/8"-CT-V082	3/8"	90	V0820802	NS-30055 2.0 Nm	NK-T8
99619-V082-5/8	SB5/8"-CT-V082	5/8"	100	V08212T3	NS-35080 2.5 Nm	NK-T15

2

NC車銑萬用鑽

N9MT05T1 / N9MT0602

90°

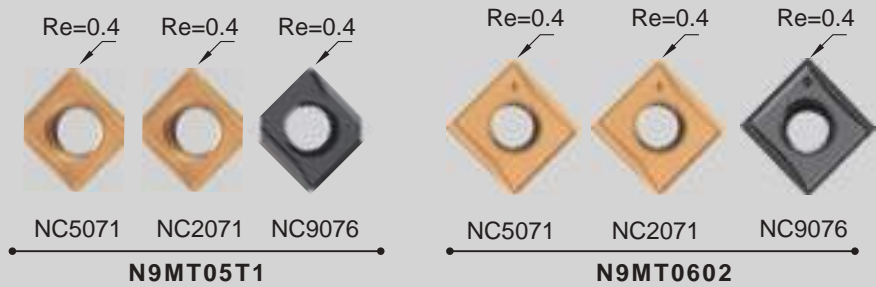
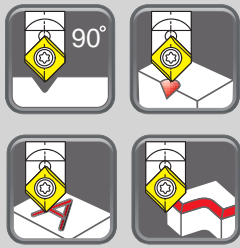

▶ 刀片 >>

- 迷你中心定位鑽，低切削阻抗
- 適用於瑞士型自動車床

- NC5071:**
- 適用高合金鋼與鑄鐵
 - 刃口強化，高速加工
 - 刀片有2個切削刃口

- NC2071:**
- 泛用材種，碳鋼、低合金鋼、不鏽鋼、鑄鐵、非鐵金屬及鈦合金
 - 刀片有2個切削刃口

- NC9076:**
- 適用非鐵金屬，鋁合金，鈦合金，銅合金，長切屑軟金屬
 - 優異的加工表面
 - 刀片有2個切削刃口

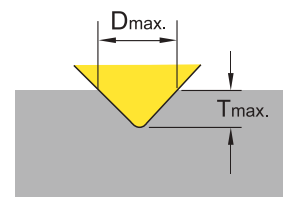

訂購編號	鍍層	材質	尺寸	Dmax.	Tmax.
N9MT05T1CT	NC5071	TiAlN & TiN		6	2.8
	NC2071	TiN			
	NC9076	DLC			
N9MT0602CT	NC5071	TiAlN & TiN	6.35	8	3.8
	NC2071	TiN			
	NC9076	DLC			

▶ 刀桿 >>

- 最小尺寸的捨棄式中心鑽
- 單刃切削，孔定位超精準
- 適用於銑床，車床，切削中心機

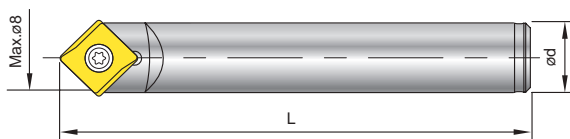

訂購編號	Part No.	Ød	L	刀片類型	螺絲	扳手
99616-06-5	BC05-CT-06	5	35	N9MT05	NS-20036 0.6 Nm	NK-T6
99616-06-6	BC06-CT-06	6	35			
99616-06-6L	BC06-CT-06-60L	6	60			
99616-08-8	BC08-CT-08	8	60	N9MT06	NS-22044 0.9 Nm	NK-T7

注意: 99616-06-6L為鎢鋼柄。

2

NC車銑萬用鑽

90° N9MT0802 / N9MT1003

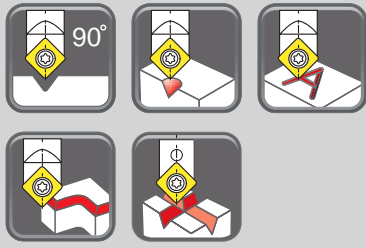

▶ 刀片 >>

- NC40:**
 - 泛用材種，適合鋼鐵
 - 刀片有4個切削刃口
- NC10:**
 - 高正角切削刃口，適用非鐵金屬，鑄鐵，不鏽鋼
 - 刀片有4個切削刃口
- H-NC5071:**
 - 適用高合金鋼與鑄鐵。刃口強化，高速加工
 - 刀片有2個切削刃口
- H-NC40:**
 - 最適合打中心孔，泛用材種，適合鋼鐵，鑄鐵
 - 刀片有2個切削刃口
- H-NC9076:**
 - 高正角切削刃口
 - 適用非鐵金屬，鋁合金，鈦合金，銅合金，長切屑軟金屬
 - 刀片有2個切削刃口
- H-NC2071:**
 - 高正角切削。泛用材種，適合鋼鐵，鑄鐵
 - 刀片有2個切削刃口

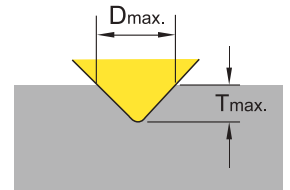

訂購編號	鍍層	材質	尺寸			Dmax.	Tmax.
			L	S	Re		
N9MT080208CT	NC40	TiN	8.31	2.38	0.8	10	4.5
N9MT080204CT	NC40	TiN	8.31	2.38	0.4		
	NC10	TiAlN	8.31	2.38	0.4		
	H-NC5071	TiAlN & TiN	8.31	2.38	0.8		
N9MT0802CT2T	H-NC40	TiN	8.31	2.38	0.8	12.6	5.7
	H-NC9076	DLC	10	3.18	1.2		
N9MT1003CT2T	H-NC2071	TiN	10	3.18	1.2		

▶ 刀桿 >>

- 單刃切削，孔定位超精準
- 適用於銑床，車床，切削中心機

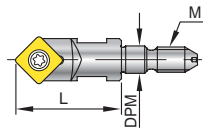
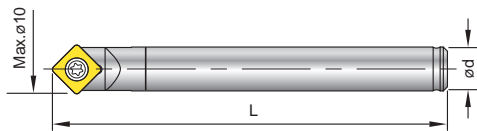

Ø10, Ø3/8", Ø12



99616-10-SL10

訂購編號	Part No.	Ød	L	M	DPM	刀片類型	螺絲	扳手
99616-10	BC10-CT-10	10	90	-	-	N9MT0802	NS-30055 2.0 Nm	NK-T8
99616-10-SL10	SL10-CT-10	10	90	-	-			
99616-10-3/8	BC3/8"-CT-10	3/8"	90	-	-			
99616-10-M5	M5-CT-10	M5	25	M5xP0.8	5.5			
99616-10-M6	M6-CT-10	M6	25	M6xP1.0	6.5			
99616-10-150L	BC10-CT-10-150L	10	150	-	-			
99616-12	BC12-CT-13	12	90	-	-	N9MT1003	NS-30072 2.0 Nm	NK-T9

注意: • 99616-10-SL10 搭配平側桿。
• Nine9 M5, M6螺牙適用延長桿，詳見9-189頁。

2

NC車銑萬用鑽

N9MT11T3

90°

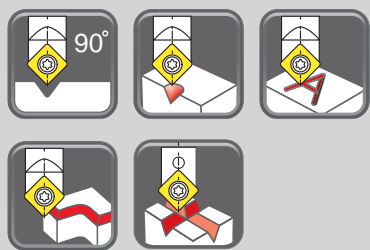

▶ 刀片 >>

- NC40:**
 - 泛用材種，適合鋼鐵
 - 刀片有4個切削刃口
- NC10:**
 - 高正角切削刃口，適用非鐵金屬，鑄鐵，不鏽鋼
 - 刀片有4個切削刃口
- NC60:**
 - 加工鋼材硬度可達HRC56度
 - 刀片有4個切削刃口
- H-NC5071:**
 - 適用高合金鋼與鑄鐵。刃口強化，高速加工
 - 刀片有2個切削刃口
- H-NC40:**
 - 最適合打中心孔，泛用材種，適合鋼鐵，鑄鐵
 - 刀片有2個切削刃口
- H-NC9076:**
 - 高正角切削刃口。優異的加工表面
 - 適用非鐵金屬，鋁合金，鈦合金，銅合金，長切屑軟金屬
 - 刀片有2個切削刃口

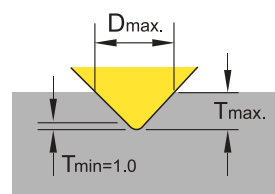

NC40 / Wiper design / NC60

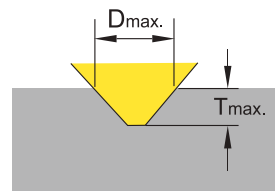

Other grade

訂購編號	鍍層	材質	Re	尺寸		Dmax.	Tmax.
				L	S		
N9MT11T3CT	NC40	TiN	P35	11.11	3.97	14	7
	NC10	TiAlN	K10F				
	NC60	CERMET					
N9MT11T3CT2T	H-NC5071	TiAlN & TiN	K20F				
	H-NC40	TiN	K20F				
	H-NC9076	DLC	K20F				

▶ 刀桿 >>

- 單刃切削，孔定位超精準
- 適用於銑床，車床，切削中心機

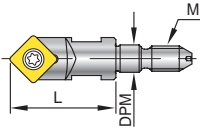
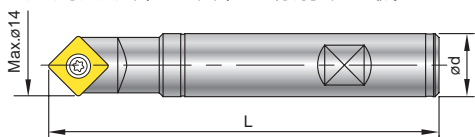

訂購編號	Part No.	Ød	L	M	DPM	螺絲	扳手
99616-14-10	SB10-CT-15	10	79	-	-		
99616-14-12	SB12-CT-15	12	99	-	-		
99616-14-1/2	SB1/2"-CT-15	1/2"	99	-	-		
99616-14-5/8	SB5/8"-CT-15	5/8"	99	-	-		
99616-14	SB16-CT-15	16	99	-	-		
99616-14-150L	SB16-CT-15-150L	16	150	-	-		
99616-14--20-150L	SB20-CT-15-150L	20	150	-	-		
99616-14-220L	SB20-CT-15-220L	20	220	-	-		
99616-14-M8	M8-CT-15	-	30	M8xP1.25	8.5		
99616-14-PR	SB16-CT-15PR (僅適用N9MT11T3CT-2T-H刀片)	16	99	-	-		



注意：• 接桿請用99801，詳見9-189頁。

2

NC車銑萬用鑽

90° N9MT1704

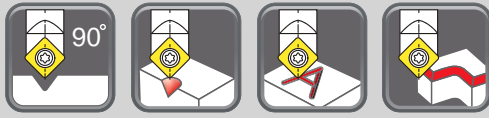

▶ 刀片 >>

• 90度中心孔，最大直徑可達22mm

NC5071: • 適用高合金鋼與鑄鐵
• 刃口強化，高速加工
• 刀片有2個切削刃口

NC2071: • 高正角切削
• 泛用材種，適合鋼鐵，鑄鐵
• 刀片有2個切削刃口

NC9036: • 適用非鐵金屬，鋁合金，鈦合金，銅合金，長切屑軟金屬，不鏽鋼
• 高正角切削，表面優異
• 刀片有2個切削刃口

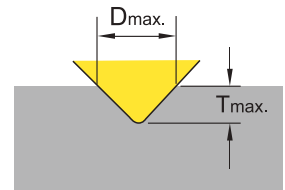

訂購編號	鍍層	材質	尺寸	Dmax.	Tmax.
N9MT1704CT	NC5071	TiAlN & TiN		22	10.4
	NC2071	TiN			
	NC9036	DLC			

▶ 刀桿 >>

• 單刃切削，孔定位超精準
• 適用於銑床，車床，切削中心機

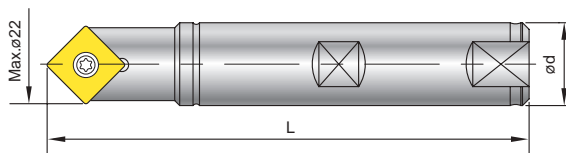

訂購編號	Part No.	Ød	L	螺絲	扳手
99616-22	SB20-CT-22-100L	20	100		
99616-22-25	SB25-CT-22-150L	25	150	NS-50125 5.5 Nm	NK-T20
99616-22-1	SB1"-CT-22	1"	150		

2

NC車銑萬用鑽

N9MT2204 / N9MT2506

90°



NC40

▶ N9MT2204CT >>

- NC40:**
- 泛用材種 · 適合鋼鐵 · 鑄鐵
 - 刀片有3個切削刃口

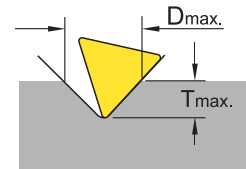

訂購編號	鍍層	材質	尺寸	尺寸		Dmax.	Tmax.
				L	S		
N9MT2204CT-NC40	TiN	P35		20.83	4.76	25	12.2

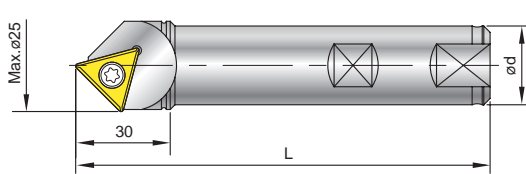

訂購編號	Part No.	Ød	L	螺絲	扳手
99616-25-CT28	SB25-CT-28	25	120	NS-40100 3.5 Nm	NK-T15
99616-1-CT28	SB25.4-CT-28	1"	120		

▶ N9MT2506 >>

- NC2033:**
- 適合鋼鐵 · 鑄鐵
 - 刀片有2個切削刃口
- XP9000:**
- 適用非鐵金屬 · 鋁合金 · 銅合金 · 塑膠 · 壓克力等軟性材料
 - 刀片有2個切削刃口

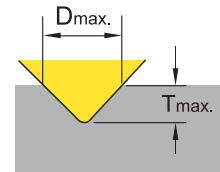

訂購編號	鍍層	材質	尺寸	尺寸			Dmax.	Tmax.	
				L	S	Re			
N9MT2506CT	NC2033 XP9000	TiAlN -	K20F		25	6.35	1.2	32	15.4

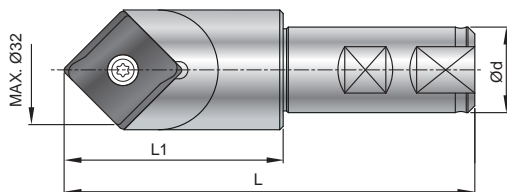

訂購編號	Ød	L	L1	螺絲	扳手
99616-32-25	25	120	64	NS-60180 5.5 Nm	NK-UT25
99616-32-1	1"				

2

NC車銑萬用鑽

100° 120° 142° N9MT11T3CT2T-H

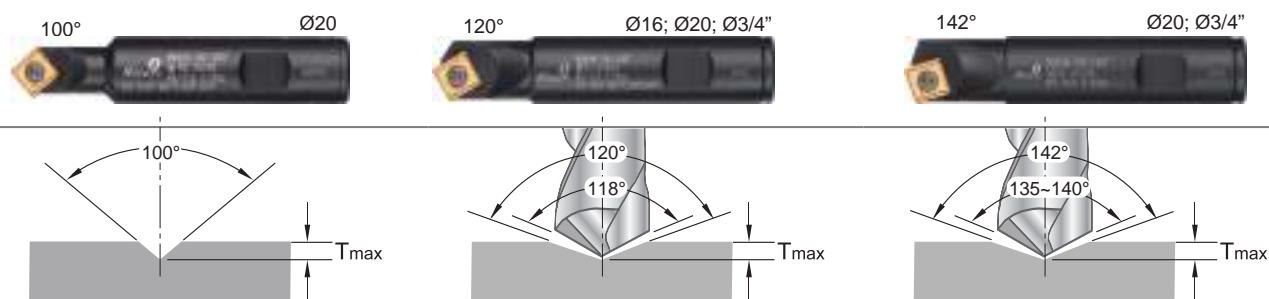

• 適用於 100° 規格螺絲孔。

• 鑽頭頂角 118° 之定位孔。
• 60° 倒角。

• 鑽頭頂角 135°~140° 之定位孔。

2

NC車銑萬用鑽

▶ 刀片 >>

H-NC5071: • 適用高合金鋼與鑄鐵。刃口強化，高速加工
• 刀片有2個切削刃口

H-NC40: • 泛用材種，適合鋼鐵，鑄鐵
• 刀片有2個切削刃口

H-NC9076: • 高正角切削刃口
• 適用非鐵金屬，鋁合金，鈦合金，銅合金，長切屑軟金屬
• 優異的加工表面
• 刀片有2個切削刃口



訂購編號	鍍層	材質	Re	尺寸		
				L	S	Re
N9MT11T3CT2T	H-NC5071	TiAlN & TiN		11	3.97	0.8
	H-NC40	TiN				
	H-NC9076	DLC				

▶ 刀桿 >>

- 可加工100°/120°/142°中心孔
- 單刃切削，孔定位超精準
- 使用中心孔定位功能，大幅提昇鑽頭壽命

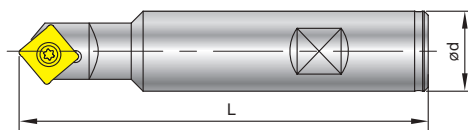

訂購編號	Part No.	角度	Ød	L	螺絲 / 扳手	Dmax.	Tmax.
99616-20-100	SB20-CT-16-100	100°	20	100		16	6.3
99616-16-120	SB16-CT-16-120	120°	16	100	NS-35080 2.5 Nm	17	4.76
99616-20-120	SB20-CT-16-120	120°	20	100		17	4.76
99616-3/4-120	SB3/4"-CT-16-120	120°	3/4"	100	NK-T15	17	4.76
99616-20-142	SB20-CT-16-142	142°	20	100		18.5	3.16
99616-3/4-142	SB3/4"-CT-16-142	142°	3/4"	100		18.5	3.16

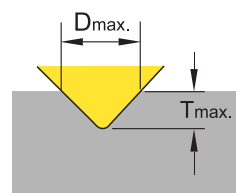

V14208 / V14216

142°

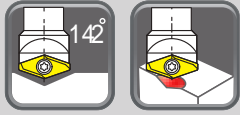

V1420803-NC2071

V1421604-NC2071

▶ 刀片 >>

- 可以提供鑽頂角135° - 140°，高效率鑽頭的前置定位功能
- 142度中心孔，最大直徑可達32mm

- NC2071:**
- 高正角切削刃口
 - 泛用材種，適合鋼鐵，鑄鐵
 - 刀片有2個切削刃口

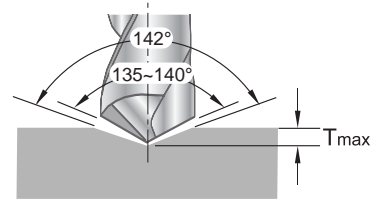

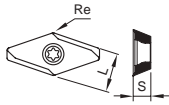
訂購編號	鍍層	材質	尺寸	Dmax.	Tmax.
V1420803-NC2071	TiN	K20F		16	2.8
V1421604-NC2071			32	5.5	

2

NC車銑萬用鑽

▶ 刀桿 >>

- 使用中心孔定位功能，可提昇鑽頭壽命
- 提昇鑽頭壽命，可以降低鑽頭成本
- 單刃切削，孔定位超精準

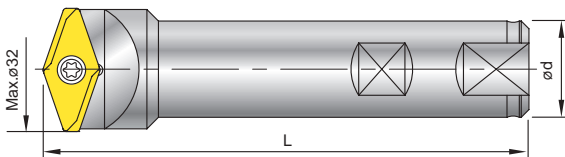

訂購編號	Part No.	Ød	L	刀片類型	螺絲	扳手
99619-V142-16	SB16-CT-V142-16	16	100	V1420803	 NS-30072 2.0 Nm	 NK-T9
99619-V142-32	SB25-CT-V142-32	25	120	V1421604	 NS-50125 5.5 Nm	 NK-T20

145° +90° WSP Spotting



NC2033

▶ 結合中心孔和倒角功能145°+90° >>

- 中心孔和倒角，一次完成，節省時間
- 高效率鑽頭的前置定位功能
- 圓弧表面加工，效果優異

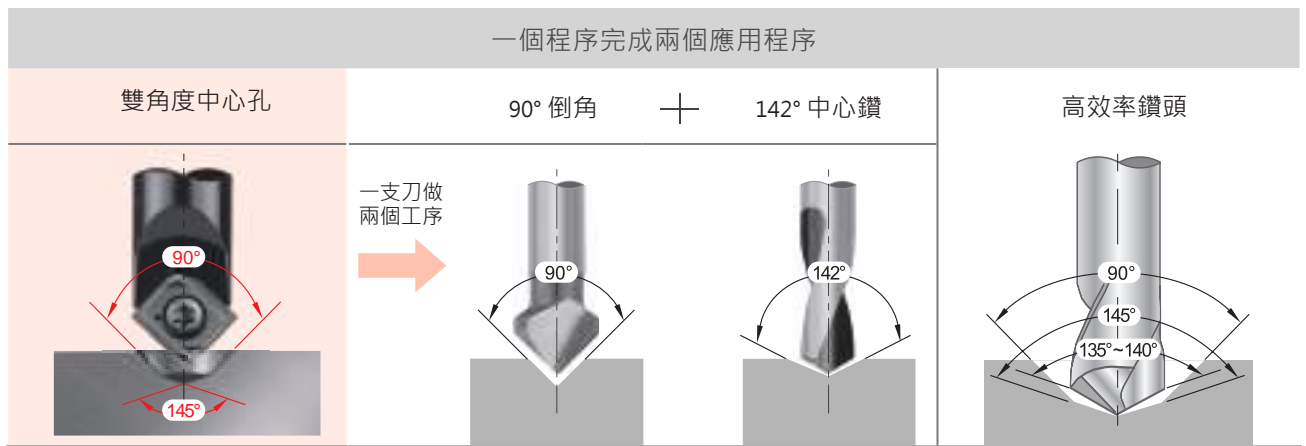

▶ 刀片 >>

- NC2033:
- 刀片切削刃口研磨
 - 泛用材種，適合鋼鐵，鑄鐵
 - 刀片有2個切削刃口

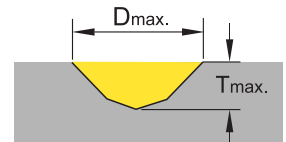

訂購編號	鍍層	材質	M	*D1±0.05	D2	L2	Dmax.	Tmax.
N9MT0802M04C-NC2033	TiAlN	K20F	M4x0.7	3.30	4.20	0.93	8	2.83
N9MT0802M05C-NC2033			M5x0.8	4.20	5.25	1.14		2.52
N9MT0802M06C-NC2033			M6x1.0	5.00	6.30	1.39		2.24
N9MT11T3M08C-NC2033	TiAlN	K20F	M8x1.25	6.80	8.40	1.81	13	4.11
N9MT11T3M10C-NC2033			M10x1.5	8.50	10.50	2.28		3.53
N9MT11T3UNC25-NC2033	TiAlN	K20F	1/4-20 UNC	5.08	6.70	1.55	13	4.70
N9MT11T3UNC31-NC2033			5/16-18 UNC	6.53	8.40	1.90		4.20
N9MT11T3UNC38-NC2033			3/8-16 UNC	7.94	10.00	2.22		3.72
N9MT1704M12C-NC2033	TiAlN	K20F	M12x1.75	10.25	12.60	2.91	20	6.61
N9MT1704M14C-NC2033			M14x2.0	12.00	14.70	3.22		5.87
N9MT1704M16C-NC2033			M16x2.0	14.00	16.80	3.51		5.11

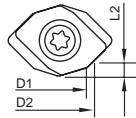

注意: * D1 請參閱鑽鑽尺寸。
* 技術資料請參考2-46頁。

2

NC車銑萬用鑽

WSP Spotting



▶ 刀桿 >>

- 使用標準型車銑萬用鑽刀桿
- 中心孔和倒角，一次完成

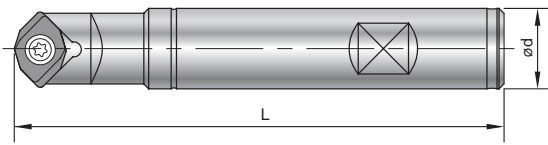

訂購編號	Part No.	Ød	L	刀片類型	M	螺絲	扳手
99616-10	BC10-CT-10	10	89.08±0.29	N9MT0802	M4~M6	NS-30055 2.0Nm	NK-T8
99616-10-3/8	BC3/8"-CT-10	3/8"					
99616-14	SB16-CT-15	16	97.55±0.55	N9MT11T3	M8~M10 1/4~3/8 UNC	NS-35080 2.5Nm	NK-T15
99616-14-5/8	SB5/8"-CT-15	5/8"					
99616-22	SB20-CT-22-100L	20	96.24±0.64	N9MT1704	M12~M16	NS-50125 5.5Nm	NK-T20
99616-22-3/4	SB3/4"-CT-22	3/4"	96.24±0.64				
99616-22-1	SB1"-CT-22	1"	146.24±0.64				
99616-22-25	SB25-CT-22-150L	25					

* 其他尺寸刀桿請參照 2-28、2-29 & 2-30 頁

▶ 範例 >>

- 倒角建議值為螺紋公稱尺寸加5%，
例如M6螺絲孔倒角尺寸為直徑6.3mm
- 如果需要更大的倒角，只要鑽孔深度加深即可

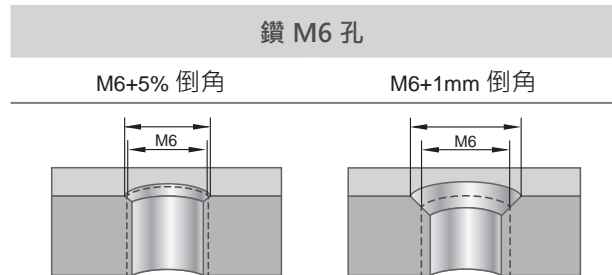

▶ 比較 >>

鎢鋼階級鑽	中心鑽+鑽頭	WSP中心鑽+鑽頭
<ul style="list-style-type: none"> • 成本高 • 壽命短 • 圓弧面加工有問題 	<ul style="list-style-type: none"> • 加工時間長 • 鑽頭易崩損 • 刀具壽命短 	<ul style="list-style-type: none"> • 加工時間短 • 中心定位穩定 • 刀具壽命長 • 同作中心孔及倒角加工

2

NC車銑萬用鑽



圓弧倒角刀 >>>

RC 系列 / 刀片半徑 0.5 ~ 10mm

加工表面優異 · 圓弧曲線順暢

P M K N S

▶ 不同圓弧刀片 · 可共用相同刀桿



Features >

- ▶ 每片刀片有 2 個切削刃口。
 - 鎢鋼圓弧倒角刀片 · 加工壽命長
 - 同一刀片可作圓弧倒角和45°倒角
 - 高切削速度 · 進給率快
 - 圓弧偏移值小
 - 使用標準刀桿 99616-06, 99616-14, 99616-22 & 99616-32.

▶ 應用

- a** 刀片半徑 0.5
- b** 刀片半徑 1.0
- c** 刀片半徑 2.0

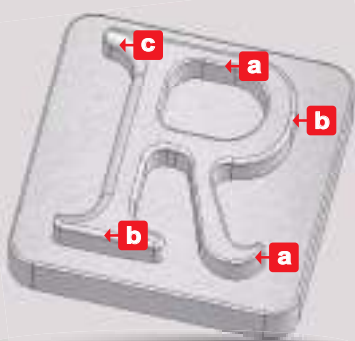

2

NC車銑萬用鑽

N9MT05T1RC



RC0.5~RC1.0
可替換於同款刀桿。



RC



NC2071



NC9036

▶ 刀片 >>

- 不同圓弧刀片，可共用相同刀桿
- 圓弧R0.5中心偏移值1.25mm

NC2071:

- 泛用材種，適合鋼鐵，鑄鐵
- 刀片圓弧研磨位置精準
- 刀片有2個切削刃口。

NC9036:

- 適用非鐵金屬，鋁合金，鈦合金，銅合金，長切屑軟金屬，不鏽鋼
- 高正角切削，表面優異
- 刀片有2個切削刃口

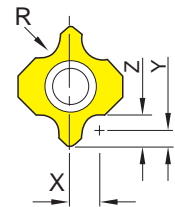

2

圓弧倒角刀

刀片半徑	訂購編號	鍍層	材質	偏擺值			尺寸			
				X	Y	Z				
0.5	N9MT05T1RC05	NC2071	TiN	K20F	1.25	0.75	1.25		5	1.8
		NC9036	DLC							
0.75	N9MT05T1RC075	NC2071	TiN	K20F	1.50	0.75	1.50			
		NC9036	DLC							
1.0	N9MT05T1RC10	NC2071	TiN	K20F	1.75	0.75	1.75			
		NC9036	DLC							

▶ 刀桿 >>

- 使用車銑萬用鑽標準刀桿

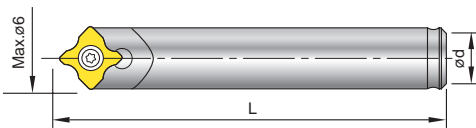

訂購編號	Part No.	Ød	L	螺絲	扳手
99616-06-5	BC05-CT-06	5	35		
99616-06-6	BC06-CT-06	6	35	NS-20036 0.6 Nm	NK-T6
99616-06-6L	BC06-CT-06-60L	6	60		

* 99616-06-6L 為鑄鋼柄

RC N9MT11T3RC



RC1.0~RC3.0
可替換於同款刀桿。



NC40



NC9036

▶ 刀片 >>

- 高切削速度，進給率快
- 同一刀片可作圓弧倒角和45°倒角
- 不同圓弧刀片，可共用相同刀桿

NC40:

- 泛用材種，適合鋼鐵，鑄鐵
- 刀片圓弧研磨位置精準
- 刀片有2個切削刃口

NC9036:

- 適用非鐵金屬，鋁合金，鈦合金，銅合金，長切屑軟金屬，不鏽鋼
- 高正角切削，表面優異
- 刀片有2個切削刃口

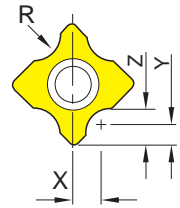

* 以下刀片不可使用99616-14-PR 刀桿

刀片半徑	訂購編號	鍍層	材質	偏擺值			尺寸	
				X	Y	Z	L	S
1.0	N9MT11T3RC10	NC40	TiN	2.75	1.5	2.5	11.11	3.97
		NC9036	DLC					
1.5	N9MT11T3RC15	NC40	TiN	3.25	1.5	3		
		NC9036	DLC					
2.0	N9MT11T3RC20	NC40	TiN	3.75	1.5	3.5		
		NC9036	DLC					
2.5	N9MT11T3RC25	NC40	TiN	4.25	1.5	4		
		NC9036	DLC					
3.0	N9MT11T3RC30	NC40	TiN	4.75	1.4	4.4		
		NC9036	DLC					
1/64	N9MT11T3RC1/64	NC40	TiN	0.086"	0.059"	0.0747"	11.11	3.97
		NC9036	DLC					
1/32	N9MT11T3RC1/32	NC40	TiN	0.101"	0.059"	0.090"		
		NC9036	DLC					
1/16	N9MT11T3RC1/16	NC40	TiN	0.133"	0.059"	0.122"		
		NC9036	DLC					
3/32	N9MT11T3RC3/32	NC40	TiN	0.164"	0.059"	0.153"		
		NC9036	DLC					
1/8	N9MT11T3RC 1/8	NC40	TiN	0.199"	0.055"	0.180"		
		NC9036	DLC					

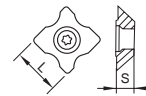

▶ 刀桿 >>

- 使用車銑萬用鑽標準刀桿

訂購編號	Part No.	Ød	L	螺絲/扳手
99616-14-12	SB12-CT-15	12	99	NS-35080 2.5 Nm
99616-14	SB16-CT-15	16		
99616-14-1/2	SB1/2"-CT-15	1/2"	99	NK-T15
99616-14-5/8	SB5/8"-CT-15	5/8"		

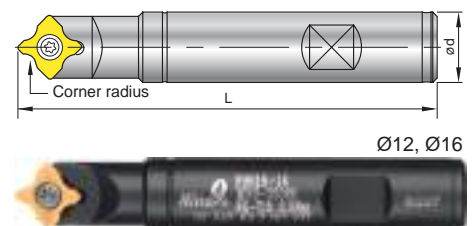

* 其他尺寸刀桿請參照 2-29頁

2

圓弧倒角刀

N9MT1704RC / N9MT2506RC

RC



**RC4.0~RC6.0 /
RC7.0~RC10.0**
可替換於同款刀桿。



NC2071



NC9036

► N9MT1704RC >>

NC2071: • 泛用材種，適合鋼鐵，鑄鐵。刀片有2個切削刃口

NC9036: • 適用非鐵金屬，鋁合金，鈦合金，銅合金，長切屑軟金屬，不鏽鋼。刀片有2個切削刃口

刀片 半徑(R)	訂購編號	鍍層	材質	偏擺值			尺寸 L S
				X	Y	Z	
4.0	N9MT1704RC40	NC2071	TiN	6.15	2	6	
		NC9036	DLC				
5.0	N9MT1704RC50	NC2071	TiN	7.1	2	7	
		NC9036	DLC				
6.0	N9MT1704RC60	NC2071	TiN	8.1	2	8	
		NC9036	DLC				
3/16	N9MT1704RC3/16	NC2071	TiN	0.270"	0.078"	0.268"	
		NC9036	DLC				K20F
1/4	N9MT1704RC1/4	NC2071	TiN	0.333"	0.078"	0.330"	
		NC9036	DLC				K20F

2

圓弧倒角刀

► N9MT2506RC >>

NC2033: • 適合鋼鐵，鑄鐵。刀片有2個切削刃口

XP9000: • 適用非鐵金屬，鋁合金，銅合金，塑膠、壓克力等軟性材料。刀片有2個切削刃口

刀片 半徑(R)	訂購編號	鍍層	材質	偏擺值			尺寸 L S
				X	Y	Z	
7.0	N9MT2506RC70	NC2033	TiAlN	9.5	3	10	
		XP9000	-				
8.0	N9MT2506RC80	NC2033	TiAlN	10.5	3	11	
		XP9000	-				
9.0	N9MT2506RC90	NC2033	TiAlN	11.5	3	12	
		XP9000	-				
10.0	N9MT2506RC100	NC2033	TiAlN	12.5	3	13	
		XP9000	-				K20F
5/16	N9MT2506RC5/16	NC2033	TiAlN	0.411"	0.118"	0.430"	
		XP9000	-				K20F
3/8	N9MT2506RC3/8	NC2033	TiAlN	0.474"	0.118"	0.493"	
		XP9000	-				K20F

► Holder >>

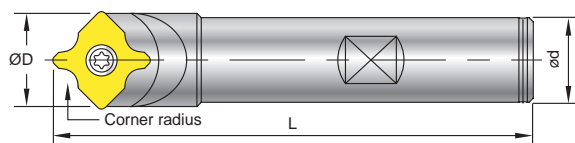

99616-32-XX

訂購編號	Part No.	Ød	L	ØD	刀片類型	螺絲	扳手
99616-22	SB20-CT-22-100L	20	100	23.25	N9MT1704	NS-50125 5.5 Nm	NK-T20
99616-22-25	SB25-CT-22-150L	25	150	23.25			
99616-22-1"	SB1"-CT-22	1"	150	23.25			
99616-32-25	SB25-CT-32-120L	25	120	32.56	N9MT2506	NS-60180 5.5 Nm	NK-UT25
99616-32-1	SB1"-CT-32-120L	1"	120	32.56			



圓弧倒角刀 >>>

R 系列 / 刀片半徑 0.5 ~ 10mm

加工表面優異 · 圓弧曲線順暢

P K

- ▶ 適用於正反45°倒角 (LA系列 刀片), 以及圓弧倒角 (R系列 刀片)

圓弧倒角刀



Features >

▶ 每片刀片有 4 個切削刃口。

- 鎢鋼圓弧倒角刀片 · 加工壽命長
- R1.0 ~ R3.0可裝置在同一刀桿
- 適用正反倒角
- 圓弧偏心值可在加工前設定
- 刀片圓弧研磨 · 位置精準
- 刀桿優化 · 加工速度快



N9MT11T3R

R



R1.0~R3.0
不同圓弧刀片，
可替換於同款刀桿。



▶ 刀片 >>

- 正反圓弧倒角
- 刀片壽命長
- 刀片有4個切削刃口

NC2071: • 泛用材種，適合鋼鐵，鑄鐵
• 刀片圓弧研磨位置精準

刀片 半徑(R)	訂購編號	鍍層	材質	尺寸	尺寸	
					L	S
1.0	N9MT11T3R10-NC2071	TiN	P35		11.11	3.97
1.5	N9MT11T3R15-NC2071					
2.0	N9MT11T3R20-NC2071					
2.5	N9MT11T3R25-NC2071					
3.0	N9MT11T3R30-NC2071					



2

圓弧倒角刀

▶ 刀桿 >>

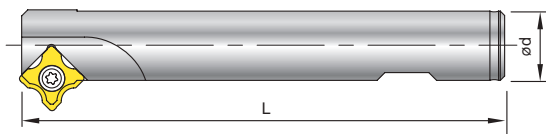
- 加工圓弧中心，可預先設定



訂購編號	Part No.	Ød	L	Z	螺絲	扳手
99616-16-25R	SB16-R1030-100	16	100	1		
99616-16-30R	SB16-R1030-120	16	120	1	 NS-35080 2.5 Nm	 NK-T15
99616-25-40R	BC25-R1030-150	25	150	4		

▶ 更多 >>

- 也可使用N9MT11T308LA刀片於前後倒角加工(詳見2-43頁)

R N9MT11T3R

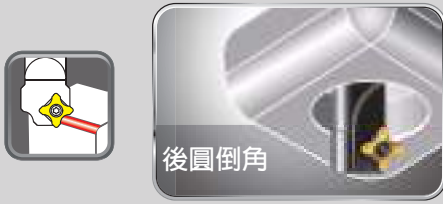

▶ 切削位置 >>

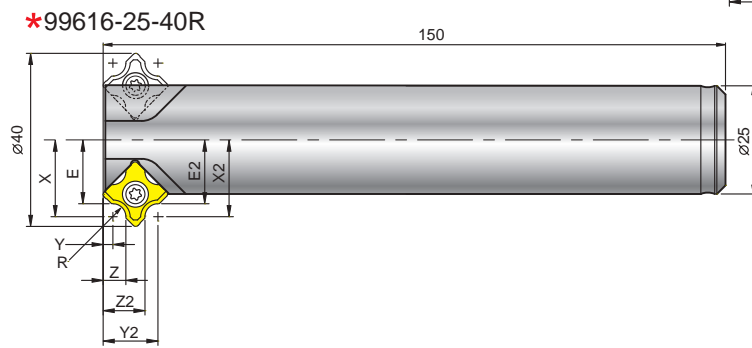
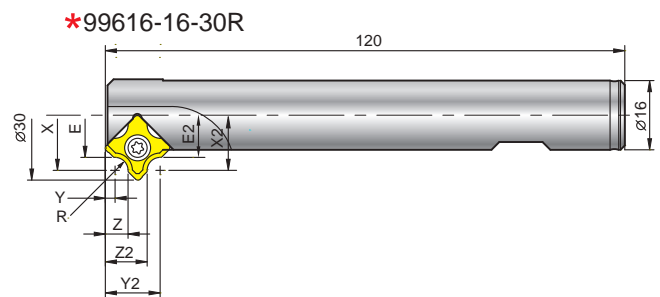
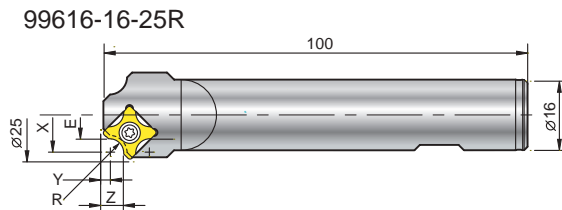

99616-16-30R & 99616-25-40R

* 前後倒圓角。

* 減少二次加工及修毛邊時間。

刀片 半徑	訂購編號	前倒角				後倒角				Z
		E	X	Y	Z	E2	X2	Y2	Z2	
R1.0	99616-16-25R	8.25	9.25	3.25	4.25	---	---	---	---	1
	99616-16-30R	10.75	11.75	3.25	4.25	10.75	11.75	11.65	10.65	1
	99616-25-40R	15.75	16.75	3.25	4.25	15.75	16.75	11.65	10.65	4
R1.5	99616-16-25R	8	9.5	3	4.5	---	---	---	---	1
	99616-16-30R	10.5	12	3	4.5	10.5	12	11.9	10.4	1
	99616-25-40R	15.5	17	3	4.5	15.5	17	11.9	10.4	4
R2.0	99616-16-25R	7.75	9.75	2.75	4.75	---	---	---	---	1
	99616-16-30R	10.25	12.25	2.75	4.75	10.25	12.25	12.15	10.15	1
	99616-25-40R	15.25	17.25	2.75	4.75	15.25	17.25	12.15	10.15	4
R2.5	99616-16-25R	7.5	10	2.5	5	---	---	---	---	1
	99616-16-30R	10	12.5	2.5	5	10	12.5	12.4	9.9	1
	99616-25-40R	15	17.5	2.5	5	15	17.5	12.4	9.9	4
R3.0	99616-16-25R	7.25	10.25	2.25	5.25	---	---	---	---	1
	99616-16-30R	9.75	12.75	2.25	5.25	9.75	12.75	12.65	9.65	1
	99616-25-40R	14.75	17.75	2.25	5.25	14.75	17.75	12.65	9.65	4

2

圓弧倒角刀

N9MT11T308LA 45°倒角工具

308
LA

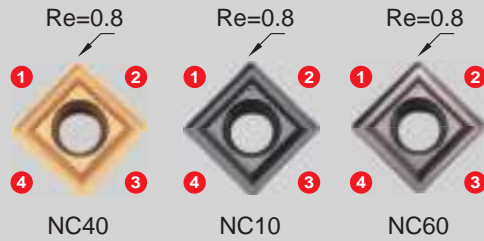

▶ 刀片 >>

- NC40:**
 - 泛用材種，適合鋼鐵，鑄鐵
 - 刀片有4個切削刃口
- NC10:**
 - 高正角切削刃口
 - 適用非鐵金屬，鑄鐵，不鏽鋼
 - 刀片有4個切削刃口
- NC60:**
 - 瓷金刀片，可加工硬化鋼到HRC56度
 - 刀片有4個切削刃口

訂購編號	鍍層	材質	尺寸		
			L	S	Re
N9MT11T308LA	NC40	TiN	11.11	3.97	0.8
	NC10	TiAN			
	NC60	Cermet			

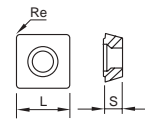

▶ 刀桿 >>

- 99616-28可作反向倒角和側向銑槽

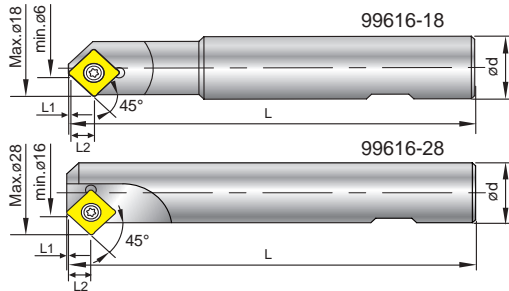

訂購編號	Part No.	倒角	Ød	L	L1	L2	⊕Z	刀片類型	螺絲 / 扳手
99616-18	SB20-C6-18	Ø6-Ø18	20	120	1.15	7.55	1	N9MT11T308LA	NS-35080 2.5 Nm NK-T15
99616-28	SB20-C16-28	Ø16-Ø28	20	120	1.15	7.55	1		

▶ 範例 >>

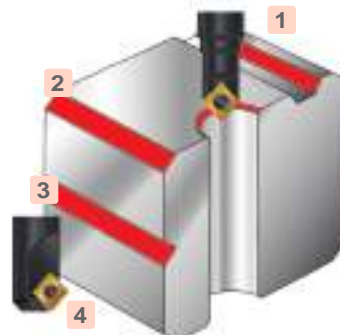
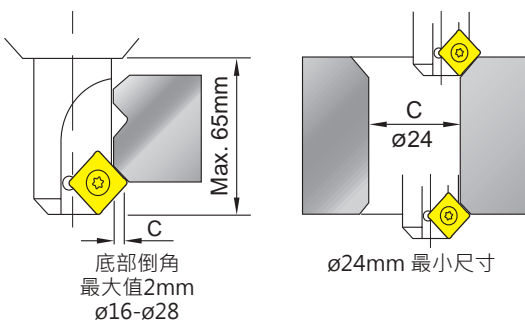

步驟	
1	內倒角與外倒角
2	側邊倒角
3	側槽
4	底部倒角

2

圓弧倒角刀

切削資料

▶ 車銑萬用鑽尺寸/深度表與 主軸/進給率計算

2

NC車銑萬用鑽

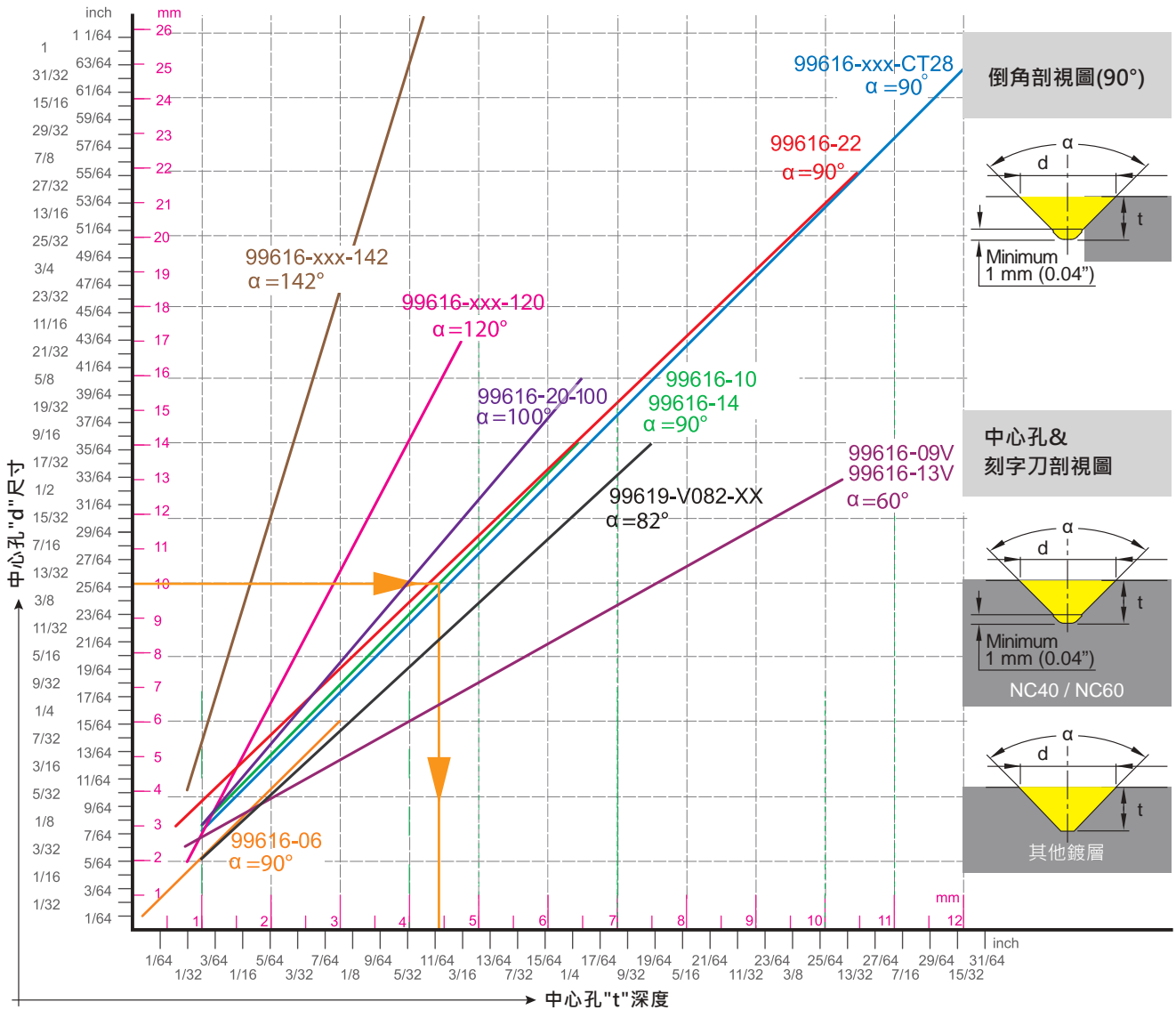

▶ 使用說明 >>

1. 中心尺寸“d”取得鑽孔深度“t”。
2. 點角“α”依使用之刀柄而不同。
3. 從“d”畫出水平線找出點角“α”。
4. 從交叉點畫出垂直線於底部找出中心孔“t”。“t”為NC程式的加工深度。
5. 中心孔的剖視圖會依刀片形狀而定，NC40及其他材質刀片有不同的剖視圖。
6. 尖點刀片不適用於倒角 1mm(0.04”) 最小間隙使用於平滑面。

▶ 計算機台轉速及進給率 >>

1. 使用“d”值與切削速Vc於資料表中計算機台轉速“S” (RPM)。
2. “F”進給率計算 $F = f \times S = \text{RPM} \times \text{IPR}$

公制		英吋	
$S = \frac{Vc \times 1000}{\pi \times d}$	d = 直徑 -mm S = 刀具轉速 -r.p.m. Vc = 切削速度 -m/min.	$S = \frac{(3.82 \times \text{SFM})}{d}$	d = 直徑 -inch S = 刀具轉速 -r.p.m. SFM = Surface Speed -ft./min.
$F = S \times f$	f = mm/rev. F = mm/min.	$F = \text{r.p.m.} \times \text{IPR}$	f = IPR = inch/rev. F = inch/min.

切削資料

▶ N9MT-CT >> 多功能刀片

- 選擇中心孔深度決定中心孔尺寸可根據 P.2-44頁 尺寸/深度表
- 機台轉速計算可取決於中心孔・倒角與車槽最大值。

★N9MT05T1CT / N9MT0602CT / V9MT0802CT 三款刀片之 f 值為表列降70%

中心孔	工件材質	Vc (m/min)	f (mm/rev.) [★]	刀片鍍層
	P 碳鋼	150~250	0.05~0.10	NC40, NC2071(H-NC40)
	合金鋼	100~200	0.04~0.08	NC40, NC5071
	M 不鏽鋼	65~125	0.03~0.06	NC10, NC60, NC40, NC2071, NC9036
	K 鑄鐵	80~150	0.05~0.10	NC40, NC10, NC5071
	N 非鐵金屬材質	150~300	0.05~0.10	NC10, NC9076, NC2071, NC9036
	S 鈦・鈦合金	40~80	0.03~0.08	NC9076, NC9036
	H 熱處理鋼40°~56°	30~60	0.03~0.08	NC60

*由於加工技術關係・刀片無放置於刀柄中心・
*刀片支撐面可增加50%進給率。

倒角	工件材質	Vc (m/min)	f (mm/rev.) [★]	刀片鍍層
	P 碳鋼	150~320	0.15~0.24	NC40, NC2071, NC5071
	合金鋼	100~250	0.12~0.20	NC40, NC2071, NC5071
	M 不鏽鋼	65~125	0.1~0.20	NC10, NC60, NC40, NC2071, NC9036
	K 鑄鐵	150~250	0.15~0.25	NC40, NC10, NC2071, NC5071
	N 非鐵金屬材質	150~320	0.15~0.25	NC10, NC9076, NC2071, NC9036
	S 鈦・鈦合金	40~80	0.03~0.08	NC9076, NC9036
	H 熱處理鋼40°~56°	30~60	0.03~0.08	NC60

銑槽	工件材質	Vc (m/min)	f (mm/rev.) [★]	刀片鍍層
	P 碳鋼	150~250	0.05~0.10	NC40, NC2071
	合金鋼	100~200	0.04~0.08	NC40, NC2071, NC5071
	M 不鏽鋼	65~125	0.03~0.06	NC10, NC60, NC40, NC2071, NC9036
	K 鑄鐵	80~150	0.05~0.08	NC40, NC10, NC2071, NC5071
	N 非鐵金屬材質	150~320	0.05~0.08	NC10, NC9076, NC2071, NC9036
	S 鈦・鈦合金	40~80	0.03~0.08	NC9076, NC9036
	H 熱處理鋼40°~56°	30~60	0.03~0.08	NC60

2

NC車銑萬用鑽

切削資料

▶ W 中心孔 >> 145°+90° W 中心孔

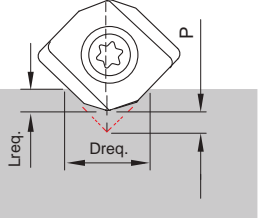
W 中心孔	公式										
	$P =$ 刀片尖點交叉處										
	$0.5 =$ 參數計算之固定值										
	$Lreq. =$ 鑽孔深度										
	$Dreq. =$ 需求尺寸										
	M4	M5	M6	M8	M10	M12	M14	M16	1/4-20 UNC	5/16-18 UNC	3/8-16 UNC
$P =$	1.17	1.48	1.76	2.39	2.97	3.59	4.19	4.88	1.80	2.30	2.78

W 中心孔	工件材質	Vc (m/min)	f (mm/rev.)	刀片鍍層
	P 碳鋼	150 ~ 300	0.05 ~ 0.15	NC2033
	P 合金鋼	120 ~ 250	0.05 ~ 0.10	
	M 不鏽鋼	80 ~ 150	0.04 ~ 0.08	
	K 鑄鐵	100 ~ 200	0.05 ~ 0.10	
	H 熱處理鋼50°	30 ~ 60	0.03 ~ 0.08	

▶ N9MT-RC 刀片 >> 圓弧倒角

主軸轉速與進給: 工具加工速度與進給速度 · 請依下列公式計算轉速及進給速率

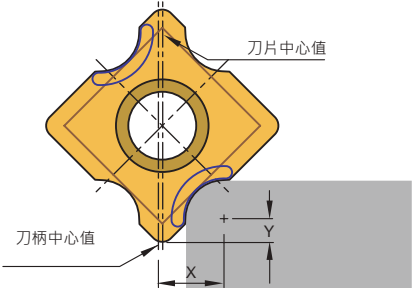
圓弧倒角	轉速計算	
	$d = 2 \times X$ mm	$d =$ 刀具尺寸預估值
	$S = \frac{Vc \times 1000}{d \times \pi}$ r.p.m.	$X =$ 刀具偏心值(參考 P.2-37~2-39 RC刀片)
	$F = S \times f$ mm/min.	$Vc =$ 切削速度 -m/min.
		$S =$ 刀具轉速 -r.p.m.
		$F =$ mm/min.
		$f =$ mm/rev.
	刀具於機台上的偏擺長度計算	
	$TL = TL' - Y,$	$X =$ 刀具偏心值(參考 P.2-37~2-39 RC刀片)
	$H = X$	$Y =$ 中心半徑距離(參考 P.2-37~2-39 RC刀片)
		$TL' =$ 刀具長度
		$TL =$ 刀具偏擺長度
		$H =$ 刀具偏擺半徑

RC 刀片	工件材質	Vc (m/min)	f (mm/rev.)	刀片鍍層
	P 碳鋼	150~320	0.05~0.10	NC40, NC2071, NC2033
	P 合金鋼	100~250	0.05~0.10	NC40, NC2071, NC2033
	P 高合金鋼	80~150	0.04~0.08	NC40, NC2071, NC2033
	M 不鏽鋼	65~125	0.05~0.10	NC9036
	K 鑄鐵	150~250	0.05~0.10	NC40, NC2071, NC2033
	N 鋁 · 含矽 <12%	150~320	0.05~0.10	NC9036, XP9000
	N 含矽 >12%	100~300	0.05~0.10	NC9036, XP9000
	N 銅	200~250	0.05~0.10	NC9036, XP9000
	N 黃銅 & 青銅	150~250	0.05~0.10	NC9036, XP9000
	S 鈦 · 鈦合金	40~80	0.03~0.08	NC9036
H 熱處理鋼50°	30~60	0.03~0.08	NC2033	

2

圓弧倒角刀

切削資料

▶ N9MT-R 刀片 >> 圓弧倒角 (四個切削刃口)

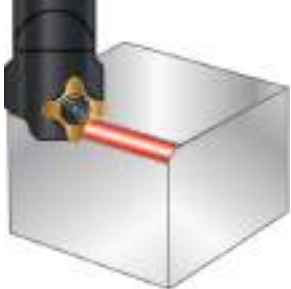
R 刀片	工件材質	Vc (m/min)	f (mm/rev.)	刀片鍍層
	P 碳鋼	150~320	0.05~0.10	NC2071
	合金鋼	100~250	0.04~0.08	NC2071
	高合金鋼	60~80	0.03~0.06	NC2071
	K 鑄鐵	150~250	0.05~0.10	NC2071

▶ LA 刀片 >> 45° 倒角

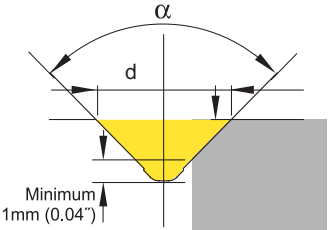
45° 倒角	公式
	$\alpha = \text{點角 } 90^\circ$
	$S = \frac{Vc \times 1000}{d \times \pi} \text{ r.p.m.}$
	$F = S \times f \text{ mm/min.}$
	$Vc = \text{切削速度 m/min. 或 ft./min.}$
	$S = \text{刀具轉速}$
	$f = \text{進給速度}$

45° 倒角	工件材質	Vc (m/min)	f (mm/rev.)	刀片鍍層
	P 碳鋼	150-320	0.05~0.10	NC40
	合金鋼	100-250	0.04~0.08	NC40
	高合金鋼	60-80	0.03~0.06	NC40
	M 不鏽鋼	65-125	0.03~0.06	NC10
	K 鑄鐵	150-250	0.05~0.10	NC10, NC40
	N 鋁·含矽 <12%	150-320	0.05~0.10	NC10
	含矽 >12%	100-300	0.05~0.10	NC10
	銅	200-250	0.05~0.10	NC10
	黃銅 & 青銅	150-250	0.05~0.10	NC10
	H 熱處理鋼40°~56°	60-80	0.05~0.10	NC60

2

圓弧倒角刀片

中心鑽 >>>

i-Center是耐久的註冊商標，
世界首創刀片式中心鑽，擁有多國專利
只要在使用首次設定刀具長度，大幅提昇換刀效率



- 2 個切削槽設計與鎢鋼中心鑽相同，可實現高速度與高進給
- 每片刀片有2個切削刃口



Features >>>

- ▶ **高速度，高進給**
 - 高強度刀桿，高強度刀片
 - 合金鋼可使用6000rpm · 600mm/min (0.1mm/rev.)
- ▶ **優異的重現性**
 - 重現度0.02mm
- ▶ **刀具長度穩定**
 - 刀片更換，刀長誤差在0.05mm以內
- ▶ **優異的刀具壽命**
 - 使用中心出水，可以大幅提高刀具壽命
 - 刀片幾何形狀設計優化，刀片材種和鍍層，均是最適合中心孔加工使用

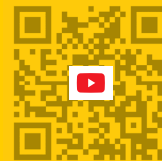

Applications

優異的刀片重現性，
更換刀片不用重新設定
刀具長度



DIN 332 Form R

Ø1.0~Ø10

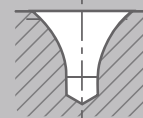

DIN 332 Form A

Ø2.0~Ø3.15

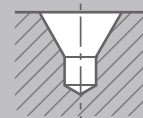

DIN 332 Form A+B

Ø1.0~Ø10

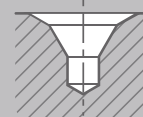

ANSI 60°

#2.0~#10

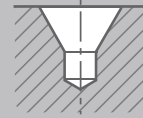

2

中心鑽

“世界首創刀片式中心鑽
大幅縮短設定時間，減少加工工時
刀具壽命增加，刀具成本降低。”

• 中心出水孔使高壓冷卻液快速直達切削刃口。

NC2057



- P35 鎢鋼底材, AL(L) 鍍層
- 適合鋼料，不鏽鋼及鑄鐵
- 雙刃切削設計

NC5074



- P40 鎢鋼底材，HELICA鍍層
- 特別適合小尺寸的I-Center (如IC08刀片)

NC2033



- K20F 鎢鋼底材，TIALN鍍層
- 適合鋼鐵，鑄鐵

DIN332 R型刀片

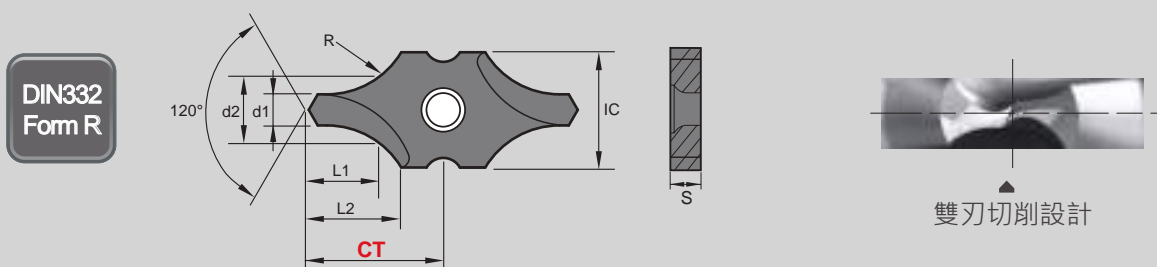

▶ DIN332 R型 >>

2

中心鑽

IC	訂購編號	鍍層	材質	d1	d2	L1	L2	R	S	CT ±0.025	
08	I9MT08T1R0100-NC5074	Helica	P40	1.00	+0.14 0	2.12	2.16	4.14	2.8	2.00	7.55
	I9MT08T1R0125-NC5074			1.25		2.65	2.74	4.64	3.5		7.90
	I9MT08T1R0160-NC5074			1.60		3.35	3.45	5.13	4.5		8.40
	I9MT08T1R0200-NC5074			2.00		4.25	4.45	6.08	5.65		9.10
10	I9MT1003R0100-NC2057	AlTiN+ TiSiN	P35	1.00	+0.14 0	2.12	2.16	4.72	2.8	3.00	12.35
	I9MT1003R0125-NC2057			1.25		2.65	2.74	5.22	3.5		
	I9MT1003R0150-NC2057			1.50		3.60	3.67	6.14	5.0		
	I9MT1003R0160-NC2057			1.60		3.35	3.45	5.32	4.5		
	I9MT1003R0200-NC2057			2.00	4.25	4.45	6.50	5.65			
	I9MT1003R0250-NC2057			2.50	5.30	5.59	7.66	7.15			
	I9MT1003R0300-NC2057			3.00	+0.18 0	5.70	6.92	9.50	10.00		
	I9MT1003R0315-NC2057			3.15	6.70	7.21	8.93	9.00			
12	I9MT12T2R0200-NC2033	TiAlN	K20F	2.00	+0.14 0	4.25	4.45	6.64	5.65	2.54	11.73
	I9MT12T2R0250-NC2033			2.50	5.3	5.59	8.11	7.15	13.00		
	I9MT12T2R0315-NC2033			3.15	6.7	7.21	9.63	9.0	14.00		
16	I9MT1603R0400-NC2033	TiAlN	K20F	4.00	+0.18 0	8.5	9.06	12.23	11.0	3.18	19.40
	I9MT1603R0500-NC2033			5.00	10.6	11.45	14.2	14.0	19.40		
20	I9MT2004R0630-NC2033	TiAlN	K20F	6.30	+0.22 0	13.2	14.63	18.2	18.0	4.76	28.40
	I9MT2004R0800-NC2033			8.00		17.0	18.63	20.44	22.5		28.30
25	I9MT2506R1000-NC2033	TiAlN	K20F	10.00		21.2	23.51	25.8	28.0	6.35	34.20

★ 接受IC32特製尺寸刀片，刀桿細節請詳見2-54頁。

DIN332 A+B型刀片

DIN332
Form A+B

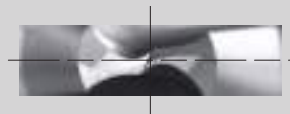
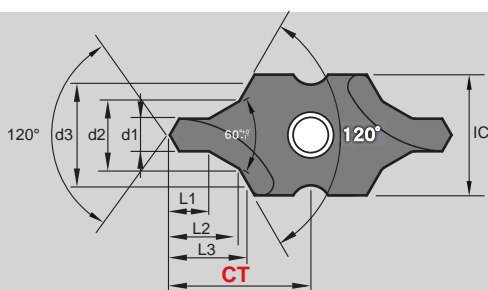

雙刃切削設計



► DIN332 A+B型 >>

2

中心鑽

IC	訂購編號	鍍層	材質	d1	d2	d3	L1	L2	L3	S	CT ±0.025	
08	I9MT08T1B0100-NC5074	Helica	P40	1.00	+0.14 0	2.12	3.15	1.3	2.21	2.51	2.00	7.55
	I9MT08T1B0125-NC5074			1.25		2.65	4.0	1.6	2.75	3.14		7.90
	I9MT08T1B0160-NC5074			1.60		3.35	5.0	2.0	3.46	3.93		8.40
	I9MT08T1B0200-NC5074			2.00		4.25	6.3	2.5	4.39	4.98		9.10
10	I9MT1003B0100-NC2057	AlTiN+ TiSiN	P35	1.00	+0.14 0	2.12	3.15	1.3	2.21	2.51	3.00	12.35
	I9MT1003B0125-NC2057			1.25		2.65	4.0	1.6	2.75	3.14		
	I9MT1003B0150-NC2057			1.50		3.18	4.50	2.0	3.45	3.84		
	I9MT1003B0160-NC2057			1.60		3.35	5.0	2.0	3.46	3.93		
	I9MT1003B0200-NC2057			2.00	4.25	6.3	2.5	4.39	4.98			
	I9MT1003B0250-NC2057			2.50	5.3	8.0	3.1	5.53	6.28			
	I9MT1003B0300-NC2057			3.00	+0.18 0	6.46	9.00	4.1	7.10	7.83		
	I9MT1003B0315-NC2057			3.15		6.7	10.0	3.9	6.90	7.85		
12	I9MT12T2B0200-NC2033	TiAlN	K20F	2.00	+0.14 0	4.25	6.3	2.5	4.39	4.98	2.54	11.73
	I9MT12T2B0250-NC2033			2.50		5.3	8.0	3.1	5.53	6.28		13.0
	I9MT12T2B0315-NC2033			3.15		6.7	10.0	3.9	6.90	7.85		14.0
16	I9MT1603B0400-NC2033	TiAlN	K20F	4.00	+0.18 0	8.5	12.5	5.0	8.9	10.03	3.18	19.4
	I9MT1603B0500-NC2033			5.00		10.6	16.0	6.3	11.15	12.68		19.4
20	I9MT2004B0630-NC2033	TiAlN	K20F	6.30	+0.22 0	13.2	18.0	8.0	13.98	15.33	4.76	28.4
	I9MT2004B0800-NC2033			8.00		17.0	*20	10.1	17.89	18.73		28.3
25	I9MT2506B1000-NC2033	TiAlN	K20F	10.00	+0.22 0	21.2	*25	12.8	22.5	23.57	6.35	34.2

★ 接受IC32特製尺寸刀片，刀桿細節請詳見2-54頁。

* 注意：d3尺寸與標準DIN332中心孔不同。

DIN332 A型、ANSI 60°刀片

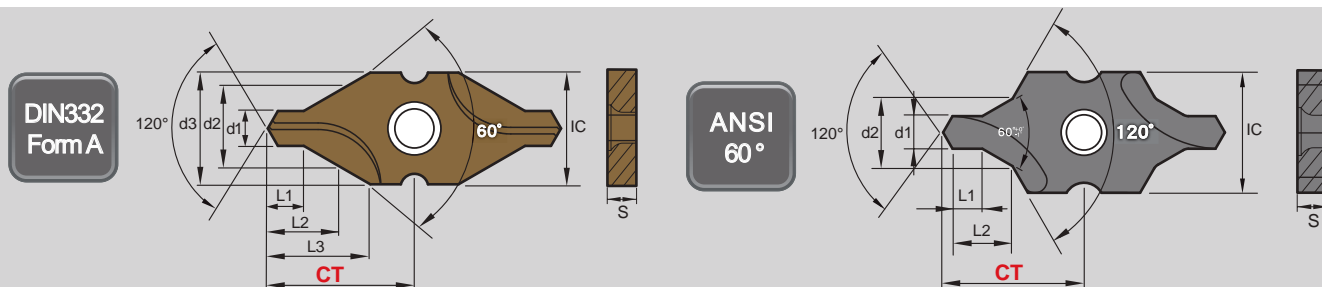

2

中心鑽



▶ DIN332 A型 >>

IC	訂購編號	鍍層	材質	d1		d2	d3	L1	L2	L3	S	CT ±0.025
08	I9MT08T1A0200-NC5074	Helica	P40	2.0	+0.14 0	4.25		2.15	4.10	7.35	2.00	10.5
	2.5			5.3								
	I9MT08T1A0315-NC5074			3.15	+0.18 0	6.7		3.23	6.30	7.43		



▶ ANSI 60° >>

IC	訂購編號	鍍層	材質	尺寸	d1		d2		L1		L2	S	CT ±0.025	
						mm		mm		mm	mm			
12	I9MT12T2A2-NC2033	TiAlN	K20F	#2	5/64	1.98	+0.14 0	3/16	4.76	5/64	1.98	4.4	12.6	
	I9MT12T2A3-NC2033			#3	7/64	2.78		1/4	6.35	7/64	2.78	5.9	2.54	13.8
	I9MT12T2A4-NC2033			#4	1/8	3.18		5/16	7.94	1/8	3.18	7.3		14.25
16	I9MT1603A5-NC2033	TiAlN	K20F	#5	3/16	4.76	+0.18 0	7/16	11.11	3/16	4.76	10.3	3.18	20.0
I9MT2004A6-NC2033	#6			7/32	5.56	1/2		12.7	7/32	5.56	11.8		27.75	
20	I9MT2004A7-NC2033			#7	1/4	6.35		5/8	15.88	1/4	6.35	14.6	4.76	28.5
	I9MT2004A8-NC2033	#8	5/16	7.94	+0.22 0		3/4	19.05	5/16	7.94	17.6		29.0	
25	I9MT2506A10-NC2033	#10	3/8	9.53		0.98"	25.0	3/8	9.53	22.9	6.35	34.9		

IC10 60°, 90°, 120° 中心孔 & 埋頭孔

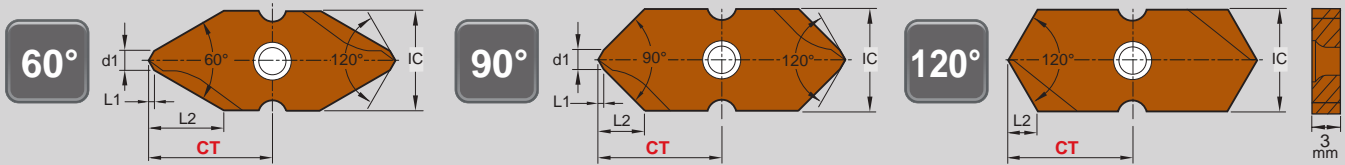

中心孔 & 埋頭孔 >>



▲ 雙刃切削設計

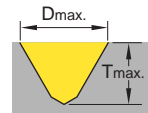

IC	角度	訂購編號	鍍層	材質	d1	L1	L2	Dmax.	Tmax.	CT ±0.025
10	60°	I9MT1003CT060-NC2057	AlTiN+TiSiN	P35	2	0.58	7.5	10	7.5	12.35
	90°	I9MT1003CT090-NC2057			2	0.58	4.6	10	4.6	
	120°	I9MT1003CT120-NC2057			-	-	2.9	10	2.9	

▶ 側固鋼柄 >>

- 高合金製作 · 硬度達HRC53
- 柄徑公差達h6

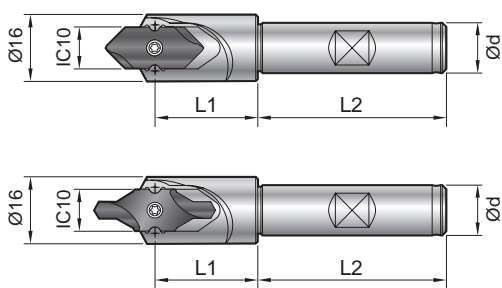

IC	訂購編號	Ød	L1	L2	螺絲 / 扳手
10	99616-IC10-12F	12	24.5	45	NS-25060 0.9Nm / NK-T7

▶ ER16 一體式錐柄 >>

訂購編號: 99816-IC10BH
(請參考頁面 9-182)

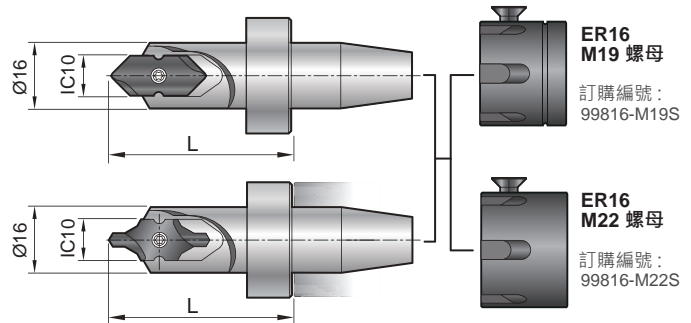

IC	訂購編號	L	螺絲 / 扳手
10	99816-IC10BH	45	NS-25060 0.9Nm / NK-T7

☀ 切削資料 >> (適用於中心孔 & 埋頭孔)

中心孔	工件材質	Vc (m/min.)	f (mm/rev.)			
			60°	90°	120°	
	P 低碳鋼 C<0.3%	120 ~ 250	0.04 ~ 0.20	0.15 ~ 0.25	0.10 ~ 0.30	● ○
	P 中碳鋼 C>0.3%	100 ~ 220	0.04 ~ 0.20	0.10 ~ 0.05	0.10 ~ 0.30	● ○
	P 低合金鋼 C<0.3%	100 ~ 200	0.03 ~ 0.16	0.08 ~ 0.20	0.10 ~ 0.25	● ○
	P 高合金鋼 C>0.3%	80 ~ 180	0.03 ~ 0.12	0.08 ~ 0.20	0.10 ~ 0.25	● ○
	M 不鏽鋼	60 ~ 120	0.02 ~ 0.10	0.06 ~ 0.12	0.08 ~ 0.15	● ≥ 5 bar ○
	N 鋁與非鐵金屬類	150 ~ 300	0.04 ~ 0.20	0.10 ~ 0.25	0.10 ~ 0.30	● ○
	P 低碳鋼 C<0.3%	120 ~ 250		0.20 ~ 0.50		● ○
	P 中碳鋼 C>0.3%	100 ~ 220		0.20 ~ 0.40		● ○
	P 低合金鋼 C<0.3%	100 ~ 200		0.15 ~ 0.40		● ○
	P 高合金鋼 C>0.3%	80 ~ 180		0.10 ~ 0.30		● ○
M 不鏽鋼	60 ~ 120		0.08 ~ 0.30		● ≥ 5 bar ○	
N 鋁與非鐵金屬類	150 ~ 300		0.20 ~ 0.50		● ○	

● 最好的 ○ 可能的

中心鑽刀柄



▶ 側固鋼柄 >>

- 高合金製作，硬度達HRC53
- 柄徑公差達h6

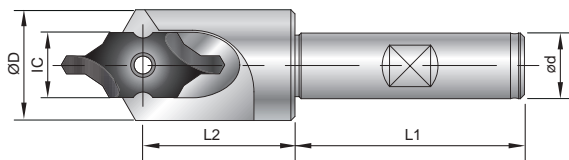

IC	訂購編號	Part No.	Ød	L1	L2	ØD	螺絲	扳手
08	99616-IC08-10F	BC10-IC08F	10	30	18.5	12	NS-25060 0.9 Nm	NK-T7
	99616-IC08-3/8F	BC3/8"-IC08F	3/8"					
10	99616-IC10-12F	SB12-IC10F	12	45	24.5	16	NS-25060 0.9 Nm	NK-T7
12	99616-IC12-16F	SB16-IC12F	16	48	30.5	21	NS-30072 2.0 Nm	NK-T9
	99616-IC12-5/8F	SB5/8"-IC12F	5/8"					
16	99616-IC16-16F	SB16-IC16F	16	48	37	27	NS-35080 2.5 Nm	NK-T15
	99616-IC16-5/8F	SB5/8"-IC16F	5/8"					
20	99616-IC20-20F	SB20-IC20F	20	50	51	32	NS-50125 5.5 Nm	NK-T20
	99616-IC20-3/4F	SB3/4"-IC20F	3/4"					
25	99616-IC25-25F	SB25-IC25F	25	56	56	43	NS-50125 5.5 Nm	NK-T20
	99616-IC25-1F	SB 1"-IC25F	1"					
★32	99616-IC32-32F	SB32-IC32F	32	60	62	54	NS-50125 5.5 Nm	NK-T20

★接受特製尺寸刀片。

▶ 動平衡圓柄 >>

- 高合金製作，硬度達HRC53
- G6.3 / 10,000 r.p.m.

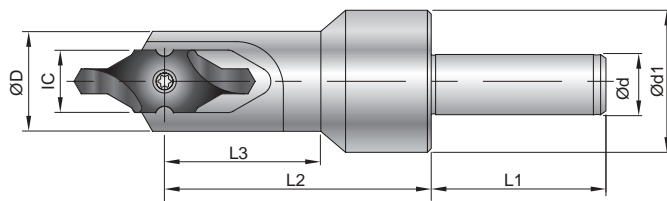

IC	訂購編號	Part No.	Ød	Ød1	L1	L2	L3	ØD	螺絲	扳手
08	99616-IC08-10B	BC10-IC08B	10	22	30	33.5	19	12	NS-25060 0.9 Nm	NK-T7
12	99616-IC12-12B	BC12-IC12B	12	34	48	51	30	21	NS-30072 2.0 Nm	NK-T9
16	99616-IC16-16B	BC16-IC16B	16	39	48	67	37	27	NS-35080 2.5 Nm	NK-T15
20	99616-IC20-20B	BC20-IC20B	20	49	50	86	51	32	NS-50125 5.5 Nm	NK-T20
25	99616-IC25-25B	BC25-IC25B	25	59	56	99	56	43	NS-50125 5.5 Nm	NK-T20

2

中心鑽



▶ 方型車刀座25x25 右手型 / 左手型 >>

- 適用於車床
- 刀座硬化至HRC40 · 材質穩定
- 特殊要求可訂製

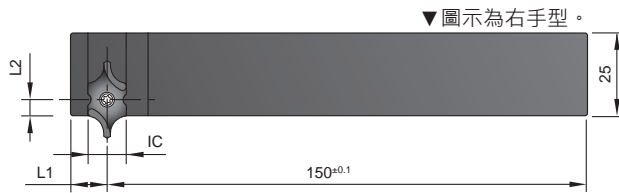

IC	訂購編號	L1	L2	螺絲	扳手
08	99616-IC08-R2525MF	8	3.25	NS-25060 0.9 Nm	NK-T7
	99616-IC08-L2525MF				
12	99616-IC12-R2525MF	11	4.9	NS-30072 2.0 Nm	NK-T9
	99616-IC12-L2525MF				
16	99616-IC16-R2525MF	13	4.9	NS-35080 2.5 Nm	NK-T15
	99616-IC16-L2525MF				

▶ 雙側固鋼柄 >> 特殊品

- 高合金製作 · 硬度達HRC53
- 適用於車床

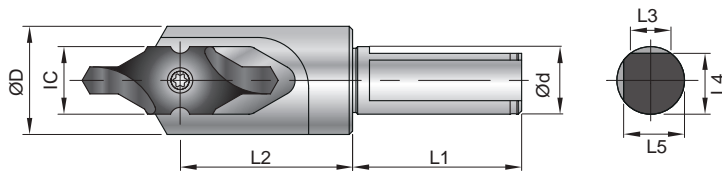

IC	訂購編號	Part No.	Ød	L1	L2	L3	L4	L5	ØD	螺絲	扳手
08	99616-IC08-10S	SL10-IC08S	10	30	18.5	6	9	9	12	NS-25060 0.9 Nm	NK-T7
12	99616-IC12-16S	SL16-IC12S	16	48	30.5	9.33	14.5	14.5	21	NS-30072 2.0 Nm	NK-T9
16	99616-IC16-16S	SL16-IC16S	16	48	37	9.33	14.5	14.5	27	NS-35080 2.5 Nm	NK-T15
20	99616-IC20-20S	SL20-IC20S	20	50	51	12	18	18	32	NS-50125 5.5 Nm	NK-T20
25	99616-IC25-25S	SL25-IC25S	25	56	56	13.57	23	23	43	NS-50125 5.5 Nm	NK-T20

2

中心鑽

測試基準刀片

- ▶ **主要功能** >>
 - 車床加工時，檢測刀具與主軸同心度
 - 基準刀片只有一個測試棒
 - 同心度：±0.01mm

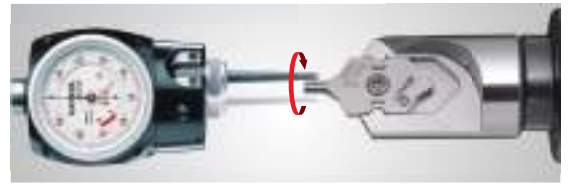

IC08	IC10	IC12	IC16	IC20
I9MT08T1-MM	I9MT1003-MM	I9MT12T2-MM	I9MT1603-MM	I9MT2004-MM

2

中心鑽

中心高調整刀座

- ▶ **主要功能** >>
 - 可調整刀具中心高度，避免刀具不對中心產生刀具斷裂
 - 適用中心鑽，定位鑽，車銑萬用鑽，鉸刀
 - 主結構由2個滑座組成，內套筒需鎖固切削刀具
 - 內外套筒移動，可以產生中心高度變化，進而校準刀具的中心高度

▶ **規格編號:99600-320H** >> 類型：SB32-IDER20

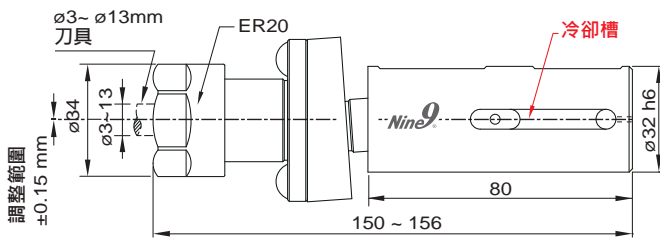

▶ **規格編號:99600-400H** >> 類型：SB40-ID16

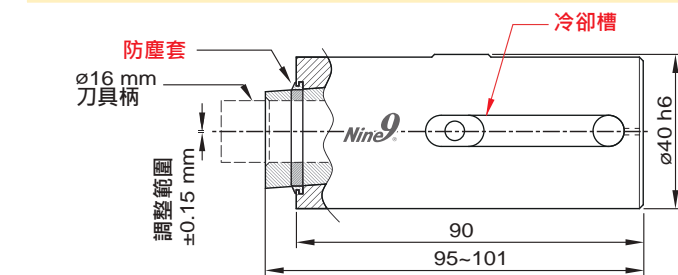

▶ **應用** >>

- CNC車床的刀座高度不精準
- 刀具中心可調高度±0.15mm
- 刀具軸向最大移動距離6mm

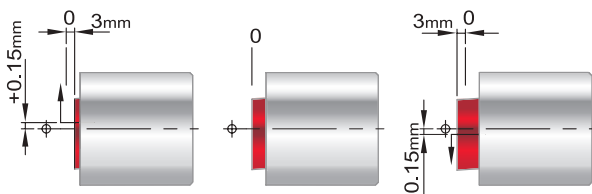

4mm 六角扳手固定螺絲



兩組螺絲固定內孔刀座

運用4mm六角扳手調整中心高度

性能

▶ 最佳選擇 >>

- 高速與進給率減少切削時間。
- 特殊設計延長刀具壽命與轉換時間。

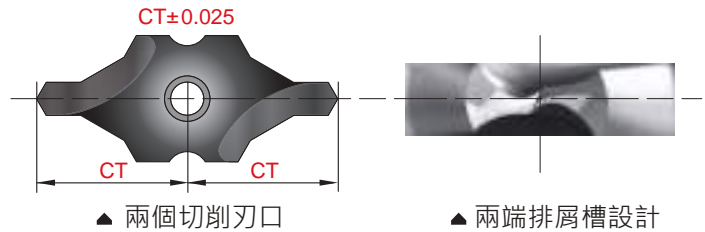

▲ 兩個切削刃口

▲ 兩端排屑槽設計

▶ 對照 >>

- 工件: 低合金鋼 850 N/mm²
- 機種: VMC BT40與內部冷卻。

刀桿直徑: Ø3.15 mm 鑽孔深度: 7.2 mm				
對照		i-Center	HSS 中心鑽 (TiN鍍層)	鎢鋼材質鑽頭
切削速度	m/min.	65	17	65
主軸轉速	r.p.m.	6570	1718	6570
進給速度 f =	mm/rev.	0.12	0.02	0.1
進給速度 F =	mm/min.	788.4	34.4	657
冷卻膠		外部 / 內部	外部	外部
加工時間	秒	0.55	12.5	0.65
每一刃口加工件數		7000	700	5000

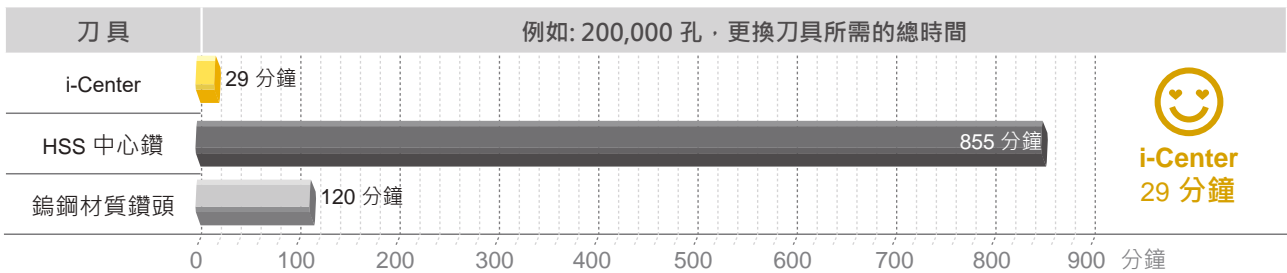
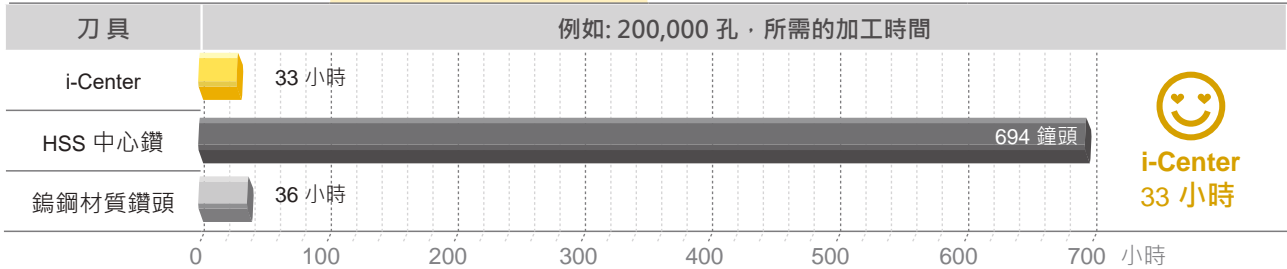

▶ 切削面光潔度 >>

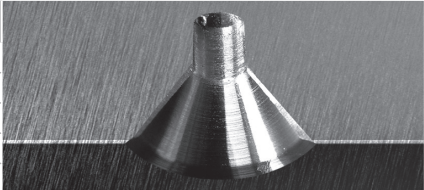
i-Center 刀片	SCM440 材質		
19MT1603B0500 NC2033	Vc	60 m/min.	
	S	3800 r.p.m.	
	f	0.1 mm/rev.	
	F	380 mm/min.	
	Ap	13.5 mm	

```

Perthometer M1
Object
Name
#
Lt 5.600 mm
Ls Standard 2.50 µm
Lc 0.900 mm
Ra 0.562 µm
Rz 3.26 µm
Rmax 3.61 µm
RPr(0.5,-0.5) 68 /c

R Profile
Lc 0.800 mm
VER 2.50 µm
    
```

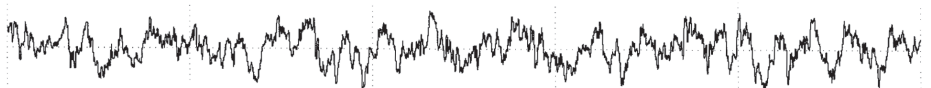

i-Center 所需型式

▶ 公司 >>

▶ 挑戰或改善 >>

下列資訊需於客戶討論時確認

機台	
機台種類	
主軸轉速	Max. r.p.m.
主軸馬達	<input type="checkbox"/> KW <input type="checkbox"/> HP
冷卻	<input type="checkbox"/> NO
	<input type="checkbox"/> If yes, <input type="checkbox"/> 外部的 <input type="checkbox"/> 內部的 桿(psi)
原有刀具	
切削速度	<input type="checkbox"/> HSS <input type="checkbox"/> 鎢鋼 m/min. SFM
其他	
進給率	mm/rev. inch/rev.
工件	
材質編碼	
中心孔類型	<input type="checkbox"/> R <input type="checkbox"/> A <input type="checkbox"/> B <input type="checkbox"/> C <input type="checkbox"/> 附件圖面
其他需求	<input type="checkbox"/> 表面粗糙度
	<input type="checkbox"/> 公差

▶ 特殊刀桿尺寸 >>

- 特殊刀柄請填寫D1與L4。
- 如附件中圖面
- 公制 英吋

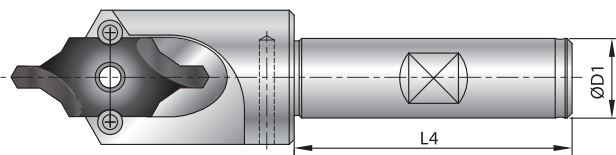

尺寸表	A1	A2	A3	ød1	ød2	ød3
尺寸						
公差	--	+0° -1°	±1°	±0.05	±0.05	--

尺寸表	L1	L2	L3	R	øD1	L4
尺寸						
公差	±0.05	±0.05	±0.05	±0.5	h6	--

▶ 中心孔公差 >>

- 請提供工件圖面。
- 可選擇下列其中之一。

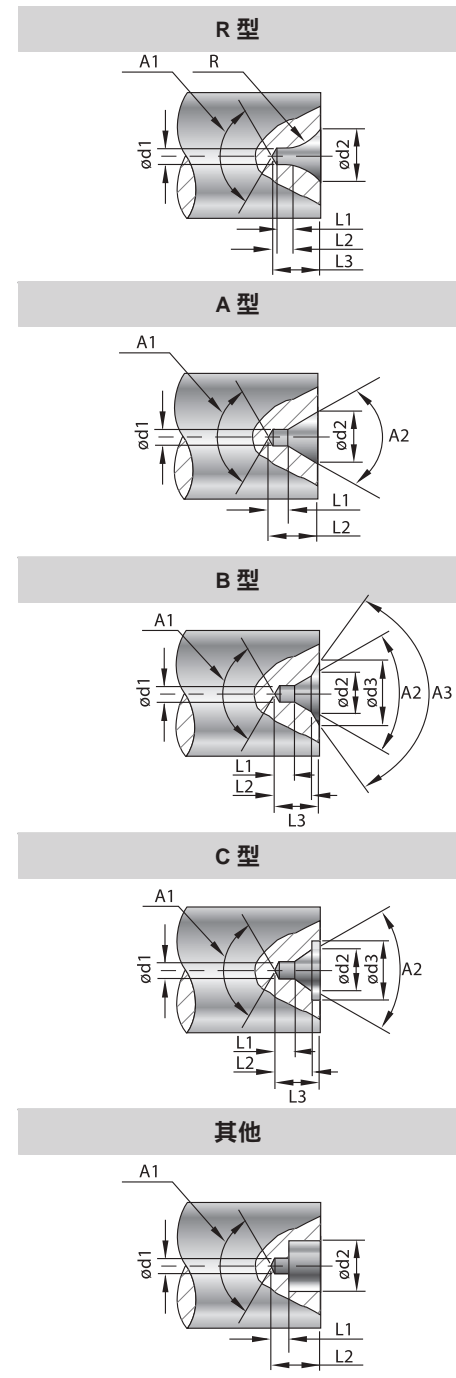

技術規範

ISO 2541-1972 / DIN332

▶ 60° 中心孔

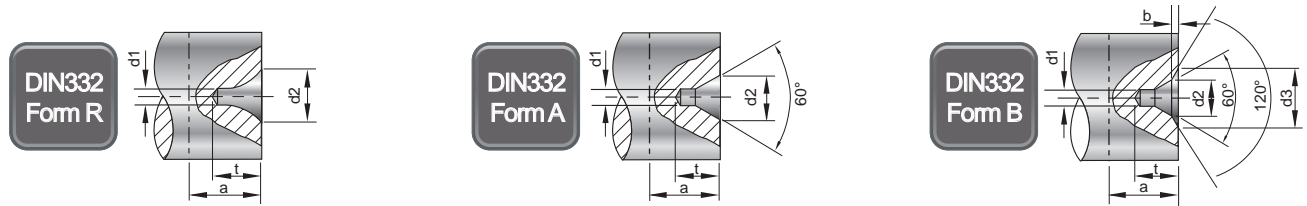

STD	DIN332 R 型 ISO 2541-1972			DIN332 A 型 ISO 866-1975			DIN332 B 型 ISO 2540 1973					
	d1	d2	t	a	d2	t	a	d2	b	d3	t	a
1	2.12	1.9	3	2.12	1.9	3	2.12	0.3	3.15	2.2	3.5	
1.25	2.65	2.3	4	2.65	2.3	4	2.65	0.4	4	2.7	4.5	
1.6	3.35	2.9	5	3.35	2.9	5	3.35	0.5	5	3.4	5.5	
2	4.25	3.7	6	4.25	3.7	6	4.25	0.6	6.3	4.3	6.6	
2.5	5.3	4.6	7	5.3	4.6	7	5.3	0.8	8	5.4	8.3	
3.15	6.7	5.8	9	6.7	5.9	9	6.7	0.9	10	6.8	10	
4	8.5	7.4	11	8.5	7.4	11	8.5	1.2	12.5	8.6	12.7	
5	10.6	9.2	14	10.6	9.2	14	10.6	1.6	16	10.8	15.6	
6.3	13.2	11.4	18	13.2	11.5	18	13.2	1.4	18	12.9	20	
8	17	14.7	22	17	14.8	22	17	1.6	22.4	16.4	25	
10	21.2	18.3	28	21.2	18.4	28	21.2	2	28	20.4	31	

2

中心鑽

▶ R 型 中心孔優勢

60° 中心底座	90° 中心底座	中心孔與偏心值
----------	----------	---------

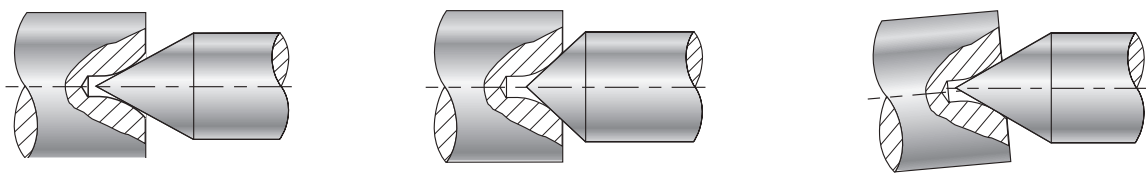

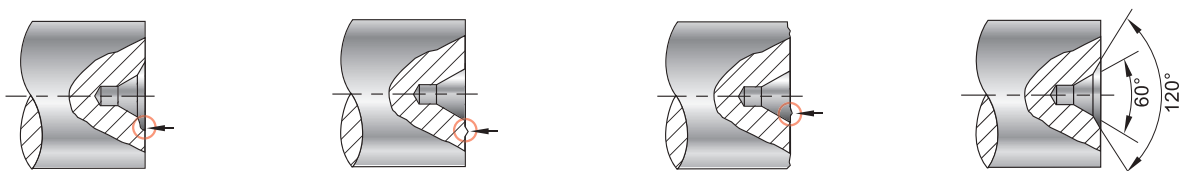

▶ B 型 中心孔優勢

避免在運送途中碰撞	毛邊	工件的粗糙表面	整體解決方案
-----------	----	---------	--------

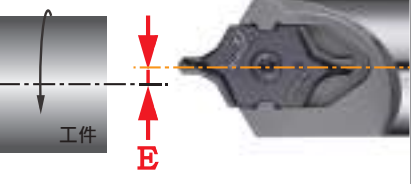
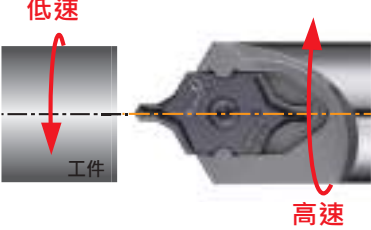

技術規範

► 使用之前請注意下列應用要點:

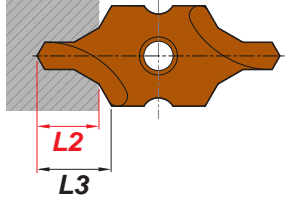
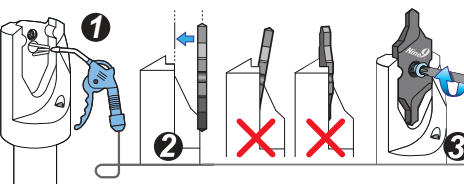
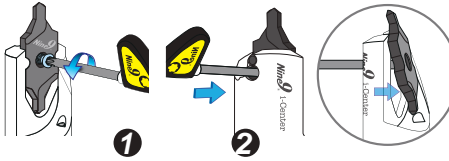
中心定位	Driving Tool	中心高調整刀座
<p>偏心值 E 須小於 0.02mm。</p> 	<p>低速 : 高速 1 : 3</p> 	<p>CNC車床偏心值如大於0.15mm，請使用中心高調整座。(詳見P.2-56)</p> 
中心出水孔	刀片A+B型	刀片鎖固
<p>建議使用中心出水</p> 	<p>當加工深度到達L2時，請降低轉速30%並且保持一樣的機台進給。</p> 	 <p>取下刀片</p> 

應用

多種定點鑽應用與產品-發動機·傳動齒輪箱·軸心·馬達·研磨零件·主軸·齒輪減速機·冷卻扇·通用...



切削資料

▶ Ø1~Ø3.15 (#2~#4)

工件材質	Vc (m/min.)	d1	IC08 / IC10		IC12			
			Ø1~1.25	Ø1.6~3.15	Ø2 (#2)	Ø2.5 (#3)	Ø3.15 (#4)	
P 低碳鋼 C<0.3% 中碳鋼 C>0.3% 低合金鋼 C<0.3% 高合金鋼 C>0.3%	< 80	S r.p.m.	2000 ~ 10000	1600 ~ 8000	1600 ~ 8000	1400 ~ 7000	1200 ~ 6000	● ○
		f mm/rev.	0.02~0.03~0.05	0.03~0.05~0.06	0.04~0.06~0.08	0.06~0.08~0.10	0.08~0.10~0.12	● ○
	< 70	S r.p.m.	2000 ~ 9000	1600 ~ 7200	1600 ~ 7200	1400 ~ 6300	1200 ~ 5400	● ○
		f mm/rev.	0.02~0.03~0.05	0.03~0.04~0.05	0.03~0.04~0.05	0.06~0.08~0.10	0.08~0.10~0.12	● ○
< 65	S r.p.m.	2000 ~ 8000	1600 ~ 6400	1600 ~ 6400	1400 ~ 5600	1200 ~ 4800	● ○	
	f mm/rev.	0.01~0.02~0.04	0.02~0.03~0.05	0.02~0.03~0.05	0.04~0.06~0.08	0.06~0.08~0.10	● ○	
< 60	S r.p.m.	1000 ~ 6000	800 ~ 4800	800 ~ 4800	700 ~ 4200	600 ~ 3600	● ○	
	f mm/rev.	0.01 ~ 0.02	0.01~0.02~0.04	0.01~0.02~0.04	0.02~0.04~0.06	0.04~0.06~0.08	● ○	
M 不鏽鋼	< 20	S r.p.m.	1000 ~ 3000	800 ~ 2400	800 ~ 2400	700 ~ 2100	600 ~ 1800	● ○
f mm/rev.		0.003 ~ 0.01	0.005 ~ 0.02	0.01 ~ 0.02	0.01~0.02~0.03	0.02~0.03~0.05	≥ 5 bar	● ○
K 鑄鐵	< 70	S r.p.m.	2000 ~ 9000	1600 ~ 7200	1600 ~ 7200	1400 ~ 6300	1200 ~ 5400	Air
f mm/rev.		0.01~0.02~0.04	0.02~0.04~0.06	0.02~0.04~0.06	0.04~0.06~0.08	0.06~0.08~0.10	Air	
N 鋁與非鐵金屬類	< 200	S r.p.m.	6000 ~ 20000	4800 ~ 16000	4800 ~ 16000	4200 ~ 14000	3600 ~ 12000	● ○
		f mm/rev.	0.01~0.02~0.03	0.01~0.02~0.04	0.01~0.02~0.04	0.02~0.03~0.05	0.02~0.04~0.06	● ○

● Best ○ Possible

▶ Ø4~Ø10 (#5~#10)

工件材質	Vc m/min.	d1	IC16		IC20			IC25	
			Ø4 (#5)	Ø5 (#6)	Ø6.3 (#7)	Ø8 (#8)	Ø10 (#10)		
P 低碳鋼 C<0.3% 中碳鋼 C>0.3% 低合金鋼 C<0.3% 高合金鋼 C>0.3%	< 80	S r.p.m.	1000 ~ 5000	900 ~ 4500	800 ~ 4000	700 ~ 3500	600 ~ 3000	● ○	
		f mm/rev.	0.08~0.12~0.14	0.10~0.12~0.16	0.10~0.14~0.16	0.12~0.15~0.18	0.14~0.18~0.20	● ○	
	< 70	S r.p.m.	1000 ~ 4500	900 ~ 4050	800 ~ 3600	700 ~ 3150	600 ~ 2700	● ○	
		f mm/rev.	0.08~0.12~0.14	0.10~0.12~0.16	0.10~0.14~0.16	0.12~0.15~0.18	0.14~0.18~0.20	● ○	
< 65	S r.p.m.	1000 ~ 4000	900 ~ 3600	800 ~ 3200	700 ~ 2800	600 ~ 2400	● ○		
	f mm/rev.	0.06~0.08~0.10	0.08~0.10~0.12	0.08~0.12~0.14	0.10~0.14~0.16	0.12~0.16~0.20	● ○		
< 60	S r.p.m.	500 ~ 3000	450 ~ 2700	400 ~ 2400	350 ~ 2100	300 ~ 1800	● ○		
	f mm/rev.	0.04~0.06~0.08	0.06~0.08~0.10	0.08~0.10~0.12	0.10~0.14~0.16	0.10~0.14~0.16	● ○		
M 不鏽鋼	< 25	S r.p.m.	500 ~ 1500	450 ~ 1350	400 ~ 1200	350 ~ 1050	300 ~ 900	● ○	
f mm/rev.		0.02~0.04~0.06	0.02~0.04~0.06	0.04~0.06~0.08	0.04~0.06~0.08	0.05~0.07~0.10	≥ 5 bar	● ○	
K 鑄鐵	< 70	S r.p.m.	1000 ~ 4500	900 ~ 4050	800 ~ 3600	700 ~ 3150	600 ~ 2700	Air	
		f mm/rev.	0.06~0.08~0.10	0.08~0.10~0.12	0.08~0.12~0.14	0.10~0.14~0.16	0.12~0.16~0.18	Air	
N 鋁與非鐵金屬類	< 200	S r.p.m.	3000 ~ 10000	2700 ~ 9000	2400 ~ 8000	2100 ~ 7000	1800 ~ 6000	● ○	
		f mm/rev.	0.02~0.04~0.06	0.04~0.06~0.08	0.04~0.06~0.08	0.06~0.08~0.10	0.06~0.08~0.10	● ○	

● Best ○ Possible

▶ 計算機台轉速及進給率

- 1.使用"d1"值與切削速Vc於資料表中計算機台轉速"S"(r.p.m.)。
- 2."F"進給率計算 F = S x f = IPR X r.p.m

公制	
$S = \frac{Vc \times 1000}{\pi \times d}$	d1 = 直徑 -mm S = 刀具轉速 -r.p.m. Vc = 切削速度 -m/min.
F = S x f	f = mm/rev. F = mm/min.

英吋	
$S = \frac{(3.82 \times SFM)}{d}$	d1 = 直徑-inch S = 刀具轉速-r.p.m. SFM = Surface Speed-ft./min.
F = r.p.m. x IPR	f = IPR = inch/rev. F = inch/min.





雕刻刀 >>>

30° / 45° / 60° / 90°

雕刻刀具的革命新概念 - 捨棄式雕刻刀
在各種材料上提供高品質的雕刻。
高速度與高進給為您縮短加工時間。

P M K N H S

▶ **更換刀片不用重新設定刀具長度**

- 每片刀片有2個切削刃口
- 優異的刀片重現性



Features >>>

▶ **高切削正角**

- 捨棄式刀片
- 適用所有材料，如塑膠，非鐵金屬，鋁合金，銅合金，碳鋼，不鏽鋼

▶ **精密研磨**

- 全研磨刀片
- 銅合金，鋁合金，不鏽鋼雕刻表面優異，不產生毛邊

▶ **高速度，高進給**

- 高速切削，最高轉速可達40,000rpm
- 高進給率，鋁合金可達0.08mm/rev，不鏽鋼可達0.05mm/rev
- 高速度減少雕刻加工時間





Applications

- 適用於產品編碼、數字刻盤、記號、商標刻字及所有NC程式系統文字雕刻。

Ultrasonic welding drum



模具 & 齒輪



3

雕刻刀



“ 廣泛應用於機械產業，醫療產業，國防產業，模具產業，汽機車產業，齒輪，培林以及精品產業 ”

數字刻盤

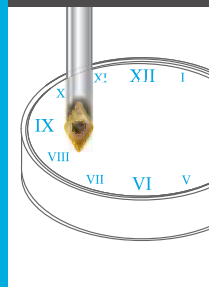

產品序號

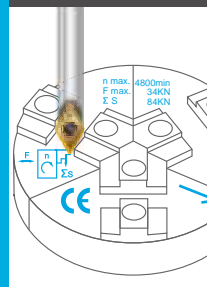

商標刻字





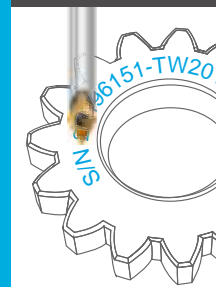







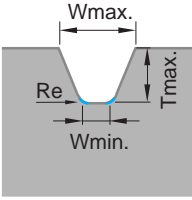







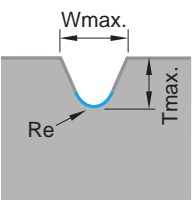



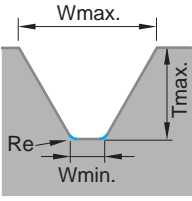

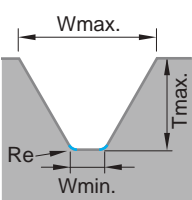
流水編號

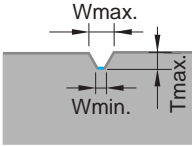

雕刻刀快選系統

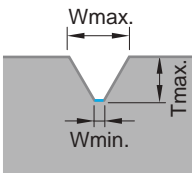
3

雕刻刀

系列	形狀	角度	刀片	Wmin.	Wmax.	Tmax.	刀桿	
X060 系列	 <p>圓鼻尖</p>	30°	 X060A30W...	0.2	0.52	0.6	 99619-X060... Ø6, Ø8	
		45°	 X060A45W...		0.86	0.8		
		60°	 X060A60W...		1.36	1.0		
		90°	 X060A90W...		0.1	1.1		0.5
			 X060A120W...		0.2	2.2		1.0
			 X060A142W...		0.1	2.53		0.7
	 <p>圓球尖</p>	30°	 X060A30R...	Re: 0.2	0.63	0.6		
		45°	 X060A45R...		0.93	0.8		
		60°	 X060A60R...		1.39	1.0		
	V045 V060 系列	 <p>圓鼻尖</p>	45°	 V04506T1W	0.45	2.1		2.0
0.65								
 <p>圓鼻尖 / 平口</p>		60°	 V06006T1W	0.25	1.1	0.8	 V06006T1W Ø4, Ø6, Ø8	
	0.45			2.7	2.0			
			 V06006T1W	0.65	2.7	2.0		
W060 系列	 <p>平口</p>	60°	 W06004S	0.1	0.33	0.2	 99619-W060... Ø4	
				0.2	0.66	0.4		
				0.3	0.99	0.6		
N9MT-W 系列	 <p>平口</p>	60°	 N9MT080201W -60-NC40	0.2	1.1	0.8	 99616-10...SW Ø10, Ø3/8"	
		90°	 N9MT080201W	0.2	2.0	0.9		

X060 – 圓鼻尖雕刻刀片



圓鼻尖

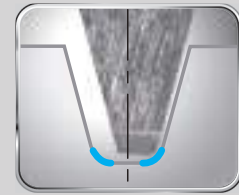

▶ 刀片 >>

NC2032: • 應用於 < HRC40 之鋼材，合金鋼，鑄鐵

NC2035: • ALDURA 鍍層
• 應用於硬化鋼可達 HRC56

XP9001: • 應用於非鐵金屬，鋁合金，銅合金，
塑膠，壓克力

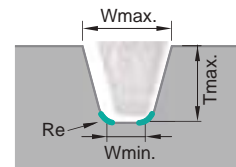

角度	訂購編號	鍍層	材質	尺寸			Wmin.	Wmax.	Tmax.
				L	S	Re			
30°	X060A30W020R	NC2032	TiAlN	6	2.05	0.04	0.20	0.52	0.6
		NC2035	ALDURA						
		XP9001	Polished						
45°	X060A45W020R	NC2032	TiAlN	6	2.05	0.04	0.20	0.86	0.8
		NC2035	ALDURA						
		XP9001	Polished						
60°	X060A60W020R	NC2032	TiAlN	6	2.05	0.04	0.20	1.36	1.0
		NC2035	ALDURA						
		XP9001	Polished						
90°	X060A90W010R	NC2032	TiAlN	6	2.05	0.02	0.10	1.1	0.5
		NC2035	ALDURA						
		XP9001	Polished						
	X060A90W020R	NC2032	TiAlN	6	2.05	0.04	0.20	2.2	1.0
		NC2035	ALDURA						
		XP9001	Polished						
120°	X060A120W010R	NC2032	TiAlN	6	2.05	0.02	0.10	2.53	0.7
142°	X060A142W010R	NC2032	TiAlN	6	2.05	0.02	0.10	2.42	0.4

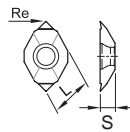

3

雕刻刀

▶ 刀桿 >>

- 共用 X060 所有刀片
- 可裝置 6 刃去毛邊刀片
- XL (100mm 加長型)，建議使用於鋁合金或軟材雕刻，不平衡量 < 0.6gm

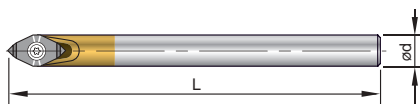

Ø6



Ø8

訂購編號	Part No.	材質	Ød	L	螺絲	扳手
99619-X060-06	BC06-CT-X060	鋼	6	40		
99619-X060-06L	BC06-CT-X060-60L	鎢鋼	6	60		
99619-X060-06LS	BC06-CT-X060-60LS	鋼	6	60	NS-22044 0.9Nm	NK-T7
99619-X060-06XL	BC06-CT-X060-100L	鎢鋼	6	100		
99619-X060-08	BC08-CT-X060	鋼	8	60		

30°
45°
60°

X060 – 圓球尖雕刻刀片

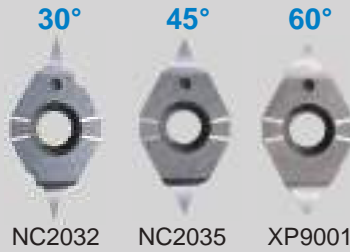
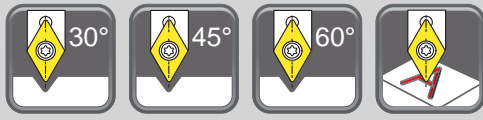

圓球尖



▶ 刀片 >>

NC2032: • 應用於 < HRC40之鋼材 · 合金鋼 · 鑄鐵

NC2035: • ALDURA鍍層
• 應用於硬化鋼可達HRC56

XP9001: • 應用於非鐵金屬 · 鋁合金 · 銅合金 · 塑膠 · 壓克力

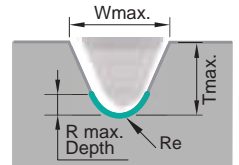

3

雕刻刀

角度	訂購編號	鍍層	材質	尺寸			R max. Depth	Wmax.	Tmax.	
				L	S	Re				
30°	X060A30R020	NC2032	TiAlN	6	2.05	0.2	0.15	0.84	0.6	
		NC2035	ALDURA							K20F
		XP9001	Polished							
45°	X060A45R020	NC2032	TiAlN	6	2.05	0.2	0.12	1.1	0.8	
		NC2035	ALDURA							K20F
		XP9001	Polished							
60°	X060A60R020	NC2032	TiAlN	6	2.05	0.2	0.10	1.39	1.0	
		NC2035	ALDURA							K20F
		XP9001	Polished							

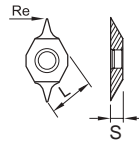

▶ 刀桿 >>

- 共用X060所有刀片
- 可裝置6刃去毛邊刀片
- XL (100mm加長型) · 建議使用於鋁合金或軟材雕刻 · 不平衡量 < 0.6gm

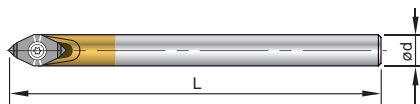

訂購編號	Part No.	材質	Ød	L	螺絲	扳手
99619-X060-06	BC06-CT-X060	鋼	6	40	NS-22044 0.9Nm	NK-T7
99619-X060-06L	BC06-CT-X060-60L	鎢鋼	6	60		
99619-X060-06LS	BC06-CT-X060-60LS	鋼	6	60		
99619-X060-06XL	BC06-CT-X060-100L	鎢鋼	6	100		
99619-X060-08	BC08-CT-X060	鋼	8	60		

45° 雕刻刀

V045



▶ 刀片 >>

- NC2032:**
 - 刀片壽命長
 - 泛用於鋼鐵HRC30 ~ 50，合金鋼，鑄鐵
- NC2071:**
 - 強壯的刀尖設計，切深0.2mm以上佳
 - 泛用於 < HRC30 之鋼鐵，非鐵金屬，不鏽鋼
- NC9031:**
 - 非常銳利的高正角切削
 - 非鐵金屬，鋁合金，銅合金，鈦合金，塑膠，壓克力
 - 軟材切深 0.2mm 以下建議使用

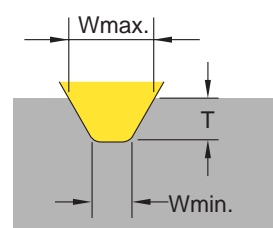

角度	訂購編號	鍍層	材質	Re	尺寸			W		T	
					L	S	Re	Wmin.	Wmax.	Tmin.	Tmax.
45°	V04506T1W06	NC2071	TiN		6.35	2.0	0.2	0.65	2.1	0.20	2.0
		NC2032	TiAlN					0.65		0.20	
		NC9031	TiN					0.45		0.05	

3

雕刻刀

▶ 刀桿 >>

- 熱縮型刀把，建議使用鎢鋼柄刀桿
- XL (100mm加長型)，建議使用於鋁合金或軟材雕刻，不平衡量 < 0.6gm

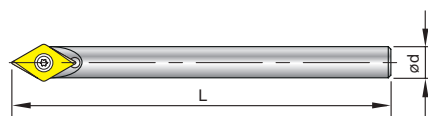

角度	訂購編號	Part No.	材質	Ød	L	螺絲	扳手
45°	99619-V045-06	BC06-CT-V045	鋼	6	40		
	99619-V045-06L	BC06-CT-V045-60L	鎢鋼		60		
	99619-V045-06XL	BC06-CT-V045-100L	鎢鋼		100		
	99619-V045-08	BC08-CT-V045	鋼		8		

V060 60° 雕刻刀



▶ 刀片 >>

- NC2032:** • 刀片壽命長
• 泛用於鋼鐵HRC30 ~ 50 · 合金鋼 · 鑄鐵
- NC2071:** • 強壯的刀尖設計 · 切深0.2mm以上佳
• 泛用於 < HRC30之鋼鐵 · 非鐵金屬 · 不鏽鋼
- NC2035:** • ALDURA鍍層 · 應用於硬化鋼可達HRC56
- NC9031:** • 非常銳利的高正角切削
• 非鐵金屬 · 鋁合金 · 銅合金 · 鈦合金 · 塑膠 · 壓克力
- NC9036:** • DLC鍍層 · 非常銳利的刃口設計
• 非鐵金屬 · 鋁合金 · 銅合金 · 鈦合金 · 塑膠 · 壓克力

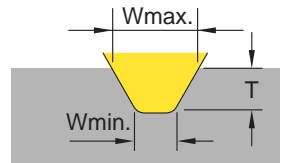

角度	訂購編號	鍍層	材質	尺寸	W		T				
					L	S	Re	Wmin.	Wmax.	Tmin.	Tmax.
60°	V06006T1W03	NC2032	TiAlN	K20F	6.35	2.0	---	0.25	1.1	0.05	0.8
		NC9036	DLC								
60°	V06006T1W06	NC2071	TiN	K20F	6.35	2.0	0.2	0.65	2.7	0.20	2.0
		NC2032	TiAlN								
		NC2035	ALDURA								
		NC9031	TiN								

▶ 刀桿 >>

- 熱縮型刀把 · 建議使用鎢鋼柄刀桿
- XL (100mm加長型) · 建議使用於鋁合金或軟材雕刻 · 不平衡量 < 0.6gm

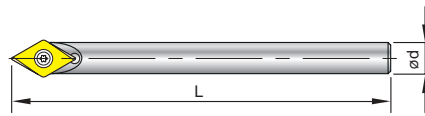
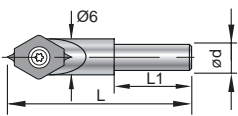

角度	訂購編號	Part No.	材質	Ød	L	L1	螺絲	扳手
60°	99619-V060-04	BC04-CT-V060	鋼	4	30	12	NS-22044 0.9Nm	NK-T7
	99619-V060-06	BC06-CT-V060	鋼		40	---		
	99619-V060-06L	BC06-CT-V060-60L	鎢鋼	6	60	---		
	99619-V060-06XL	BC06-CT-V060-06-100L	鎢鋼		100	---		
	99619-V060-08	BC08-CT-V060	鋼	8	60	---		

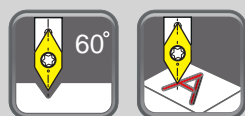

▶ 刀片 >>

- 細字微雕刻
- 4mm同柄徑設計
- 刀片有2個切削刃口

NC2032: • 泛用材種 · 適合所有鋼鐵

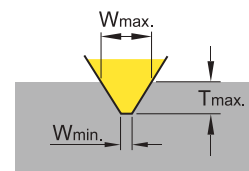

角度	訂購編號	鍍層	材質	尺寸	Wmin.	Wmax.	Tmax.
60°	W06004S101-NC2032	TiAlN	K20F		0.1	0.33	0.2
	W06004S102-NC2032				0.2	0.66	0.4
	W06004S103-NC2032				0.3	0.99	0.6

▶ 刀桿 >>

- 硬化鋼製作



角度	訂購編號	Part No.	Ød	L	螺絲	扳手
60°	99619-W060-04	BC04-CT-W060	4	40	NS-18037 0.6Nm	NK-T6
	99619-W060-06	BC06-CT-W060	6	40		

▶ 切削資料

S101	工件材質	主軸轉速 (r.p.m)	機台進給 (mm/rev.)	刀片材質	下刀深度 (mm)					
					1st	2nd	3rd	~	精細加工	
Tmax.: 0.2mm	P 低碳鋼 C<0.3%	8000 ~ 40000	0.002 ~ 0.015	NC2032	0.1	0.05	0.03	0.02	0.02	
	P 中碳鋼 C>0.3%	8000 ~ 40000	0.002 ~ 0.012	NC2032	0.1	0.05	0.03	0.02	0.02	
	M 合金鋼	8000 ~ 40000	0.002 ~ 0.010	NC2032	0.08	0.03	0.03	0.02	0.02	
	M 不鏽鋼	8000 ~ 40000	0.002 ~ 0.010	NC2032	0.08	0.03	0.03	0.02	0.02	
	K 鑄鐵	8000 ~ 40000	0.002 ~ 0.010	NC2032	0.1	0.05	0.03	0.02	0.02	
	N 鋁、非鐵金屬	8000 ~ 40000	0.002 ~ 0.020	NC2032	0.1	0.05	0.03	0.02	0.02	
S102	工件材質	主軸轉速 (r.p.m)	機台進給 (mm/rev.)	刀片材質	下刀深度 (mm)					
					1st	2nd	3rd	4th	~	精細加工
Tmax.: 0.4mm	P 低碳鋼 C<0.3%	8000 ~ 40000	0.002 ~ 0.015	NC2032	0.2	0.1	0.05	0.03	0.03	0.02
	P 中碳鋼 C>0.3%	8000 ~ 40000	0.002 ~ 0.012	NC2032	0.15	0.1	0.05	0.03	0.03	0.02
	M 合金鋼	8000 ~ 40000	0.002 ~ 0.010	NC2032	0.12	0.08	0.05	0.03	0.03	0.02
	M 不鏽鋼	8000 ~ 40000	0.002 ~ 0.010	NC2032	0.12	0.05	0.05	0.03	0.03	0.02
	K 鑄鐵	8000 ~ 40000	0.002 ~ 0.010	NC2032	0.15	0.1	0.05	0.03	0.03	0.02
	N 鋁、非鐵金屬	8000 ~ 40000	0.002 ~ 0.020	NC2032	0.2	0.1	0.1	0.05	0.03	0.02
S103	工件材質	主軸轉速 (r.p.m)	機台進給 (mm/rev.)	刀片材質	下刀深度 (mm)					
					1st	2nd	3rd	4th	~	精細加工
Tmax.: 0.6mm	P 低碳鋼 C<0.3%	8000 ~ 40000	0.002 ~ 0.015	NC2032	0.25	0.1	0.05	0.05	0.03	0.02
	P 中碳鋼 C>0.3%	8000 ~ 40000	0.002 ~ 0.012	NC2032	0.2	0.1	0.05	0.05	0.03	0.02
	M 合金鋼	8000 ~ 40000	0.002 ~ 0.010	NC2032	0.15	0.1	0.05	0.03	0.03	0.02
	M 不鏽鋼	8000 ~ 40000	0.002 ~ 0.010	NC2032	0.15	0.05	0.05	0.03	0.03	0.02
	K 鑄鐵	8000 ~ 40000	0.002 ~ 0.010	NC2032	0.2	0.1	0.05	0.05	0.03	0.02
	N 鋁、非鐵金屬	8000 ~ 40000	0.002 ~ 0.020	NC2032	0.3	0.1	0.1	0.05	0.03	0.02



▶ 刀片 >>

- 更換刀片不用重新設定刀具長度
- 刀片有4個切削刃口

60-NC40: • 高正角切削 · 60° 雕刻
泛用材種 · 適合鋼鐵 · 鑄鐵

NC40: • 泛用材種 · 適合鋼鐵

NC10: • 泛用材種 · 適合非鐵金屬 · 鑄鐵

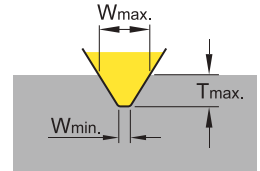

角度	訂購編號	鍍層	材質	尺寸	Wmin.	Wmax.	Tmax.		
								L	S
60°	60-NC40	TiN	K20F	8	2.38	0.2	1.1	0.8	
90°	N9MT080201W	NC40	TiN	K20F	8	2.38	0.2	2.0	0.9
90°	NC10	TiAlN	K20F	8	2.38	0.2	2.0	0.9	

▶ 刀桿 >>

- 使用車銑萬用鑽標準刀桿

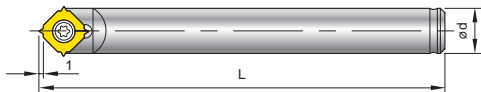

訂購編號	Part No.	Ød	L	螺絲	扳手
99616-10	BC10-CT-10	10	90	NS-30055 2.0 Nm	NK-T8
99616-10-3/8	BC3/8"-CT-10	3/8"	90		

▶ 切削資料

刻字加工: 刻字寬度=切削尺寸" d"
刻字深度=切削深度" T"

- 刀桿偏擺公差在0.01mm內。
- 注意: "d" 值僅用於計算轉速值。

雕刻

- $\alpha = 90^\circ$ 刀片, $d=2 \times T$
- $\alpha = 60^\circ$ 刀片, $d=1.73 \times T$

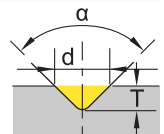







(Tmax.: 0.8 mm)

工件材質	主軸轉速 (r.p.m)	機台進給 (mm/rev.)	刀片材質	下刀深度 (mm)			
				1st	2nd	3rd	精細加工
P 鋼鐵	5000 ~ 20000	0.008 ~ 0.02	60-NC40, NC40	0.3	0.2	0.2	0.05
K 鑄鐵	5000 ~ 20000	0.008 ~ 0.02	60-NC40, NC10	0.3	0.2	0.2	0.05
N 非鐵金屬	5000 ~ 20000	0.008 ~ 0.02	NC10	0.3	0.2	0.2	0.05

性能

▶ 比較 >>

刀具				
切削資料		99619-V060-06 V06006T1W06-NC2071	刻字刀具	球型銑刀 0.4mm
工件材質		工具鋼 SKD 61 (JIS G 4404) 硬度: HRB92~93 (HB 200)		
主軸轉速	r.p.m.	10000	10000	10000
機台進給	mm/min.	100	100	300
切削深度	Ap	0.2 mm	0.2 mm	0.05 mm, 四倍切削深度0.2 mm
底部粗糙度 Ra		0.36 μm	0.83 μm	0.46 μm
更換及重新定位		無需	需	需
刀具壽命		長	短	短
使用 Alicona IFM 系統 量測結果				

刀具		99619-V060-06 V06006T1W06-NC2071	99619-V060-06 V06006T1W06-NC2071	99619-V060-06 V06006T1W06-NC2035
切削資料		P SKD 51	M SS	H SKD 61 (HRC50)
工件材質				
主軸轉速	r.p.m.	10000	10000	10000
機台進給	mm/min.	300	300	100
切削深度	Ap	0.1 mm	0.35 mm	0.2 mm
更換及重新定位		無需	無需	無需
刀具壽命		24 min.(1440 sec.)	7.2 meters	3.5 meters

▶ 小提醒 >>

V045與V060刻字刀具有耐磨性及良好的斷屑性，能加工不鏽鋼等難切削材質；銳利刃口防止毛邊。刻字刀半徑0.2mm (0.08") 超銳利刃口，加工精度細緻。字幅寬度0.45mm (0.017")。取代傳統球銑刀，最佳的雕刻刀具選擇。

零件



奢侈品



模具工業& 高附加價值產品

產品



3

雕刻刀

切削資料

► 使用前請注意下列事項

- 1 刀把選擇**
熱縮刀把 · 油壓刀把 · 高精度筒夾刀把均可適用
- 2 刀把的動平衡**
動平衡要求G6.3 / 10,000R.P.M
- 3 Z軸進給**
Z軸進給需降低50%
- 4 刀把偏擺**
夾持後偏擺應低於0.01mm
- 5 建議使用扭力扳手**
鎖緊扭力0.9 Nm

6 切削液與冷卻

切削液 / 切削油

P 鋼 **M** 不鏽鋼
S 鈦合金 **H** 熱處理鋼

切削油

N 非鐵金屬

吹氣冷卻

K 鑄鐵

3

雕刻刀

► 刀片安裝注意事項

- 刀座端刀片必需緊密貼合

將刀片平整放入刀片座

• 第一步

將刀片壓緊刀片座

• 第二步

確實鎖緊螺絲

• 第三步

切削資料 >> 0.1mm 微鑽孔

► X060A90W010R

工件材質	主軸轉速(r.p.m)	機台進給 (mm/rev.)	刀片材質
P 低碳鋼 C<0.3%	8000 ~ 40000	0.002 ~ 0.012	NC2032
中碳鋼 C>0.3%		0.002 ~ 0.010	NC2032
合金鋼		0.002 ~ 0.010	NC2032, NC2035
M 不鏽鋼		0.002 ~ 0.008	NC2032
K 鑄鐵		0.002 ~ 0.010	NC2032
N 鋁		0.002 ~ 0.015	XP9001
銅 · 黃銅		0.002 ~ 0.015	XP9001
H 熱處理 HRC56度		0.002 ~ 0.006	NC2035

► X060A120W010R / X060A142W010R

工件材質	主軸轉速(r.p.m)	機台進給 (mm/rev.)	刀片材質
P 低碳鋼 C<0.3%	8000 ~ 40000	0.001 ~ 0.015	NC2032
中碳鋼 C>0.3%		0.001 ~ 0.012	NC2032
合金鋼		0.001 ~ 0.010	NC2032
M 不鏽鋼		0.001 ~ 0.010	NC2032
K 鑄鐵		0.001 ~ 0.010	NC2032

切削資料 >> X060 雕刻系列

▶ X060A30W020R / X060A30R020

(Tmax. : 0.6mm)

工件材質	主軸轉速 r.p.m	機台進給 (mm/rev.)		刀片材質	下刀深度 (mm)					
		圓鼻尖	圓球尖形		1st	2nd	3rd	4th	5th ~	精細加工
P 低碳鋼 C<0.3%	8000 ~ 40000	0.001 ~ 0.010	0.002 ~ 0.015	NC2032	0.2	0.1	0.05	0.05	0.05	0.02
中碳鋼 C>0.3%		0.001 ~ 0.008	0.002 ~ 0.012	NC2032	0.15	0.1	0.05	0.05	0.05	0.02
合金鋼		0.001 ~ 0.006	0.002 ~ 0.010	NC2032, NC2035	0.15	0.1	0.05	0.05	0.03	0.02
M 不鏽鋼		0.001 ~ 0.006	0.002 ~ 0.010	NC2032	0.1	0.05	0.05	0.03	0.03	0.02
K 鑄鐵		0.001 ~ 0.006	0.002 ~ 0.010	NC2032	0.15	0.1	0.05	0.05	0.03	0.02
N 鋁		0.001 ~ 0.012	0.002 ~ 0.020	XP9001	0.2	0.1	0.1	0.05	0.05	0.02
銅·黃銅		0.001 ~ 0.012	0.002 ~ 0.020	XP9001	0.2	0.1	0.1	0.05	0.05	0.02
H 熱處理 HRC56度		0.001 ~ 0.005	0.002 ~ 0.006	NC2035	0.1	0.05	0.03	0.03	0.02	0.01

▶ X060A45W020R / X060A45R020

(Tmax. : 0.8mm)

工件材質	主軸轉速 r.p.m	機台進給 (mm/rev.)		刀片材質	下刀深度 (mm)					
		圓鼻尖	圓球尖形		1st	2nd	3rd	4th	5th ~	精細加工
P 低碳鋼 C<0.3%	8000 ~ 40000	0.002 ~ 0.012	0.002 ~ 0.015	NC2032	0.3	0.2	0.1	0.05	0.05	0.03
中碳鋼 C>0.3%		0.002 ~ 0.010	0.002 ~ 0.012	NC2032	0.25	0.15	0.1	0.05	0.05	0.03
合金鋼		0.002 ~ 0.010	0.002 ~ 0.010	NC2032, NC2035	0.2	0.1	0.05	0.05	0.05	0.03
M 不鏽鋼		0.002 ~ 0.008	0.002 ~ 0.010	NC2032	0.2	0.1	0.05	0.05	0.05	0.03
K 鑄鐵		0.002 ~ 0.010	0.002 ~ 0.010	NC2032	0.2	0.1	0.1	0.05	0.05	0.03
N 鋁		0.002 ~ 0.015	0.002 ~ 0.020	XP9001	0.3	0.2	0.1	0.1	0.05	0.03
銅·黃銅		0.002 ~ 0.015	0.002 ~ 0.020	XP9001	0.3	0.2	0.1	0.1	0.05	0.03
H 熱處理 HRC56度		0.002 ~ 0.006	0.002 ~ 0.006	NC2035	0.15	0.1	0.05	0.05	0.03	0.02

▶ X060A60W020R / X060A60R020

(Tmax. : 1.0mm)

工件材質	主軸轉速 r.p.m	機台進給 (mm/rev.)		刀片材質	下刀深度 (mm)					
		圓鼻尖	圓球尖形		1st	2nd	3rd	4th	5th ~	精細加工
P 低碳鋼 C<0.3%	8000 ~ 40000	0.002 ~ 0.012	0.002 ~ 0.015	NC2032	0.3	0.2	0.1	0.1	0.05	0.03
中碳鋼 C>0.3%		0.002 ~ 0.010	0.002 ~ 0.012	NC2032	0.3	0.2	0.1	0.1	0.05	0.03
合金鋼		0.002 ~ 0.010	0.002 ~ 0.010	NC2032, NC2035	0.3	0.1	0.1	0.05	0.05	0.03
M 不鏽鋼		0.002 ~ 0.008	0.002 ~ 0.010	NC2032	0.2	0.1	0.1	0.05	0.05	0.03
K 鑄鐵		0.002 ~ 0.010	0.002 ~ 0.010	NC2032	0.3	0.1	0.1	0.05	0.05	0.03
N 鋁		0.002 ~ 0.015	0.002 ~ 0.020	XP9001	0.3	0.2	0.1	0.1	0.05	0.03
銅·黃銅		0.002 ~ 0.015	0.002 ~ 0.020	XP9001	0.3	0.2	0.1	0.1	0.05	0.03
H 熱處理 HRC56度		0.002 ~ 0.006	0.002 ~ 0.006	NC2035	0.2	0.1	0.05	0.05	0.03	0.02

▶ X060A90W020R

(Tmax. : 1.0mm)

工件材質	主軸轉速 r.p.m	機台進給 (mm/rev.)	刀片材質	下刀深度 (mm)					
				1st	2nd	3rd	4th	5th ~	精細加工
P 低碳鋼 C<0.3%	8000 ~ 40000	0.002 ~ 0.015	NC2032	0.35	0.25	0.15	0.1	0.05	0.03
中碳鋼 C>0.3%		0.002 ~ 0.012	NC2032	0.3	0.2	0.1	0.1	0.05	0.03
合金鋼		0.002 ~ 0.010	NC2032, NC2035	0.3	0.1	0.1	0.05	0.05	0.03
M 不鏽鋼		0.002 ~ 0.010	NC2032	0.2	0.1	0.1	0.05	0.05	0.03
K 鑄鐵		0.002 ~ 0.010	NC2032	0.3	0.1	0.1	0.05	0.05	0.03
N 鋁		0.002 ~ 0.020	XP9001	0.4	0.3	0.2	0.1	0.05	0.03
銅·黃銅		0.002 ~ 0.020	XP9001	0.4	0.3	0.2	0.1	0.05	0.03
H 熱處理 HRC56度		0.002 ~ 0.006	NC2035	0.2	0.1	0.05	0.05	0.03	0.02

3

雕刻刀

切削資料

▶ 切削深度及字寬參考圖

- 圖表使用，首先選擇需要字寬W（垂直軸），再選擇刻字的角度（45°或60°）參考線，取得參考點後切削深度（T），向下取得切削所需深度
- 隨垂直軸線決定切削深度

▶ V045/V060 T1W06 >>

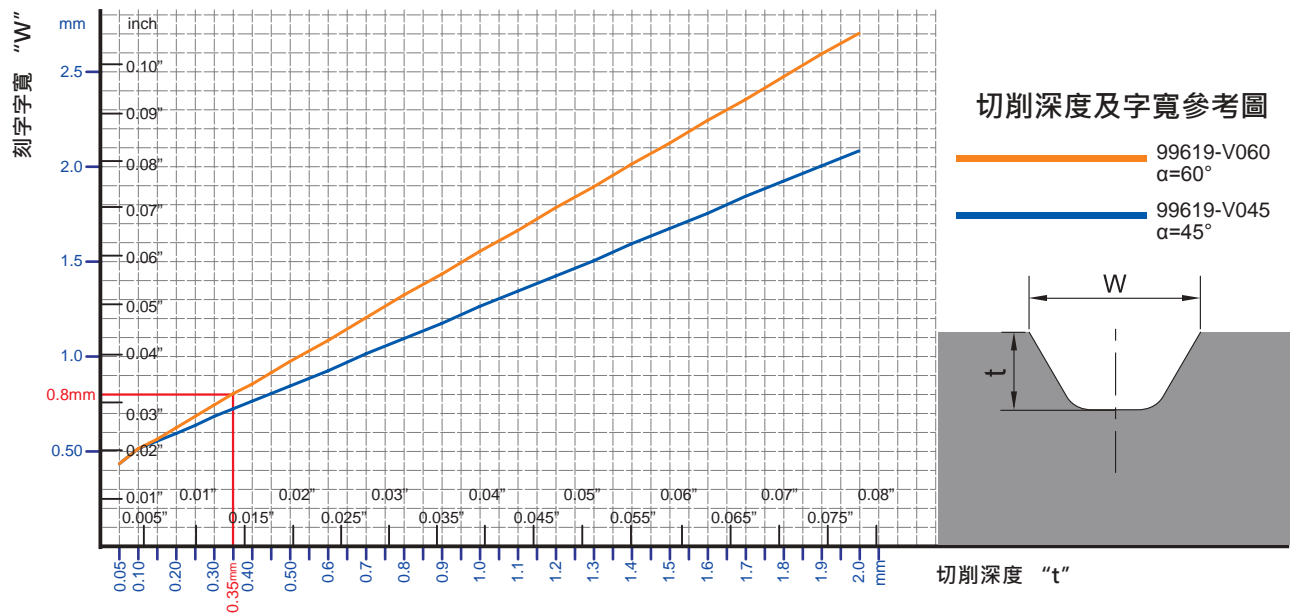

工件材質		主軸轉速 r.p.m	機台進給 (mm/rev.)	刀片材質
P	碳鋼	5000~40000	0.008~0.05	NC2071,NC2032
	合金鋼	5000~40000	0.008~0.03	NC2032,NC2071
M	不鏽鋼	5000~40000	0.008~0.05	NC2071,NC9031
K	鑄鐵	5000~40000	0.008~0.03	NC2032
N	鋁、非鐵金屬	5000~40000	0.008~0.08	NC2071,NC9031
H	熱處理 HRC56度	6000~35000	0.003~0.01	NC2035

下刀深度 T_{max.}:2mm

工件材質		Ap	1st	2nd	3rd	4th	5th	6th	~	精細加工
P	碳鋼		0.8	0.6	0.3	0.2	0.1	~	~	0.05
	合金鋼		0.5	0.4	0.3	0.3	0.2	0.2	0.1	0.05
M	不鏽鋼		0.5	0.4	0.3	0.3	0.2	0.2	0.1	0.05
K	鑄鐵		0.8	0.6	0.3	0.2	0.1	~	~	0.05
N	鋁、非鐵金屬		1.0	0.8	0.2	~	~	~	~	0.05
H	熱處理 HRC56度		0.2	0.2	0.15	0.15	0.1	0.1	0.1	0.05

3

雕刻刀

切削資料

▶ V060 T1W03 >>

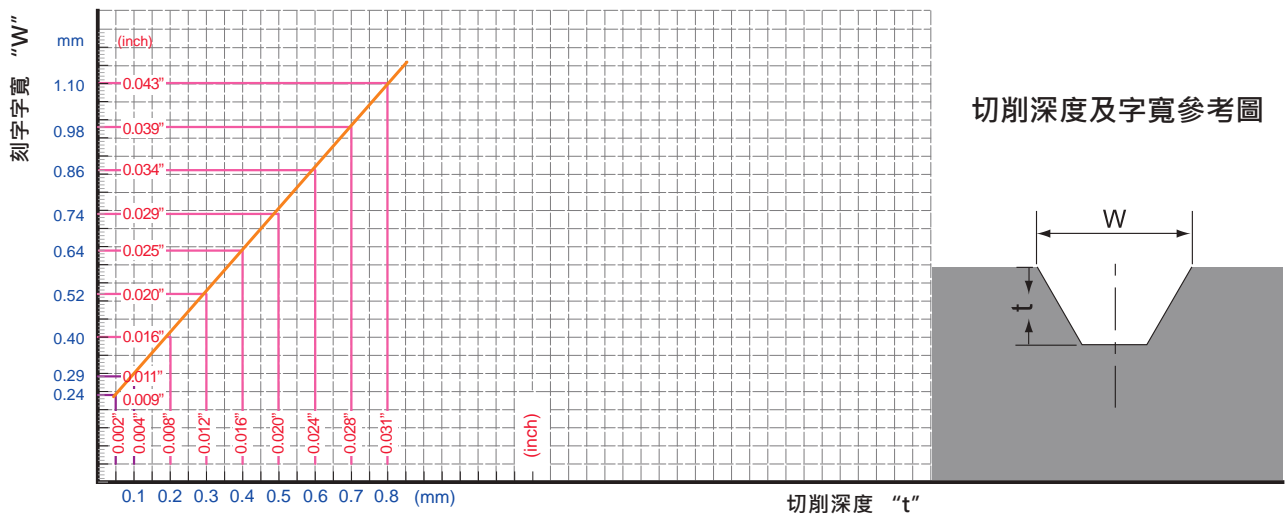

工件材質		主軸轉速 r.p.m	機台進給 (mm/rev.)	刀片材質
P	低碳鋼 C<0.3%	8000 ~ 40000	0.005 ~ 0.010	NC2032
	中碳鋼 C>0.3%	8000 ~ 40000	0.005 ~ 0.015	NC2032
	合金鋼	6000 ~ 35000	0.005 ~ 0.010	NC2032
M	不鏽鋼	8000 ~ 35000	0.003 ~ 0.010	NC9036
K	鑄鐵	6000 ~ 35000	0.005 ~ 0.015	NC2032
N	鋁	8000 ~ 40000	0.005 ~ 0.015	NC9036
	銅·黃銅	8000 ~ 40000	0.005 ~ 0.010	NC9036
S	鈦	6000 ~ 15000	0.003 ~ 0.010	NC9036

下刀深度 T_{max.}:0.8mm

工件材質		Ap	1st	2nd	3rd	4th	5th	~	精細加工
P	低碳鋼 C<0.3%		0.3	0.2	0.1	0.1	0.05	0.05	0.03
	中碳鋼 C>0.3%		0.3	0.2	0.1	0.1	0.05	0.05	0.03
	合金鋼		0.3	0.1	0.1	0.05	0.05	0.05	0.03
M	不鏽鋼		0.2	0.1	0.1	0.1	0.05	0.05	0.03
K	鑄鐵		0.2	0.1	0.1	0.1	0.05	0.05	0.03
N	鋁		0.2	0.1	0.1	0.1	0.05	0.05	0.03
	銅·黃銅		0.2	0.1	0.1	0.1	0.05	0.05	0.03
S	鈦		0.2	0.1	0.1	0.1	0.05	0.05	0.03

3

雕刻刀



NC 去毛邊刀 >>>

60° & 90°

適用於微小去毛邊

P M K N

▶ 捨棄式、全研磨刀片。

- 在CNC工具機上實現高速、高進給的去毛邊。
- 使去除毛邊後的零件外觀均勻。



Features >

X060A..T3		
3 刃刀片	2個切削刃口	
	60°	90°
<ul style="list-style-type: none">• 適用於 < 90° 的內角。• 更大的排屑空間。	<p>1 2 30° Tmax. 0.9mm Minimum 0.1mm 0.5</p>	<p>1 2 45° Tmax. 0.9mm Minimum 0.1mm 0.5</p>

X060A..T6		
6 刃刀片	1個切削刃口	
	60°	90°
<ul style="list-style-type: none">• 適合簡單的輪廓。• 去毛刺快速、省時。	<p>1 30° Tmax. 1.8mm Minimum 0.1mm 0.5</p>	<p>1 45° Tmax. 1.5mm Minimum 0.5mm</p>

NC去毛邊刀

美國專利認證 US 9,718,137 B2

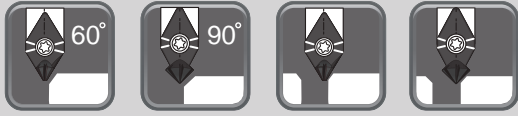

▶ 刀片 >>

- 最小倒角直徑 $\varnothing 0.5\text{mm}$
- 3刃雙頭毛邊刀 · 3倍高速進給 · 1個刀片2個切削角 · 具有極高的經濟效益
- 6刃單頭毛邊刀 · 6倍高速進給 · 適合大量生產

- XP9001: • 適用於非鐵金屬 · 鋁合金 · 銅合金 · 塑膠 · 壓克力等軟性材質。
 NC2032: • 適用鋼鐵 · 鑄鐵 · 硬化鋼 < HRC50。

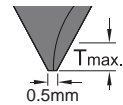

刃數	角度	訂購編號	鍍層	材質	尺寸	尺寸		Tmin.	Tmax.
						L	S		
3	60°	X060A60T3-XP9001	Uncoated	K20F		6	2.8	0.1	0.9
		X060A60T3-NC2032	TiAlN						
	90°	X060A90T3-XP9001	Uncoated						
		X060A90T3-NC2032	TiAlN						
6	60°	X060A60T6-NC2032	TiAlN	K20F		6	2.0	0.1	1.8
	90°	X060A90T6-NC2032						0.5	1.5

▶ 刀桿 >>

- 共用X060所有刀片
- 可裝置6刃去毛邊刀片



訂購編號	Part No.	材質	Ød	L	螺絲	扳手
99619-X060-06	BC06-CT-X060	鋼	6	40		
99619-X060-06L	BC06-CT-X060-60L	鎢鋼	6	60		
99619-X060-06LS	BC06-CT-X060-60LS	鋼	6	60		
99619-X060-06XL	BC06-CT-X060-100L	鎢鋼	6	100		
99619-X060-08	BC08-CT-X060	鋼	8	60	NS-22044 0.9Nm	NK-T7

▶ 切削資料 >>

工件材質	主軸轉速 (r.p.m.)	Feed Rate (mm / tooth)	刀片材質
P 低碳鋼 C<0.3%	8000~40000	0.005-0.05	NC2032
合金鋼	6000~35000	0.005-0.04	
M 不鏽鋼	6000~25000	0.005-0.03	
K 鑄鐵	6000~35000	0.005-0.03	XP9001
N 鋁 · 非鐵金屬材質	8000~40000	0.005-0.05	

4

去毛邊刀

捨棄式去毛邊輪 >>>

55°, 60°, 90° 刀片和 T形槽刀, 鳩尾槽刀

多種應用刀片。專用於 10mm 以下狹窄空間的捨棄式去毛邊刀。

P M K N H

▶ 1支刀桿可選用多種刀片

▶ 6個切削刃

• 增加進給速度，優化性能並縮短加工時間。

▶ 加工孔徑最小Ø5(mm)



90° 刀片

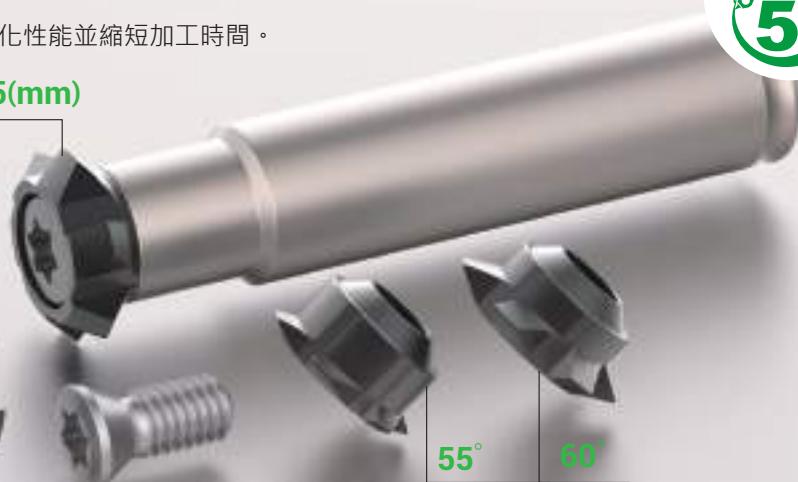

55°

60°

Features >>>

▶ 55° / 60° 捨棄式去毛邊輪

- M6尺寸，世界最迷你捨棄式去毛邊輪。
- 也適用於銑牙加工。
- 6個切削刃。
- 特殊的刀片幾何形狀和 Nine9 鎖緊結構，提供了高精度和準確的位置。
- 最小的刀片Ø5.0可以進行M6xP0.75內螺紋和去毛邊。
- 加工螺紋時，可藉由 NC程式完成不同的牙距。
例如：Ø10.0mm刀片可以處理外螺紋，螺距從P1.25到P2.0mm，節省您的刀具庫存。

▶ 90° 捨棄式去毛邊輪

- 正反倒角一次完成，也可用於銑溝槽。
- 世界最迷你捨棄式去毛邊輪。最小去毛邊孔徑從 Ø3.9 ~ Ø10mm。
- 6個切削刃。

▶ T形槽刀以及鳩尾槽刀

- 槽寬1mm。



Applications

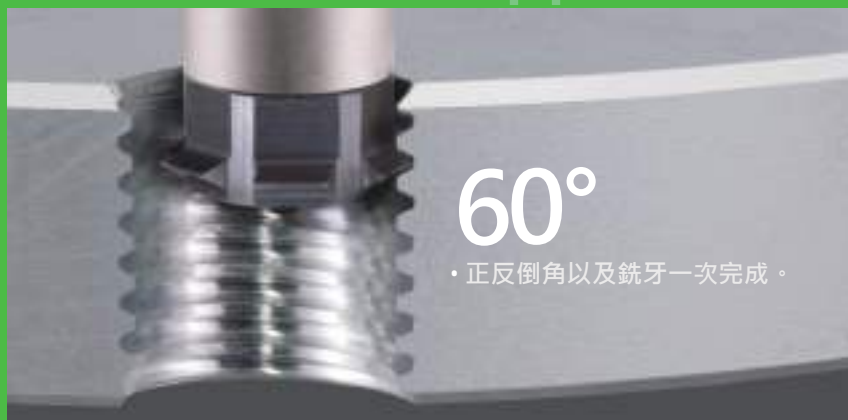

60°

• 正反倒角以及銑牙一次完成 •



90°

• 正反倒角 •
• 最小刀頭尺寸 Ø5mm •

C0.2

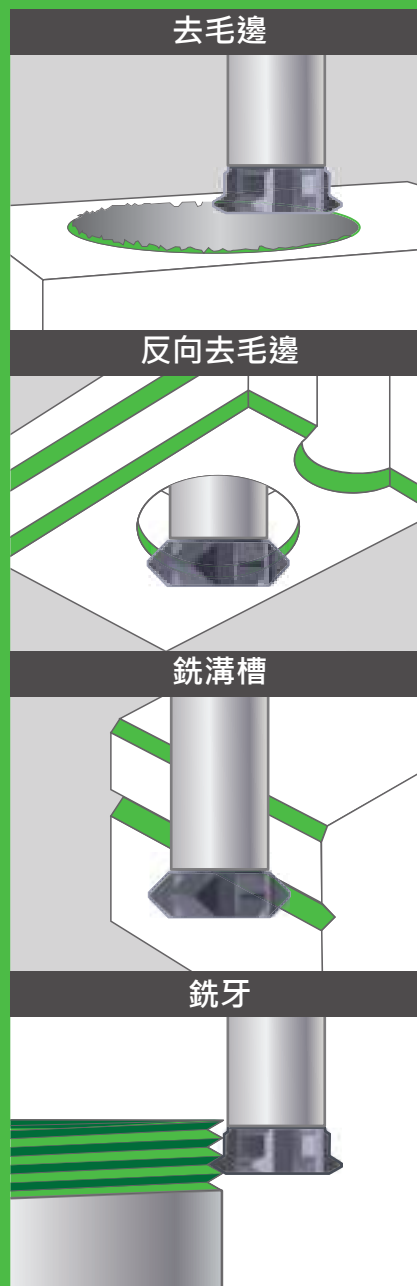

去毛邊

反向去毛邊

銑溝槽

銑牙

- “
- 專用於 10mm 以下狹窄空間的捨棄式去毛邊刀
 - 6個切削刃，高進給，可切削 HRC硬度60度工件 ”

4

捨棄式去毛邊輪

捨棄式去毛邊輪 55°, 60° & 90°

美國專利認證
US 11,583,941 B2

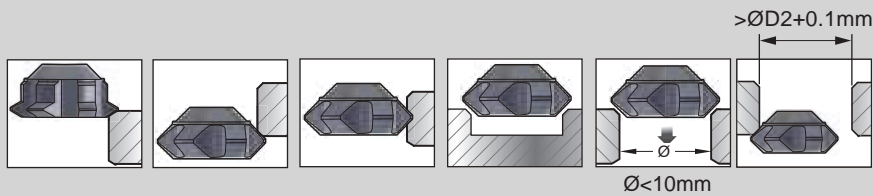

6個切削刃

▶ 刀片 >>

NC2032: • TiAIN 鍍層，刀片壽命長。適用鋼鐵，鑄鐵，硬化鋼 < 60 HRC。

XP9000: • 適用非鐵金屬、鋁合金、銅合金、塑膠、壓克力。

▶ 55° 毛邊輪

- 6個切削刃，切削進給快，刃口全研磨處理，不會產生2次毛邊，輕鬆達成微細外螺牙、內螺牙。



訂購編號	鍍層	材質	ØD1	ØD2	L	LC1	LC2	LC3	LC4	S	銑牙		Plunge 0.1C		
											TPI	最小孔	最大孔		
R05507-06512-32	TiAIN	K20F		5.32	6.56	0.12	0.03	0.35	0.47	0.79	3.25	28	5.5	6.3	
R05507-06512-00	Uncoated			6.92	10.0	0.18	0.03	0.83	1.01	1.82	4.6	19 - 14	7.1	9.8	
R05510-10018-32	TiAIN														
R05510-10018-00	Uncoated														

▶ 60° 毛邊輪

- M6尺寸，世界最迷你捨棄式去毛邊輪。
- 6個切削刃，切削進給快，刃口全研磨處理，不會產生2次毛邊，輕鬆達成微細外螺牙、內螺牙。



訂購編號	鍍層	材質	ØD1	ØD2	L	LC1	LC2	LC3	LC4	S	銑牙		Plunge 0.1C														
											mm	TPI	最小孔	最大孔													
R06005-05006-32	TiAIN	K20F		3.9	5.0	0.06	0.03	0.34	0.40	0.72	2.45	0.7 - 0.75	32 - 28	4.1	4.8												
R06005-05006-00	Uncoated																										
R06005-05010-32	TiAIN															3.9	5.0	0.1	0.03	0.34	0.44	0.76	2.45	0.8 - 1.0	28 - 24	4.1	4.8
R06005-05010-00	Uncoated																										
R06007-06810-32	TiAIN															5.5	6.8	0.1	0.03	0.40	0.50	0.87	3.25	0.8 - 1.25	28 - 20	5.7	6.6
R06007-06810-00	Uncoated																										
R06010-08510-32	TiAIN															6.9	8.5	0.1	0.03	0.49	0.59	1.05	4.60	1.0 - 1.5	24 - 18	7.1	8.3
R06010-08510-00	Uncoated																										
R06010-10010-32	TiAIN															6.9	10.0	0.1	0.03	0.92	1.02	1.91	4.60	1.0 - 2.0	24 - 13	7.1	9.8
R06010-10010-00	Uncoated																										

4

捨棄式去毛邊輪

捨棄式去毛邊輪 55°, 60° & 90°

美國專利認證
US 11,583,941 B2

▶ 90° 毛邊輪

- 正反倒角一次完成



訂購編號	鍍層	材質	ØD1	ØD2	L	LC1	LC2	LC3	LC4	S	Plunge 0.1C			
											最小孔	最大孔		
R09005-05060-32	TiAIN	K20F		3.9	5.0	0.6	0.05	0.6	1.2	1.75	2.45	4.1	4.8	
R09005-05060-00	Uncoated			5.1	7.0	0.2	0.05	1.0	1.2	2.15	3.25	5.3	6.8	
R09007-07020-32	TiAIN			7.2	10.0	0.1	0.05	1.45	1.55	2.95	4.60	7.4	9.8	
R09007-07020-00	Uncoated													
R09010-10010-32	TiAIN													
R09010-10010-00	Uncoated													

4

捨棄式去毛邊輪

▶ T形槽刀



訂購編號	鍍層	材質	ØD1	ØD2	L	LC1	LC2	S	
R00010-10010-32	TiAIN	K20F		8.21	10	1	0.1	1.1	4.6
R00010-10010-00	Uncoated								

▶ 鳩尾槽刀



訂購編號	鍍層	材質	ØD1	ØD2	L	A	R	S	
R04510-100TR02-32	TiAIN	K20F		10	8.1	1.23	45°	0.2	4.6
R04510-100TR02-00	Uncoated								

捨棄式去毛邊輪刀桿 55° / 60° / 90° 共用



► 硬化鋼刀桿 >>

- 硬化鋼製作
- 55°, 60°, 90° 刀片和 T形槽刀, 鳩尾槽刀共用刀桿

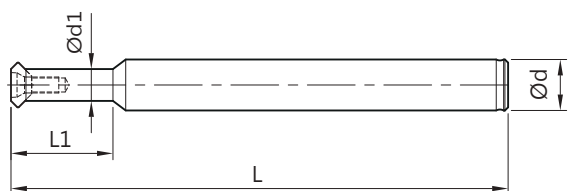

訂購編號	Part No.	Ød	Ød1	L1	L	刀片類型	螺絲	扳手
99626-CR05-05-031	BC05-CR05-031	5	3.5	6	31			
99626-CR05-08-076	BC08-CR05-076	8	3.5	12	76	Rxxx05	NS-20045 0.6Nm	NK-T6
99626-CR05-05-043	BC05-CR05-043	5	3.5	18	43			
99626-CR07-06-036	BC06-CR07-036	6	5	8	36			
99626-CR07-08-078	BC08-CR07-078	8	5	16	78	Rxxx07	NS-25060 0.9Nm	NK-T7
99626-CR07-06-052	BC06-CR07-052	6	5	24	52			
99626-CR10-08-040	BC08-CR10-040	8	6.8	10	40			
99626-CR10-08-082	BC08-CR10-082	8	6.8	20	82	Rxxx10	NS-35080 2.5Nm	NK-T15
99626-CR10-08-070	BC08-CR10-070	8	6.8	30	70			

► 抗震刀桿 >>

- 鎢鋼製作
- 針對長懸深 須抗震的加工，提供更好的加工穩定度及刀具壽命
- 55°, 60°, 90° 刀片和 T形槽刀, 鳩尾槽刀共用刀桿

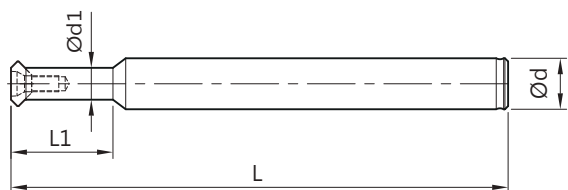

訂購編號	Part No.	Ød	Ød1	L1	L	刀片類型	螺絲	扳手
99626-CR10-08-068-W	BC08-CR10-068-083W	8	6.8	30.4	87			
99626-CR10-08-080-W	BC08-CR10-080-083W	8	8	-	87	Rxxx10	NS-35080 2.5Nm	NK-T15
99626-CR10-10-095-W	BC10-CR10-095-108W	10	9.5	12	112			

切削資料

▶ 60° & 90° 去毛邊輪- 去毛邊加工

	工件材質	切削速率 (Vc m/min.)	進給速率 (mm / tooth)	刀片鍍層
P	碳鋼	120 ~ 250	0.005 ~ 0.12	NC2032
	合金鋼	100 ~ 200	0.005 ~ 0.10	NC2032
M	不鏽鋼	60 ~ 150	0.005 ~ 0.10	NC2032
K	鑄鐵	80 ~ 180	0.005 ~ 0.10	NC2032
N	鋁、非鐵金屬	150 ~ 500	0.005 ~ 0.15	XP9000
H	熱處理 < 60 HRC	40 ~ 100	0.005 ~ 0.05	NC2032

▶ 55° & 60° 去毛邊輪- 銑牙加工

	工件材質	切削速率 (Vc m/min.)	進給速率 (mm / tooth)	刀片鍍層
P	碳鋼	80 ~ 150	0.002 ~ 0.013	NC2032
	合金鋼	60 ~ 120	0.002 ~ 0.01	NC2032
M	不鏽鋼	50 ~ 100	0.002 ~ 0.01	NC2032
K	鑄鐵	50 ~ 100	0.002 ~ 0.01	NC2032
N	鋁、非鐵金屬	100 ~ 300	0.002 ~ 0.013	XP9000
H	熱處理 < 60 HRC	30 ~ 60	0.002 ~ 0.008	NC2032

4



特殊靠模倒角刀

讓鍛/鑄造工件倒角外觀一致



特殊靠模刀具結構：

- 一支浮動夾頭 ·
- 一支刀桿 ·
- 一片i-Center刀片 ·
- 一個軸承培林 ·

特殊品
歡迎洽詢



鍛/鑄造工件因為環境及材料因素，造成工件外觀尺寸有大有小，我們設計特殊靠模刀具結構，讓鍛造工件倒角外觀一致，視覺完全看不出差異。

捨棄式去毛邊輪



密齒倒角刀 >>>

45° 正反倒角

耐久密齒倒角刀是可正面倒角和反面倒角的特殊設計，刀片可作高速度加工，多刃密齒可大幅增加進給率，縮減倒角加工時間



▶ 高性價比

- 刀片有4個切削刃口
- 刀片壽命長



Features >>>

▶ 優異的重現性

- 最小的倒角尺寸 $\varnothing 7\text{mm}$
- 雙角度倒角刀片，採高速度切削刃口和耐磨鍍層
- 最密集的刀刃數設計，最高倒角進給率



▶ 應用

- 90° 皿頭孔和45° 倒角
- 多功能加工可作皿頭孔，圓形倒角，反向倒角刀，銑平面

- ▶ 正向倒角和反向倒角一次，加工完成，節省加工時間



Applications



4

“

- 超高速度與高進給，倒角加工效率最高
- 密齒倒角刀可產生4倍至10倍的加工效率

”

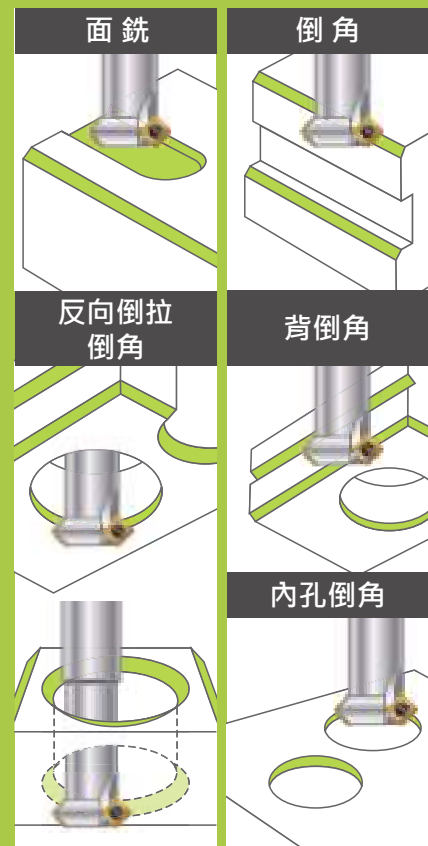

密齒倒角刀

倒拉倒角刀

▶ 特性 >>

- 特殊双角度的刀片設計，耐磨耗的鍍層，刀片可高速、高進給切削
- 刀片有4個切削刃口
- 特殊刃口設計，刀片壽命長

▶ 刀片 >>

- NC2032:** • AITiN鍍層，刀片壽命長
• 適用鋼鐵，鑄鐵，硬化鋼 < HRC56
• 刀片有4個切削刃口
- NC9071:** • TiN鍍層，銳利刃口加工表面優異
• 適合非鐵金屬，鋁合金，銅合金，不鏽鋼
• 刀片有4個切削刃口

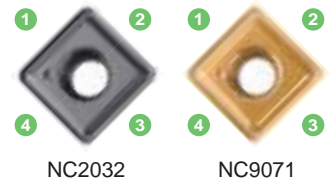

訂購編號	鍍層	材質	尺寸			螺絲	扳手
			L	S	Re		
N9GX04T002	NC2032	AITiN	4.0	1.8	0.2	NS-18037 0.6Nm	NK-T6
	NC9071	TiN					
N9GX060204	NC2032	AITiN	6.35	2.38	0.4	NS-22055 0.9Nm	NK-T7
	NC9071	TiN					
N9GX090308	NC2032	AITiN	9.52	3.18	0.8	NS-30072 2.0Nm	NK-T9
	NC9071	TiN					

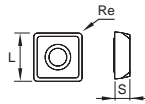

4

密齒倒角刀

▶ 刀桿_ 99616-C02, C04, C06 >>

- 硬化鋼製作
- 特別加工的柄部，增加刀具強度
- 柄徑公差達h6

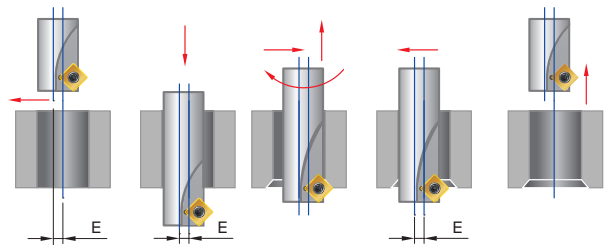
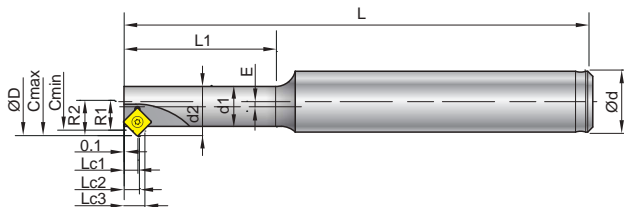

訂購編號	Part No.	Cmin ø	Cmax ø	ød	ød1	ød2	øD	R1	R2	L	L1	Lc1	Lc2	Lc3	E	Øz	刀片 螺絲/扳手
99616-C02	BC10-C02-80	6.8	8.8	10	5.25	6.5	9	3.4	4.4	80	20	2.56	2.93	3.93	1.25	1	N9GX04T002
99616-C04	BC12-C04-100	8.5	10.8	12	6.45	8	11.1	4.25	5.4	100	25	2.51	2.98	4.13	1.55	1	NS-18037 0.6Nm / NK-T6
99616-C06	BC12-C06-100	10.26	13.2	12	7.88	9.75	13.5	5.13	6.6	100	30	2.51	2.98	4.45	1.88	1	

▶ 刀桿_ 99616-C10~99616-C52 >>

- 硬化鋼製作
- 柄徑公差達h6

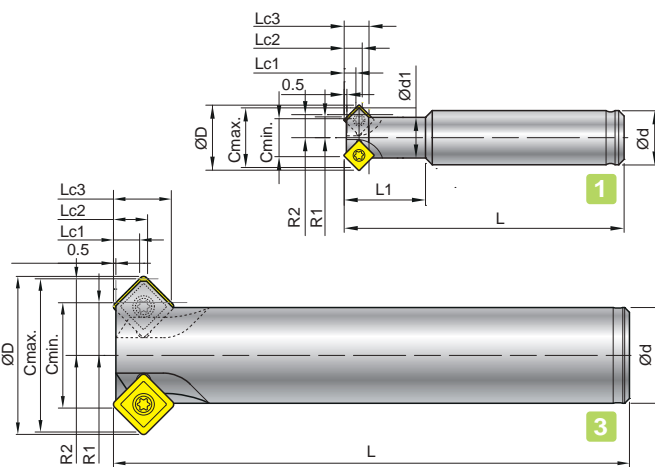
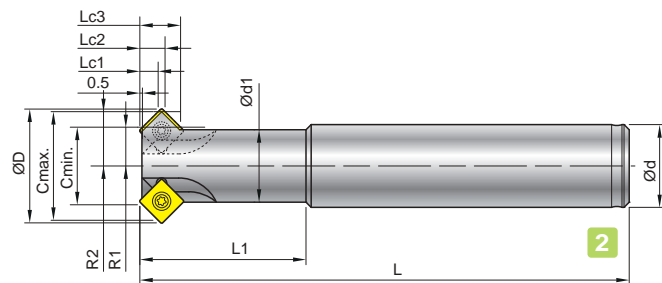

圖示	訂購編號	Part No.	Cmin ø	Cmax ø	ød	ød1	øD	R1	R2	L	L1	Lc1	Lc2	Lc3	z	刀片 螺絲/扳手
1	99616-C10	BC10-C07-60	7	11	10	7.5	12	3.5	5.5	60	15	2.6	2.9	4.6	2	N9GX04T002 NS-18037 0.6Nm NK-T6
	99616-C20	BC12-C11-100	11	16	12	9.6	16.15	5.5	8	100	25	2.6	2.9	5.0	4	N9GX060204 NS-22055 0.9Nm NK-T7
2	99616-C30	BC16-C15-120	15	21	16	14	22	7.5	10.5	120	40	3.5	4.9	7.9	4	N9GX060204 NS-22055 0.9Nm NK-T7
	99616-C40	BC20-C19-130	19	25	20	18	26	9.5	12.5	130	50	3.5	4.9	7.9	4	N9GX090308 NS-30072 2.0Nm NK-T9
3	99616-C50	BC20-C22-130	22	32	20	--	33	11	16	130	--	5.5	7.1	12.1	4	N9GX090308 NS-30072 2.0Nm NK-T9
2	99616-C52	BC25-C22-180	22	32	25	20	33	11	16	180	80	5.5	7.1	12.1	4	N9GX090308 NS-30072 2.0Nm NK-T9

▶ 鎖牙型刀頭_ 99616-CM16~99616-CM29 >>

- 標準接桿可適用
- 適用延長桿，請詳見9-189頁

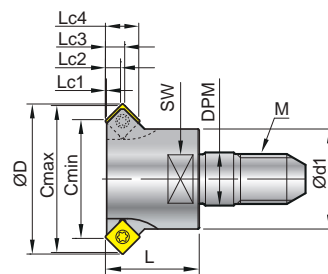

訂購編號	Part No.	Cmin ø	Cmax ø	øD	M	SW	ød1	DPM	L	Lc1	Lc2	Lc3	Lc4	z	刀片 螺絲/扳手
99616-CM16-M05	M05-CM16	11	16	16.15	M5	8	10	5.5	15	0.09	2.59	2.9	5.4	3	N9GX04T002 NS-18037 0.6Nm NK-T6
99616-CM20-M06	M06-CM20	15	20	20.15	M6	11	12	6.5	16	0.09	2.59	2.9	5.4	4	N9GX060204 NS-22055 0.9Nm NK-T7
99616-CM23-M08	M08-CM23	19	23.5	24	M8	14	16	8.5	19	0.16	2.41	3.08	5.33	4	N9GX060204 NS-22055 0.9Nm NK-T7
99616-CM29-M10	M10-CM29	23	29	30	M10	18	20	10.5	17	0.54	3.54	4.87	7.87	4	N9GX060204 NS-22055 0.9Nm NK-T7

▶ 套裝組合 >>

圖示	訂購編號	含刀片	含刀桿	內容
1	99616-C1020-32	N9GX04T002-NC2032	99616-C10 +	2支刀桿 + 10片刀片 + 1支扳手
	99616-C1020-71	N9GX04T002-NC9071	99616-C20	
2	99616-C3040-32	N9GX060204-NC2032	99616-C30 +	2支刀桿 + 10片刀片 + 1支扳手
	99616-C3040-71	N9GX060204-NC9071	99616-C40	
3	99616-C5052-32	N9GX090308-NC2032	99616-C50 +	2支刀桿 + 10片刀片 + 1支扳手
	99616-C5052-71	N9GX090308-NC9071	99616-C52	



4

密齒倒角刀

性能

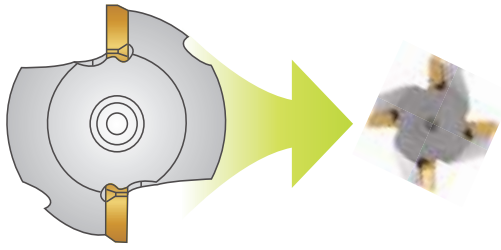

機台進給 $F =$
每刃進給 $f_z \times$ 轉速 $S \times$ 刃數 Z mm/min.

UP 刀具轉速 $S = \frac{\text{切削速度} \times 1000}{\pi \times C \text{min.}}$

► 測試結果 >> 範例1

• 倒角刀具搭配大型刀片 (Sxxx1204) 與 Nine9 N9GX04 刀片。

刀具		
切削資料	Nine 9 密齒倒角刀	大型刀片
倒角	1 mm	1 mm
進給速率 mm/rev.	0.1	0.1
刀具直徑 mm	11	32
切削刃	4	2
切削速度 V_c m/min.	300	200
主軸轉速 r.p.m.	8685	1990
進給速率 mm/min	3474	398

4

密齒倒角刀

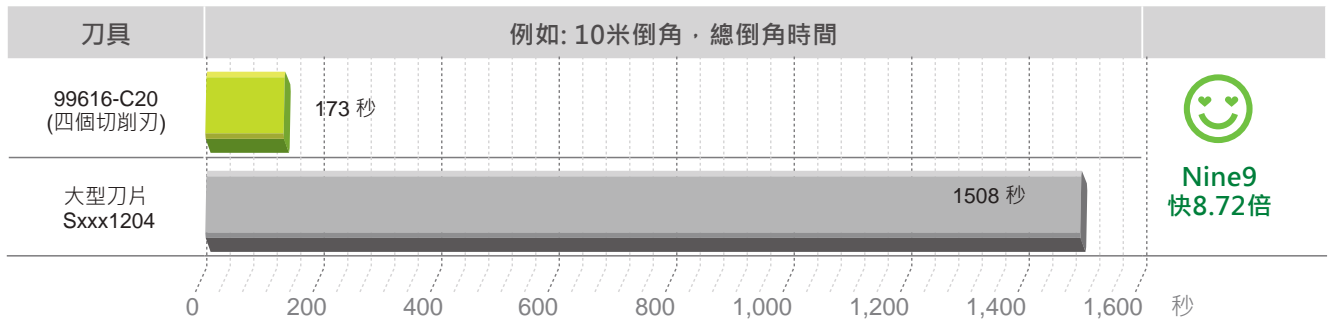
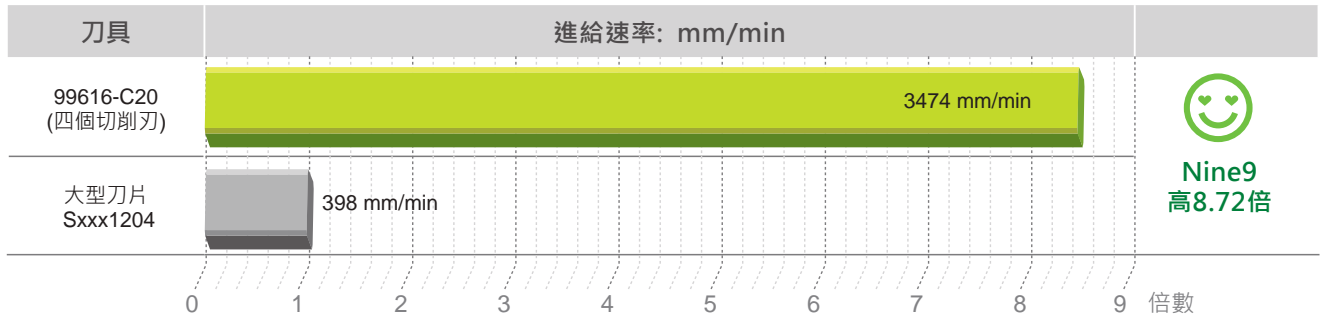

切削資料

▶ 99616-C02, C04, C06 切削資料 >>

工件材質		刀片材質	切削速率 VC m/min.	進給速率 mm / tooth	
材料組合	示範代碼 (JIS)			N9GX04T002	
				最大倒角值 1.5mm	
P	低碳鋼 C<0.3%	SS400	NC9071	60-80-120	0.02 ~ 0.07
	中碳鋼 C>0.3%	S50C, P5	NC2032	60-80-120	0.02 ~ 0.07
	低合金鋼 C<0.3%	SCM420	NC9071	60-80-120	0.01 ~ 0.04
	高合金鋼 C>0.3%	SKD11	NC2032	60-80-120	0.02 ~ 0.07
M	不鏽鋼	SUS304	NC9071	30-60-100	0.01 ~ 0.04
K	鑄鐵	FC25	NC2032	60-80-120	0.02 ~ 0.06
N	鋁・非鐵金屬材質	A6061	NC9071	80-100-150	0.03 ~ 0.10

▶ 99616-C10~C52 切削資料 >>

工件材質		刀片材質	切削速率 VC m/min.	進給速率 mm / tooth			
材料組合	示範代碼 (JIS)			N9GX04T002	N9GX060204	N9GX090308	
				最大倒角值 1.5mm	最大倒角值 2.5mm	最大倒角值 4mm	
P	低碳鋼 C<0.3%	SS400	NC9071	150-250-350	0.06~0.12	0.10~0.25	0.10~0.25
	中碳鋼 C>0.3%	S50C, P5	NC2032	200-300-400	0.06~0.10	0.10~0.20	0.10~0.25
	低合金鋼 C<0.3%	SCM420	NC9071	180-240-260	0.06~0.10	0.10~0.20	0.10~0.20
	高合金鋼 C>0.3%	SKD11	NC2032	120-150-200	0.06~0.10	0.10~0.15	0.10~0.15
M	不鏽鋼	SUS304	NC9071	120-150-180	0.06~0.10	0.06~0.15	0.10~0.20
K	鑄鐵	FC25	NC2032	120-150-180	0.06~0.10	0.10~0.15	0.10~0.20
N	鋁・非鐵金屬材質	A6061	NC9071	200-400-600	0.06~0.15	0.10~0.25	0.10~0.25
H	熱處理鋼 < HRC50°	SKD61	NC2032	80-90-100	0.06~0.10	0.06~0.12	0.10~0.15

4

密齒倒角刀



NC 電腦打洞刀 >>>

一支多功能的除料刀具

P M K N S H

▶ 兩種刀柄，鑽孔深度可達 8xDc

- 直柄 - 適用外部給水型
- 專利鎖牙型刀柄 - 適用內部給水型



Features >>>



▶ 鋸齒狀切削刃口

- 一種刀片能夠切削不同的材質。
- 特殊的刀片幾何形狀能夠切割不同的材料，並在鑽削難加工材料或鑽更深的孔時消除切屑和振動問題。出色的切屑控制，為現代自動化提供安全且順利的排屑。
- 每片刀片有2個切削刃口。

▶ 只要6支刀具，就可以生產 Ø13~Ø65mm 孔徑的工件

- 大幅降低刀具庫存，減低刀具成本。
- 加工時即使沒有內部出水，也無需啄鑽

▶ 20°高下降角，無論平面加工或圓形加工

- 螺旋加工，無論平面加工或圓形加工下降角最高可達20°

▶ 低馬力需求，容易切削。

不只可以達到鑽孔功能，也可以達到銑削功能



Applications

所有NC電腦打洞刀
· 均需採用螺旋運動加工

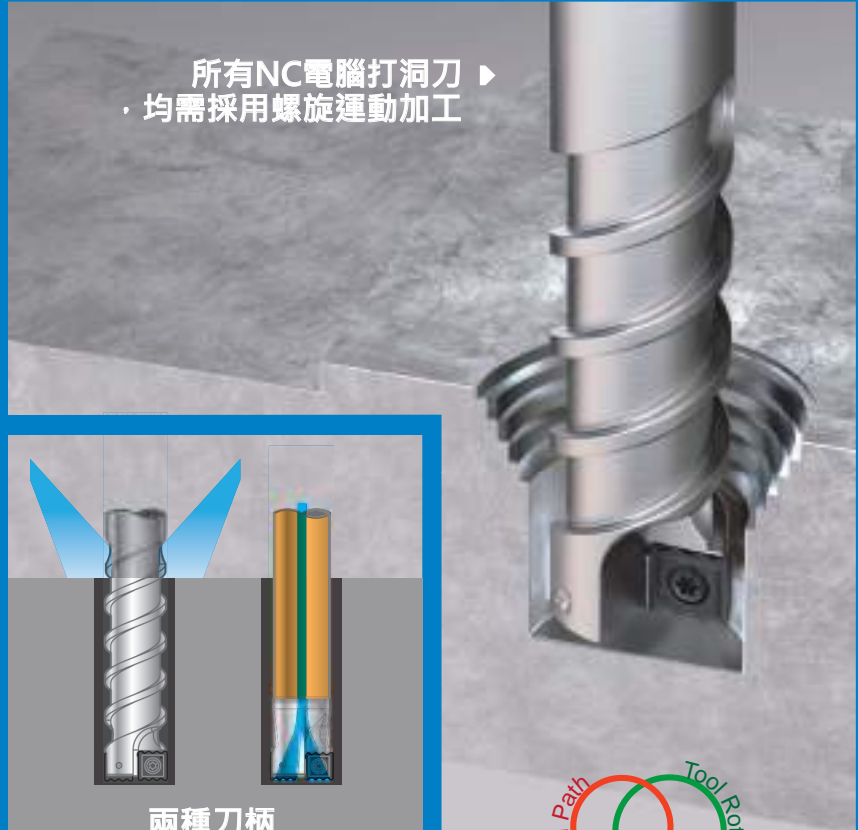

20°
最大
下降角度

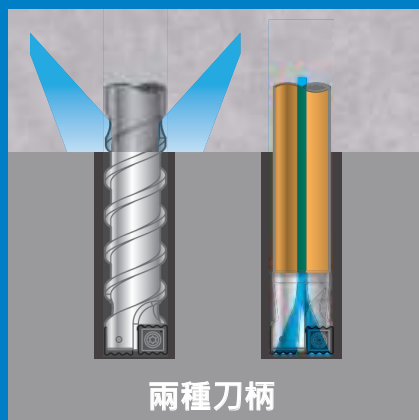

兩種刀柄

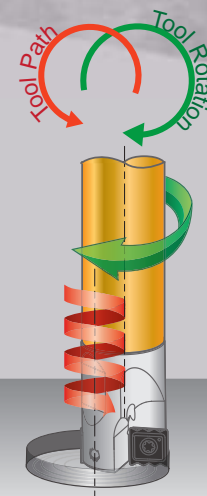

- “
- 一種工具多功能應用
 - 粗銑、打洞和開槽
 - 切屑容易排除 ”

5

NC電腦打洞刀



又小又短的切屑

NC 電腦打洞刀的特色

▶ 減少您的刀具庫存 >> 減低成本，性價比高

- 每支刀柄可以處理不同的直徑和孔深，節省您的刀具庫存和成本！
- 加工時即使沒有內部出水，也無需啄鑽。



▶ 低馬力需求 >> 容易切削

- 由於鋸齒狀切削刃的切削負載小，螺旋插補降低了功耗。加工更快、更容易，可取得更好的切削效果。
- 螺旋加工下降角最高可達20°
例如：HD27打洞刀，加工 $\phi 50\text{mm}$ 孔，材料是鋁合金，下降迴圈可達9mm；材料是碳鋼，下降迴圈可達6mm。

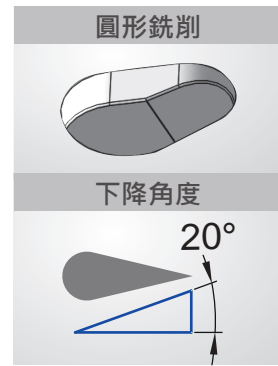

▶ 只要 6 支刀具，就可以生產 $\phi 13 \sim \phi 65 \text{ mm}$ 孔徑的工件 >>

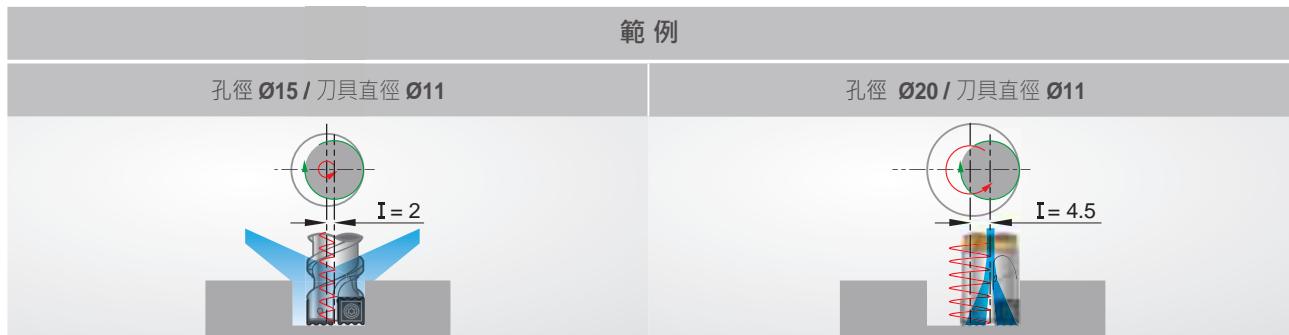

- 螺旋加工。
- 每支打洞刀，均能加工不同孔徑及深度。
- 採用 99323 中心出水刀桿可適用於擴孔。

▶ 特殊幾何形狀刀片，>> 讓切屑容易排除

- 特殊幾何形狀刀片，讓切屑容易排除絕不會產生纏屑現象，切屑外形變得又小又短，排屑容易又好控制
- 特殊的刀片幾何形狀能夠切割不同的材料，並在鑽削難加工材料或鑽更深的孔時消除切屑和振動問題。
- 出色的切屑控制，為現代自動化提供安全且順利的排屑。

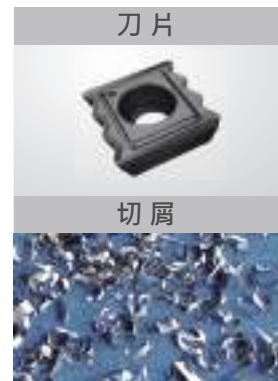

▶可在各種不同條件下，>>
進行切削加工

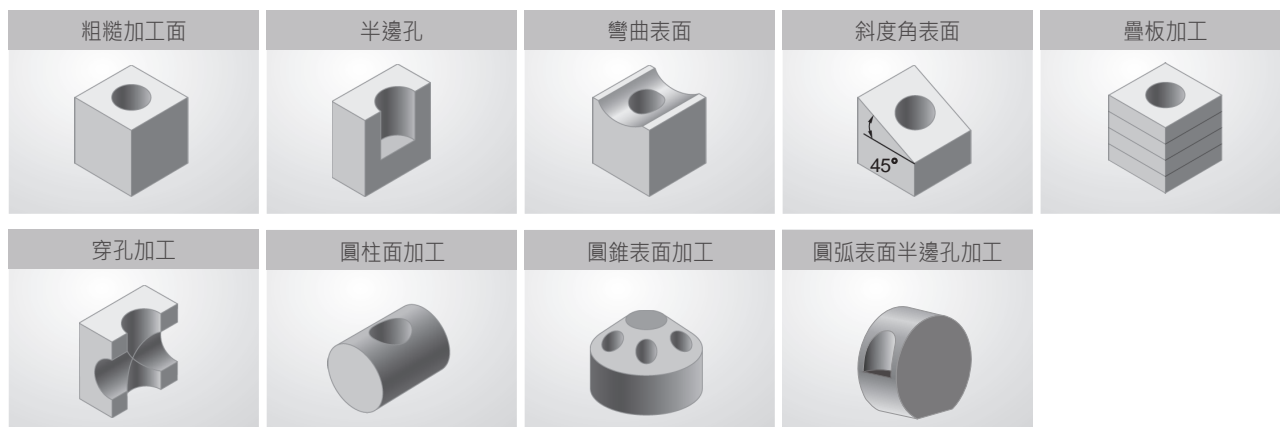

▶加工表面粗糙度 >>

- 加工底部平坦十分容易

Workpiece Application



到達深度後「再轉一圈」。

Ex :

...

G03 I-1.5 Z-30 P5

G03 I-1.5 <再轉一圈 >

G01 X0 Y0 <然後，讓刀具回到孔中心 >

Perthometer M1	
Object Name	
#	
Lt	5.800 mm
Ls Standard	2.5 μm
Lc	0.800 mm
Ra	1.476 μm
Rz	6.91 μm
Rmax	7.71 μm
RPc(0.5,-0.5)	48 /c
R Profile	
Lc	0.800 mm
VER	2.50 μm

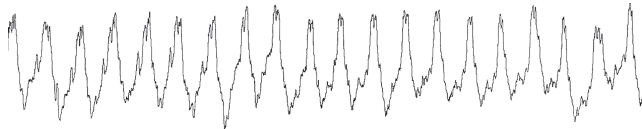

平坦

▶一支刀具多功能應用 >>

不同的刀具路徑就可在不同材料上切不同的大小孔、階梯孔、各種形狀的孔洞。

減少不同尺寸鑽頭和銑刀的庫存。

用 NC 打洞刀取代您的銑刀。

讓不可能變成可能！



NC 電腦打洞刀

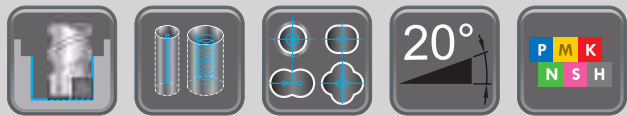

▶ 刀片 >>

NC5075 : P40底材, TiAlN+ALDURA雙鍍層。耐磨、耐高溫。適合熱處理鋼<HRC50°

NC5072 : P40底材, TiAlN鍍層。泛用材種, 適合鋼鐵, 不鏽鋼, 鈦合金

NC2032 : K20F底材, TiAlN鍍層, 可高速切削。

適合銅合金、長切屑軟金屬、鑄鐵, 硬化鋼<HRC50°

訂購編號	材質	鍍層	尺寸			螺絲	扳手
			L	S	Re		
N9MX04T002	NC5075	P40	4.75	1.8	0.2	NS-18037 0.6Nm	NK-T6
	NC5072	P40					
	NC2032	K20F					
N9MX05T103	NC5075	P40	5.75	2.0	0.3	NS-20045 0.6Nm	NK-T6
	NC5072	P40					
	NC2032	K20F					
N9MX070204	NC5075	P40	7.5	2.4	0.4	NS-25045 0.9Nm	NK-T7
	NC5072	P40					
	NC2032	K20F					
N9MX100306	NC5075	P40	10.0	3.18	0.6	NS-30072 2.0Nm	NK-T9
	NC5072	P40					
	NC2032	K20F					
N9MX12T308	NC5075	P40	12.5	3.97	0.8	NS-35080 2.5Nm	NK-T15
	NC5072	P40					
	NC2032	K20F					

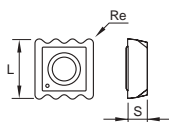

5

NC 電腦打洞刀

▶ 直柄刀桿 >>

- 專為沒有中心出水的CNC機器設計
- 獨特的螺旋除屑槽, 利用螺旋冷却水流, 將切屑排出
- 高硬度高合金鋼製作

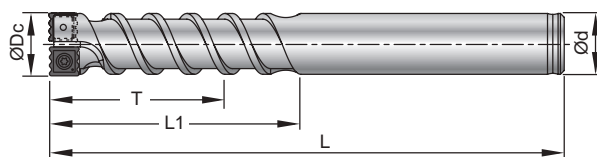

訂購編號	Part No.	可鑽孔直徑		ØDc	T	L1	L	Ød	最大深度	刀片類型	最大下降角
		Dmin.	Dmax.								
99321-010-1320	BC10-HD11-1320	13	20	11	30	40	80	10	30	N9MX04T002	20°
99321-012-1525	BC12-HD13-1525	15	25	13	36	50	100	12	36	N9MX05T103	20°
99321-016-2030	BC16-HD17-2030	20	30	17	50	60	110	16	50	N9MX070204	20°
99321-020-2540	BC20-HD22-2540	25	40	22	60	70	125	20	60	N9MX100306	20°
99321-025-3050	BC25-HD27-3050	30	50	27	75	85	165	25	75	N9MX12T308	20°

▶ 側固柄刀桿 >>

- 中心出水孔
- 特殊規格可訂製

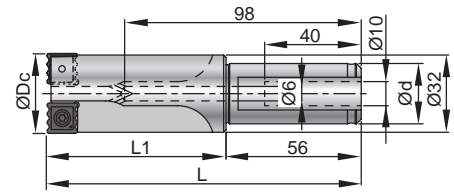

訂購編號	Part No.	可鑽孔直徑		ØDc	L	L1	Ød	最大深度	刀片類型	最大下降角
		Dmin.	Dmax.							
99321-025-4265	SL25-HD33-4265	42	65	33	130	74	25	50	N9MX12T308	9°

▶ 鎖牙型刀頭 >>

- 專為中心出水型的CNC機器設計
- 標準接桿可適用
- 可加工各種孔徑

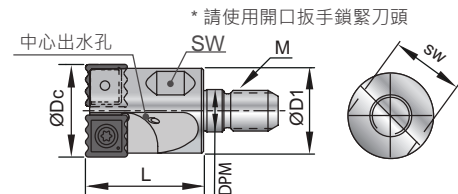

訂購編號	Part No.	可鑽孔直徑		ØDc	L	M	DPM	ØD1	SW	刀片類型	最大下降角
		Dmin.	Dmax.								
99323-010-1320	M05-HD11-1320	13	20	11	20	M5	5.5	10	8	N9MX04T002	20°
99323-012-1525	M06-HD13-1525	15	25	13	25	M6	6.5	12	10	N9MX05T103	20°
99323-016-2030	M08-HD17-2030	20	30	17	25	M8	8.5	16	14	N9MX070204	20°
99323-020-2540	M10-HD22-2540	25	40	22	30	M10	10.5	20	18	N9MX100306	20°
99323-025-3050	M12-HD27-3050	30	50	27	35	M12	12.5	25	23	N9MX12T308	20°

延長桿

▶ 鋼柄 >>

- T是最大可加工深度
- 中心出水型

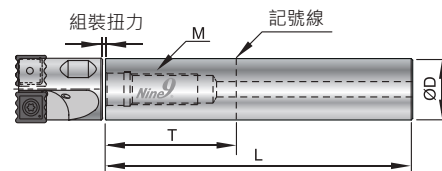

訂購編號	Part No.	ØD	T	L	M	組裝扭力
99801-10S	BC10-075M05S	10	25	75	M5xP0.8	6.5Nm
99801-12S	BC12-075M06S	12	25	75	M6xP1.0	11.0Nm
99801-14S	BC14-090M08S	14	30	90	M8xP1.25	25.0Nm
99801-16S	BC16-090M08S	16	35	90	M8xP1.25	25.0Nm
99801-18S	BC18-100M10S	18	40	100	M10xP1.5	50.0Nm
99801-20S	BC20-100M10S	20	40	100	M10xP1.5	50.0Nm
99801-25S	BC25-120M12S	25	50	120	M12xP1.75	60.0Nm

▶ 鎢鋼接桿 >>

- T是最大可加工深度
- 中心出水型
- 加長型接桿，需調整加工速度

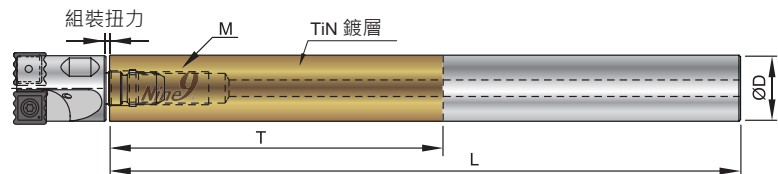

訂購編號	Part No.	ØD	T	L	M	組裝扭力
99801-10W	BC10-100M05W	10	50	100	M5xP0.8	6.5Nm
99801-12W	BC12-100M06W	12	60	100	M6xP1.0	11.0Nm
99801-14W	BC14-120M08W	14	70	120	M8xP1.25	25.0Nm
99801-16W	BC16-150M08W	16	80	150	M8xP1.25	25.0Nm
99801-18W	BC18-150M10W	18	90	150	M10xP1.5	50.0Nm
99801-20W	BC20-200M10W	20	100	200	M10xP1.5	50.0Nm
99801-25W	BC25-200M12W	25	125	200	M12xP1.75	60.0Nm

技術規範

► 使用之前請注意下列應用要點

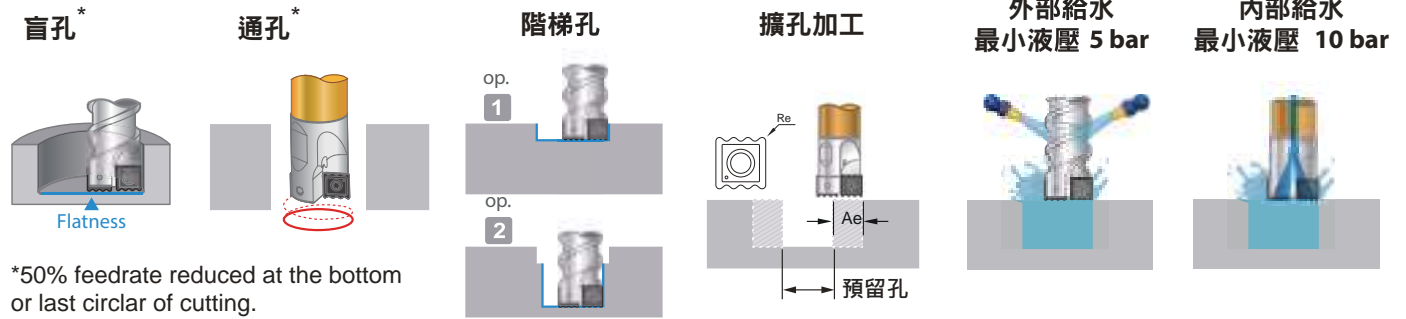

► 擴孔

用於擴孔加工時，Ae與Ap的最大與最小值。

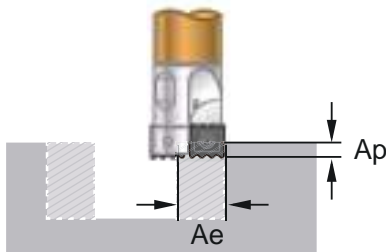

Ae 最大值 = Dc - (Re x 2)
Ae 最小值 = 1/3 的刀片長度 (L)
Ap 最大值 = 小於 3/4 的刀片長度

刀片	Re	最小Ae	最大 Ae	最大 Ap
N9MX04T002	0.2	1.6	10.6	3.5
N9MX05T103	0.3	2.0	12.4	4.3
N9MX070204	0.4	2.5	16.2	5.6
N9MX100306	0.6	3.3	20.8	7.5
N9MX12T308	0.8	4.2	25.4	9
N9MX12T308*	0.8	4.2	31.4*	9

(* 適用 99321-025-4265 刀桿)

NC 電腦打洞刀	切削公式 (S & F)	備註
	$S = \frac{Vc \times 1000}{Dc \times \pi} \text{ r.p.m.}$	Dc = 刀具直徑 mm
	$F = S \times fz \times Z \text{ mm/min.}$	D = 孔直徑 mm
	$d = D - Dc \text{ mm}$	L = 鑽孔深度 mm
	$I = \frac{(D - Dc)}{2} \text{ mm}$	Vc = 切削速度 m/min.
	加工時間 (T)	S = 刀具轉速 r.p.m.
	$T = \frac{\pi \times d \times L \times 60}{F \times P} \text{ sec.}$	I = 旋轉半徑 mm
	排屑容積率 (Q)	fz = 進給速率 mm/tooth
	$Q = \frac{\pi \times D^2 \times L \times 60}{4 \times 1000 \times T} \text{ cm}^3 / \text{min.}$	F = 進給速率 mm/min.
		d = 旋轉直徑 (D - Dc) mm
		P = 螺旋插補螺距 mm
	T = 加工時間 sec.	
	Q = 排屑容積率 cm ³ / min.	
	Z = 刃數	

► 主軸功率

The Feed rate (Fc) may be adjusted by the power factor (PF) of below:

$$Fc = FxPF \text{ (mm/min.)}$$

Spindle Type	BT-30			BT-40			BT-50		
	Small power			Medium power			Big power		
Spindle Power (KW)	< 5	7	10	12	16	20	22	25	> 30
Power Factor (PF)	0.8	0.85	0.9	0.95	1	1.05	1.1	1.15	1.2
Pitch (P)	Lower pitch			Medium pitch			Large pitch		

Remarks:

Fc: Adjusted Feed rate for real cutting
Pitch (P) can be selected according to spindle power.

► 99323 鎖牙型刀頭組裝

為確保牢固安裝，請使用扳手鎖緊刀頭，直到看不到間隙。

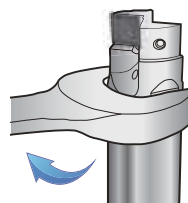

訂購編號	組裝扭力
99323-010-1320	6.5 Nm
99323-012-1525	11.0 Nm
99323-016-2030	25.0 Nm
99323-020-2540	50.0 Nm
99323-025-3050	60.0 Nm

▶ 僅適用螺旋插補或斜坡下降進給加工

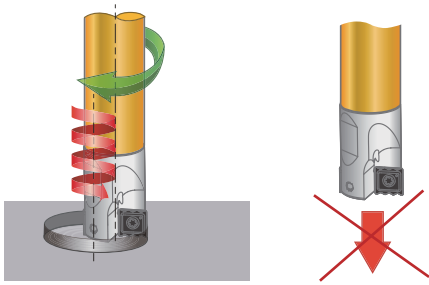

步驟 1: 在切削資料表 (第5-98 ~ 5-100頁) 上選擇切削速度 (Vc)、進給率 (f) 和螺距 (P)。進給速度和螺距請根據主軸功率進行調整，請參閱第5-96頁。

步驟 2: 決定旋轉半徑 I ($I = (D - D_c) / 2$)
對於擴大孔，決定Ae如第5-96頁。

步驟 3: 根據CNC控制器編寫螺旋插補程式。

此範例程式是針對 CNC 控制器的一般情況而編寫的。大多數CAD/CAM 系統都可以產生NC程式。

▶ 範例

1 盲孔程式

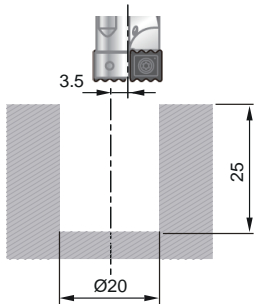

加工材質	N AL6061T6
刀桿	99321-012-1525
刀片	N9MX05T103-NC5072
Dc	ø13 mm
Vc	306 m/min.
f	0.065 mm/tooth
P	3 mm
I	$(20-13)/2 = 3.5$ mm

G00 G90 X3.5 Y0.
S7500 M03
G43 H01 Z30. M08
Z5.
G01 Z2. F500.
G03 I-3.5 Z-1. F975
G03 I-3.5 Z-4.
G03 I-3.5 Z-7.
G03 I-3.5 Z-10.
G03 I-3.5 Z-13.
G03 I-3.5 Z-16.
G03 I-3.5 Z-19.
G03 I-3.5 Z-22.
G03 I-3.5 Z-25.
G03 I-3.5 F500.
G01 X0. Y0.
G00 G90 Z5. M09
G00 G90 Z30. M05
G28 G91 Z0.

2 多階孔程式

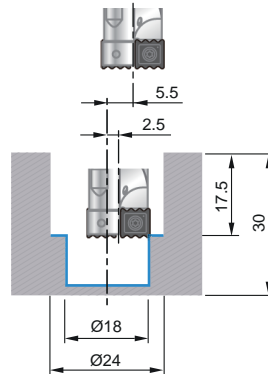

加工材質	P SCM440
刀桿	99323-012-1525
刀片	N9MX05T103-NC5072
Dc	ø13 mm
Vc	100 m/min.
For D1	ø24 mm
f1	0.07 mm/tooth
I1	$(24-13)/2 = 5.5$ mm
P1	2.4 mm
For D2	ø18 mm
f2	0.05 mm/tooth
I2	$(18-13)/2 = 2.5$ mm
P2	1.5 mm

G00 G90 X5.5 Y0. G03 I-2.5 Z-22.
S2450 M03 G03 I-2.5 Z-23.5
G43 H02 Z10. M08 G03 I-2.5 Z-25.
G01 Z1.7 F200. G03 I-2.5 Z-26.5
Z5. G03 I-2.5 Z-28.
G03 I-5.5 Z-0.7 F343. G03 I-2.5 Z29.5
G03 I-5.5 Z-3.1 G03 I-2.5 Z31.
G03 I-5.5 Z-5.5 G03 I-2.5 F150.
G03 I-5.5 Z-7.9 G01 X0. Y0.
G03 I-5.5 Z-10.3 G00 G90 Z5. M09
G03 I-5.5 Z-12.7 G00 G90 Z30. M05
G03 I-5.5 Z-15.1 G28 G91 Z0.
G03 I-5.5 Z-17.5
G03 I-5.5 F200.
G01 X2.5 Y0.
G03 I-2.5 Z-19. F245.
G03 I-2.5 Z-20.5

3 擴孔程式

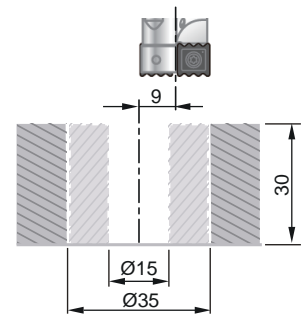

加工材質	K FCD400
刀桿	99321-016-2030
刀片	N9MX070204-NC5072
Prebore	15 mm
Dc	17 mm
Vc	90 m/min.
Pre-bored	ø15 mm
D	ø35 mm
f	0.1 mm/tooth
I	$(35-17)/2 = 9.0$ mm
P	4.0 mm

G00 G90 X9. Y0.
S1685 M03
G43 H03 Z30. M08
Z5.
G01 Z2. F200.
G03 I-9. Z-4. F337.
G03 I-9. Z-8.
G03 I-9. Z-12.
G03 I-9. Z-16.
G03 I-9. Z-20.
G03 I-9. Z-24.
G03 I-9. Z-28.
G03 I-9. Z-32.
G03 I-9. F200.
G01 X0. Y0.
G00 G90 Z5. M09
G00 G90 Z30. M05
G28 G91 Z0.

5

NC電腦打洞刀

切削資料

Pitch 選定建議初值			
主軸功率	< 12 KW	12-20 KW	> 20 KW
Pitch	低 Pitch	中 Pitch	高 Pitch

▶ 99321-010-1320 / 99323-010-1320 >>

工件材質	Vc m/min.		Ø13			Ø16				Ø20				
	99321	99323	fz mm/tooth	Pitch mm			fz mm/tooth	Pitch mm			fz mm/tooth	Pitch mm		
P 低碳鋼 0.25%C	120	200	0.025	0.60	0.80	1.00	0.055	0.90	1.20	1.50	0.08	1.20	1.60	2.00
	120	200	0.025	0.60	0.80	1.00	0.055	0.90	1.20	1.50	0.08	1.20	1.60	2.00
	100	150	0.025	0.60	0.75	0.90	0.05	0.80	1.10	1.35	0.07	1.00	1.40	1.80
	70	120	0.02	0.50	0.65	0.80	0.05	0.70	0.95	1.20	0.06	1.00	1.30	1.60
	60	90	0.02	0.50	0.65	0.80	0.05	0.70	0.95	1.20	0.06	1.00	1.30	1.60
M 不鏽鋼	60	90	0.02	0.50	0.65	0.80	0.05	0.70	0.95	1.20	0.06	1.00	1.30	1.60
K 鑄鐵	70	120	0.025	0.60	0.80	1.00	0.055	0.90	1.20	1.50	0.08	1.20	1.60	2.00
N 鋁	345	500	0.025	0.90	1.20	1.50	0.055	1.30	1.80	2.25	0.08	1.80	2.40	3.00
	200	400	0.025	0.70	0.95	1.20	0.055	1.00	1.40	1.80	0.08	1.40	1.90	2.40
S 鎳合金	20	28	0.01	0.50	0.65	0.80	0.015	0.70	0.95	1.20	0.03	0.90	1.30	1.60
	40	60	0.01	0.50	0.65	0.80	0.015	0.70	0.95	1.20	0.03	0.90	1.30	1.60
H 熱處理鋼	60	90	0.02	0.50	0.65	0.80	0.05	0.70	0.95	1.20	0.06	1.00	1.30	1.60

▶ 99321-012-1525 / 99323-012-1525 >>

工件材質	Vc m/min.		Ø15			Ø20				Ø25				
	99321	99323	fz mm/tooth	Pitch mm			fz mm/tooth	Pitch mm			fz mm/tooth	Pitch mm		
P 低碳鋼 0.25%C	120	200	0.035	1.20	1.60	2.00	0.065	1.50	2.00	2.50	0.09	1.80	2.40	3.00
	120	200	0.035	1.20	1.60	2.00	0.065	1.50	2.00	2.50	0.09	1.80	2.40	3.00
	100	150	0.03	1.10	1.50	1.80	0.06	1.30	1.78	2.25	0.08	1.60	2.15	2.70
	70	120	0.025	1.00	1.30	1.60	0.05	1.20	1.60	2.00	0.07	1.40	1.90	2.40
	60	90	0.025	1.00	1.30	1.60	0.05	1.20	1.60	2.00	0.07	1.40	1.90	2.40
M 不鏽鋼	60	90	0.025	1.00	1.30	1.60	0.05	1.20	1.60	2.00	0.07	1.40	1.90	2.40
K 鑄鐵	70	120	0.035	1.20	1.60	2.00	0.065	1.30	1.90	2.50	0.09	1.80	2.40	3.00
N 鋁	345	500	0.035	1.80	2.00	2.20	0.065	2.20	2.98	3.75	0.09	2.70	3.60	4.30
	200	400	0.035	1.40	1.90	2.20	0.065	1.80	2.40	3.00	0.09	2.10	2.85	3.60
S 鎳合金	20	28	0.0125	1.00	1.30	1.60	0.0225	1.20	1.60	2.00	0.03	1.40	1.90	2.40
	40	60	0.0125	1.00	1.30	1.60	0.0225	1.20	1.60	2.00	0.03	1.40	1.90	2.40
H 熱處理鋼	60	90	0.025	1.00	1.30	1.60	0.05	1.20	1.60	2.00	0.07	1.40	1.90	2.40



5

NC電腦打洞刀



切削資料

Pitch 選定建議初值			
主軸功率	< 12 KW	12-20 KW	> 20 KW
Pitch	低 Pitch	中 Pitch	高 Pitch

▶ 99321-016-2030 / 99323-016-2030 >>

工件材質	Vc m/min.		Ø20			Ø25				Ø30				
			fz mm/tooth	Pitch mm			fz mm/tooth	Pitch mm			fz mm/tooth	Pitch mm		
P 低碳鋼 0.25%C 0.45% C 0.60%C 低合金鋼 高合金鋼	120	200	0.04	1.80	2.40	3.00	0.08	2.10	2.80	3.50	0.105	2.40	3.20	4.00
	120	200	0.04	1.80	2.40	3.00	0.08	2.10	2.80	3.50	0.105	2.40	3.20	4.00
	100	150	0.035	1.60	2.15	2.70	0.07	1.90	2.55	3.20	0.09	2.10	2.85	3.60
	70	120	0.03	1.40	1.90	2.40	0.065	1.60	2.20	2.80	0.08	1.90	2.55	3.20
	60	90	0.03	1.40	1.90	2.40	0.065	1.60	2.20	2.80	0.08	1.90	2.55	3.20
M 不鏽鋼	60	90	0.03	1.40	1.90	2.40	0.065	1.60	2.20	2.80	0.08	1.90	2.55	3.20
K 鑄鐵	70	120	0.04	1.80	2.40	3.00	0.08	2.10	2.80	3.50	0.105	2.40	3.20	4.00
N 鋁 銅	345	500	0.04	2.70	3.00	3.40	0.08	3.10	4.05	5.00	0.105	3.60	4.80	5.60
	200	400	0.04	2.10	2.85	3.40	0.08	2.50	3.35	4.20	0.105	2.80	3.80	4.80
S 鎳合金 鈦合金	20	28	0.015	1.40	1.90	2.40	0.03	1.60	2.20	2.80	0.04	1.90	2.55	3.20
	40	60	0.015	1.40	1.90	2.40	0.03	1.60	2.20	2.80	0.04	1.90	2.55	3.20
H 熱處理鋼	60	90	0.03	1.40	1.90	2.40	0.065	1.60	2.20	2.80	0.08	1.90	2.55	3.20

▶ 99321-020-2540 / 99323-020-2540 >>

工件材質	Vc m/min.		Ø25			Ø32				Ø40				
			fz mm/tooth	Pitch mm			fz mm/tooth	Pitch mm			fz mm/tooth	Pitch mm		
P 低碳鋼 0.25%C 0.45% C 0.60%C 低合金鋼 高合金鋼	120	200	0.05	1.80	2.40	3.00	0.095	2.40	3.20	4.00	0.12	3.00	4.00	5.00
	120	200	0.05	1.80	2.40	3.00	0.095	2.40	3.20	4.00	0.12	3.00	4.00	5.00
	100	150	0.04	1.60	2.15	2.70	0.08	2.20	2.90	3.60	0.11	2.70	3.60	4.50
	70	120	0.035	1.40	1.90	2.40	0.07	1.90	2.55	3.20	0.095	2.40	3.20	4.00
	60	90	0.035	1.40	1.90	2.40	0.07	1.90	2.55	3.20	0.095	2.40	3.20	4.00
M 不鏽鋼	80	90	0.035	1.40	1.90	2.40	0.07	1.90	2.55	3.20	0.095	2.40	3.20	4.00
K 鑄鐵	70	120	0.05	1.80	2.40	3.00	0.095	2.40	3.20	4.00	0.12	3.00	4.00	5.00
N 鋁 銅	345	500	0.05	2.70	3.00	3.40	0.095	3.60	4.80	6.00	0.12	4.50	6.00	7.50
	200	400	0.05	2.10	2.85	3.40	0.095	2.90	3.85	4.80	0.12	3.60	4.80	6.00
S 鎳合金 鈦合金	40	50	0.02	1.40	1.90	2.40	0.035	1.90	2.55	3.20	0.045	2.40	3.20	4.00
	80	90	0.02	1.40	1.90	2.40	0.035	1.90	2.55	3.20	0.045	2.40	3.20	4.00
H 熱處理鋼	80	90	0.035	1.40	1.90	2.40	0.07	1.90	2.55	3.20	0.095	2.40	3.20	4.00



5

NC 電腦打洞刀

切削資料

Pitch 選定建議初值			
主軸功率	< 12 KW	12-20 KW	> 20 KW
Pitch	低 Pitch	中 Pitch	高 Pitch

▶ 99321-025-3050 / 99323-025-3050 >>

工件材質	Vc m/min.		Ø30			Ø40				Ø50				
	 99321	 99323	fz mm/tooth	Pitch mm			fz mm/tooth	Pitch mm			fz mm/tooth	Pitch mm		
P 低碳鋼 0.25%C 0.45% C 0.60%C 低合金鋼 高合金鋼	120	200	0.055	2.40	3.00	3.40	0.12	3.00	4.00	5.00	0.135	3.60	4.80	6.00
	120	200	0.055	2.40	3.00	3.40	0.12	3.00	4.00	5.00	0.135	3.60	4.80	6.00
	100	150	0.05	2.20	2.90	3.40	0.10	2.70	3.60	4.50	0.12	3.20	4.30	5.40
	70	120	0.04	1.90	2.55	3.20	0.09	2.40	3.20	4.00	0.11	2.90	3.85	4.80
	60	90	0.04	1.90	2.55	3.20	0.09	2.40	3.20	4.00	0.11	2.90	3.85	4.80
M 不鏽鋼	60	90	0.04	1.90	2.55	3.20	0.09	2.40	3.20	4.00	0.11	2.90	3.85	4.80
K 鑄鐵	70	120	0.055	2.40	3.00	3.40	0.115	3.00	4.00	5.00	0.135	3.60	4.80	6.00
N 鋁 銅	345	500	0.055	2.50	3.00	3.40	0.115	4.50	6.00	7.50	0.135	5.40	7.20	9.00
	200	400	0.055	2.50	3.00	3.40	0.115	3.60	4.80	6.00	0.135	4.30	5.75	7.20
S 鎳合金 鈦合金	20	28	0.02	1.90	2.55	3.20	0.045	2.40	3.20	4.00	0.055	2.90	3.85	4.80
	40	60	0.02	1.90	2.55	3.20	0.045	2.40	3.20	4.00	0.055	2.90	3.85	4.80
H 熱處理鋼	60	90	0.04	1.90	2.55	3.20	0.09	2.40	3.20	4.00	0.11	2.90	3.85	4.80

▶ 99321-025-4265 >>

工件材質	Vc m/min.	Ø42			Ø55				Ø65				
	 99321	fz mm/tooth	Pitch mm			fz mm/tooth	Pitch mm			fz mm/tooth	Pitch mm		
P 低碳鋼 0.25%C 0.45% C 0.60%C 低合金鋼 高合金鋼	200	0.08	3.00	3.60	4.40	0.12	3.30	4.40	5.50	0.135	3.60	4.80	6.00
	150	0.08	3.00	3.60	4.40	0.12	3.30	4.40	5.50	0.135	3.60	4.80	6.00
	130	0.075	2.70	3.60	4.40	0.11	3.00	4.00	5.00	0.12	3.20	4.30	5.40
	120	0.065	2.40	3.20	4.00	0.095	2.60	3.50	4.40	0.11	2.90	3.85	4.80
	90	0.065	2.40	3.20	4.00	0.095	2.60	3.50	4.40	0.11	2.90	3.85	4.80
M 不鏽鋼	90	0.065	2.40	3.20	4.00	0.095	2.60	3.50	4.40	0.11	2.90	3.85	4.80
K 鑄鐵	120	0.08	3.00	3.60	4.40	0.12	3.30	4.40	5.50	0.135	3.60	4.80	6.00
N 鋁 銅	500	0.08	4.00	4.20	4.40	0.12	4.90	6.55	8.20	0.135	5.40	7.20	9.00
	200	0.08	3.60	4.00	4.40	0.12	4.00	5.30	6.60	0.135	4.30	5.75	7.20
S 鎳合金 鈦合金	28	0.03	2.40	3.20	4.00	0.045	2.60	3.50	4.40	0.055	2.90	3.85	4.80
	90	0.03	2.40	3.20	4.00	0.045	2.60	3.50	4.40	0.055	2.90	3.85	4.80
H 熱處理鋼	90	0.065	2.40	3.20	4.00	0.095	2.60	3.50	4.40	0.11	2.90	3.85	4.80

5

NC電腦打洞刀

應用案例

► 特殊的加工方式可應用於多種材料上 >>

- 特殊的加工方式可應用於多種材料上。
- 幾乎所有材質都可加工，最適用於鑽孔時產生長軟屑的材料。



Material: SAE8620 Load 25% P Vc = 120 m/min. S = 2250 r.p.m. fz = 0.08 mm/tooth F = 360 mm/min P = 5.6 mm T = 40 sec.		Material: SUS304 (Stainless steel 304) Load 25% M Vc = 80 m/min. S = 1500 r.p.m. fz = 0.04 mm/tooth F = 120 mm/min P = 5.6 mm T = 118 sec.	
Material: C1100 Load 25% N Vc = 200 m/min. S = 3750 r.p.m. fz = 0.08 mm/tooth F = 600 mm/min P = 5.6 mm T = 23 sec.		Material: AL6061T6 Load 20% N Vc = 345 m/min. S = 6500 r.p.m. fz = 0.10 mm/tooth F = 1300 mm/min P = 5.6 mm T = 11 sec.	
Material: TiAl6V4 Load 24% S Vc = 80 m/min. S = 1500 r.p.m. fz = 0.04 mm/tooth F = 120 mm/min P = 5.6 mm T = 118 sec.		Material: Inconel 718 (Drill with internal coolant) Load 24% S Vc = 40 m/min. S = 750 r.p.m. fz = 0.15 mm/tooth F = 225 mm/min P = 2.0 mm T = 177 sec.	

► 刀片鍍層選擇 >>

Example 2	Diameter (mm)	25			
	Depth (mm)	50			
	Tool (Dc=17mm)	99321-016-2030 (external coolant)			
	Material		P Carbon Steel	M Stainless Steel	H Tool Steel
		DIN	C45E	X5CrNi18-10	X40CrMoV5 1
		SAE	1045	304	H13
		JIS	S45C	SUS304	SKD61 (HRC50°)
	Insert Grade	NC5072 (P40, TiAlN)	NC5072 (P40, TiAlN)	NC2032 (K20F, TiAlN)	
	No. of Edges	2	2	2	
	Vc = (m/min.)	120	40	80	
	S = r.p.m.	2250	750	1500	
	fz = (mm/tooth)	0.1	0.065	0.05	
	F = (mm/min.)	450	97.5	150	
	Pitch = (mm)	6	3	3	
Machine Load = % (BT40, 22.5KW)	35%	20%	20%		
Tool Life (hole)	150	108	18		
Chip Removal Volume (cm³)	52.66	8.55	8.77		

▶ 用同一把刀具加工53.5和45沉頭孔 >>

範例 1

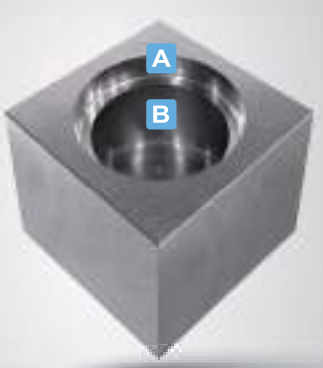

Application

- Hydraulic port for plug-in valve cylinders, counterbore for bolt, and more!



Material	S50C (JIS). High carbon steel									
Tool	99323-LS32-HD40 (Non-standard size)									
Insert	N9MX12T308-NC2032									
Machine	BT40, 22.5 Kw									
Coolant	Internal									
Hole	Dc mm	D mm	L mm	Vc m/min.	S r.p.m	fz mm/tooth	F mm/min.	I mm	P mm	T sec.
A	∅40	∅53.5	10	300	2400	0.08	380	6.75	5.0	13.3
B	∅40	∅45.0	32	300	2400	0.08	380	2.5	2.0	39.48

OP 1

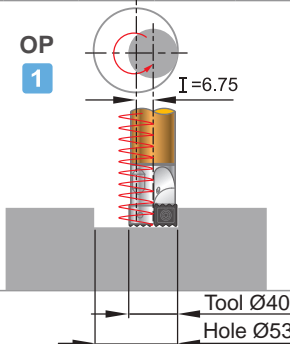

Tool ∅40
Hole ∅53.5

OP 2

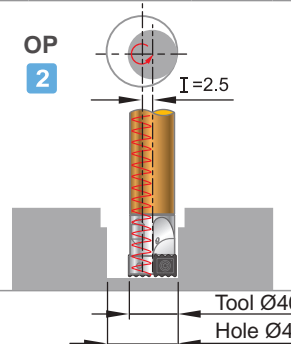

Tool ∅40
Hole ∅45

▶ Just one “NC Helix Drill” can machine different diameters and hole depths.

▶ 一支電腦打洞刀可加工不同孔徑與深度可能大於6xDc >>

範例 2

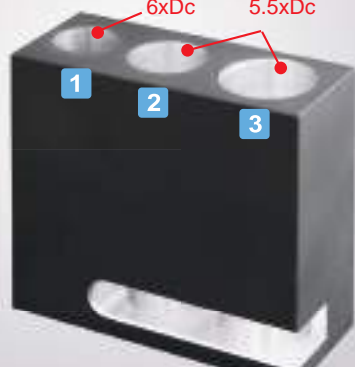

Material	AL6061T6										
Tool	99323-016-2030										
Insert	N9MX070204-NC5072										
Machine	HAAS VM-3, BT40, 22.5KW ($\eta=1$)										
Coolant	Internal coolant										
Fig.	Dc mm	D mm	I mm	L mm	Vc m/min.	S r.p.m	fz mm/tooth	fcut mm/tooth	F mm/min.	P mm	α deg
1		20	1.5	100	500	9360	0.04	0.058	1090	3	17.67
2	∅17	25	4	95	500	9360	0.08	0.103	1930	4.5	10.16
3		30	6.5	95	500	9360	0.105	0.131	2450	5.6	7.81

▶ 一支刀具可執行多種模式 >>

範例 3



Material	AL6061T6						
Tool	99323-016-2030 M08-HD17-2030						
Insert	N9MX070204-NC5072						
Machine	HAAS VM-3, BT40, 22.5KW						
Coolant	Internal						
Fig.	Dc mm	Vc m/min.	S r.p.m	fz mm/tooth	F mm/min.	P mm	T sec.
1		20	3800	0.075	570	4	67
2	∅17	25	3800	0.075	570	4	95
3		30	3800	0.075	570	4	80

▶ **NC 螺旋鑽擴孔不銹鋼深孔 (6xD) · 預鑽孔 15mm · 擴孔至 29mm · >>**

範例 4



Material		Stainless steel				
Tool		99323-016-2030 with 0-398016-150M08 Extension Bar				
Insert		N9MX070204-NC5072				
Machine		VMC m/c.				
Coolant		Internal coolant				
Dc mm	D mm	L mm	S r.p.m.	fz mm/tooth	F mm/min.	P mm
Ø17	Ø29	105	1685	0.05	168	1.5

▶ **低功率主軸上加工也沒有問題
BT30,加工孔徑30 · 3.3x Dc加工深度 在CNC機台上加工更具彈性 >>**
此範例主要在改善加工效率

範例 5

Maximum drilling capacity of the 5.5 kw spindle is Ø16 mm



Material		S50C (JIS), High carbon steel									
Tool		99321-020-2540 / BC20-HD22-2540									
Insert		N9MX100306-NC2032									
Machine		BT30, 5.5 KW									
Coolant		External coolant									
Dc mm	D mm	L mm	Vc m/min.	S r.p.m.	fz mm/tooth	fcut mm/tooth	F mm/min.	I mm	P mm	T sec.	
Ø22	Ø30	60	200	* 2893	0.12	0.1	600	4	2.8	62	

* 3000 r.p.m. is used.

5

NC 電腦打洞刀

▶ **NC 電腦打洞刀可降低主軸負載並延長主軸壽命 · >>**

範例 6

Maximum drilling capacity of the 18 kw spindle is Ø50 mm



Material		SS400 Low carbon steel									
Tool		99323-025-3050									
Insert		N9MX12T308-NC5072									
Machine		Toshiba MPE-2140, CAT-50, 25HP / 18KW									
Coolant		Internal coolant									
Dc mm	D mm	L mm	Vc m/min.	S r.p.m.	fz mm/tooth	fcut mm/tooth	F mm/min.	I mm	P mm	T sec.	
Ø27	Ø50	80	119	1400	0.15	0.165	420	11.5	3	275	

15% Spindle load only!



超倍比鑽頭 >>>

深孔鑽削深度可達 12 xD !

5xD & 10xD Ø19mm ~ Ø40mm

Nine9 “超倍比鑽頭” · 採用專利可轉位中心先導刀片設計，這是全球首次，有助於實現成本效益和良好的性能，使深孔鑽削達到12xD成為可能。



Features >>>



► 擁有鎢鋼中心鑽的捨棄式長鑽頭

- 更好的表面粗糙度。
- 更好的筆直度。
- 更好的圓度。



► 專利刀座設計

- 由於專利的型腔設計，側向切削力可以被中心刀片吸收。
- 獨特的刀片槽設計提供了最佳的中心刀片精度和剛性。
- 中心和周邊刀片的定位是為了將切屑分成更小的螺旋形狀。
- 它的設計目的在於實現最佳斷屑和良好的刃口處理，從而延長刀具壽命。





Applications



- “
- 專利的中心刀片有助於精準、穩定地進行深孔鑽削。
 - 更好的精加工表面，能減少搪孔時間。
- ”

Performance

熱交換器



半成品



連結履帶



6

超倍比鑽頭

刀片規範

中心鑽刀片



NC2032



NC40

▶ 特性 >>

- 特殊設計增加中心定位精準度，中心鑽與內切削刃結合為單一刀片，增加切削的穩定流動性
- 高精度研磨與表面處理，刀片壽命佳，加工表面優異
- 專利刀片座設計，讓中心鑽吸收切削阻力

NC2032 : K20F底材，AlTiN鍍層
泛用於C < 0.3%碳鋼，不鏽鋼

NC40 : P35底材，TiN鍍層
泛用於C > 0.3%碳鋼，不鏽鋼

訂購編號	鍍層	材質	尺寸	螺絲	扳手
99307-CD6	NC40	TiN		NS-35080 2.5Nm	NK-T15
	NC2032	AlTiN			
99307-CD8	NC40	TiN		NS-35120 2.5Nm	NK-T15
	NC2032	AlTiN			

外刃刀片

▶ 特性 >>

- 專利雙角度刀片
- 圓滑刃口處理，切屑穩定
- 刀片有4個切削刃口
- 刀片壽命佳



NC2032



NC40

NC2032: K20F底材，AlTiN鍍層，泛用於鋼鐵，鑄鐵，不鏽鋼，硬化鋼 < HRC50

NC40 : P35底材，適合低碳鋼，長屑型不鏽鋼，
只有二種規格 N9GX06020431 和 N9GX09030831

訂購編號	鍍層	材質	尺寸	螺絲	扳手
N9GX04T002	NC2032	AlTiN		NS-18037 0.6Nm	NK-T6
N9GX05T103	NC2032	AlTiN		K20F	NS-20045 0.6Nm
N9GX060204	NC2032	AlTiN		NS-22062 0.9Nm	NK-T7
N9GX06020431*	NC40	TiN			
N9GX090308	NC2032	AlTiN		NS-30072 2.0Nm	NK-T9
N9GX09030831*	NC40	TiN			

*31型刀片斷屑容易。

6

超倍比鑽頭

▶ NC定點鑽+ 超倍比鑽頭 >> 獲得完美的鑽孔

步驟 1	使用NC定點鑽定位		取得最佳定位點與尺寸公差 (請根據以下表格取得所需定位點尺寸)	
			超倍比鑽頭中心刀片	CD6 CD8
			定點鑽孔徑	Ø5 mm Ø7 mm
步驟 2	使用超倍比鑽頭鑽孔		定位點會引導超倍比中心鑽刀片並且穩定鑽頭加工，以實現完美的鑽孔操作。	
加工結果	切削速度	進給率	加工面	
無定位鑽	Vc= 80 m/min.	f = 0.1 mm/rev.		
使用定位鑽	Vc= 120 m/min.	f = 0.1 mm/rev.	 無震刀! 加工面平坦光亮 & 縮短加工時間	

50% Up
Efficient

▶ 表面粗度 >>

超倍比鑽頭刀片	工件材質: Carbon steel (S45C)			
99307-CD8 N9GX060204 NC40 NC2032	Vc	80	m/min.	
	S	880	r.p.m.	
	f	0.10	mm/z	
	F	88.0	mm/min.	
	Ra	2.139	µm	
	Rmax	11.8	µm	

```

Perthometer M1
Object
Name
#
L1 5.000 mm
Ls Standard 2.5 µm
Lc 0.000 mm
Ra 2.139 µm
Rz 10.6 µm
Rmax 11.8 µm
RPe(0.5,-0.5) 103 %
R Profile
Lc 0.000 mm
VER 0.00 µm
    
```

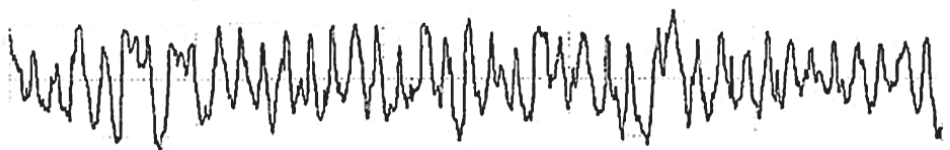

▶ 加工注意事項 >>

⚠ 1	⚠ 2	⚠ 3
中心定位	中心出水	鑽孔應用
偏心值 E 須小於 0.05mm.	中心需出水，建議水壓 10bar 以上較佳。	不適用於多層孔與斜面孔。

6

超倍比鑽頭

刀桿

19mm~40mm

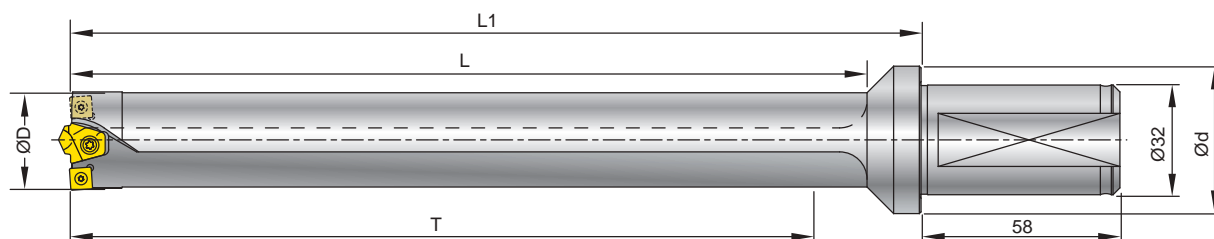







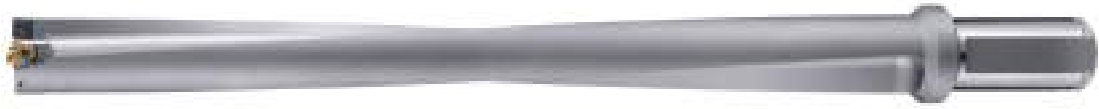

訂購編號	ØD mm (inch)	T	L	L1	Ød	刀片 / 螺絲 / 扳手	
						中心鑽刀片	外刃刀片
99307-19100	19 (0.748")	100	119	134	39		N9GX04T002 x 1 NS-18037 / 0.6Nm NK-T6
99307-19150		150	169	184			
99307-19200		200	219	239			
99307-20100	20 (0.787")	100	120	134	39		N9GX05T103 x 1 NS-20045 / 0.6Nm NK-T6
99307-20150		150	170	184			
99307-20200		200	220	239			
99307-21100	21 (0.827")	100	120	134	39		
99307-21150		150	170	184			
99307-21200		200	220	239			
99307-22100	22 (0.866")	100	125	139	39	99307-CD6 x 1	
99307-22150		150	175	189			
99307-22200		200	225	239			
99307-23100	23 (0.905")	100	125	139	39	NS-35080 2.5Nm	
99307-23150		150	175	189			
99307-23200		200	225	239			
99307-24100	24 (0.945")	100	126	139	39	NK-UT15	
99307-24150		150	176	189			
99307-24200		200	226	239			
99307-24250		250	276	289			N9GX060204 x 1 NS-22062 / 0.9Nm NK-T7
99307-25100	25 (0.984")	100	126	139	39		
99307-25150		150	176	189			
99307-25200		200	226	239			
99307-25250		250	276	289			
99307-26150	26 (1.024")	150	176	189	39		
99307-26200		200	226	239			
99307-26250		250	276	289			
99307-27150	27 (1.630")	150	181	198	43	99307-CD8 x 1	
99307-27200		200	231	248			
99307-27250		250	281	298			
99307-28150	28 (1.102")	150	181	198	43	NS-35120 2.5Nm	
99307-28200		200	231	248			
99307-28250		250	281	298			
99307-29150	29 (1.142")	150	182	198	43	NK-UT15	
99307-29200		200	232	248			
99307-29250		250	282	298			
99307-29300		300	332	348			N9GX060204 x 2 NS-22062 / 0.9Nm NK-T7

6

超倍比鑽頭



訂購編號	ØD mm (inch)	T	L	L1	Ød	刀片 / 螺絲 / 扳手	
						中心鑽刀片	外刃刀片
99307-30150	30 (1.181")	150	182	198	43		
99307-30200		200	232	248			
99307-30250		250	282	298			
99307-30300		300	332	348			
99307-31150	31 (1.220")	150	188	198	43		
99307-31200		200	238	248			
99307-31250		250	288	298			
99307-31300		300	338	348			
99307-32150	32 (1.260")	150	188	203	43		 N9GX060204 x 2
99307-32200		200	238	253			
99307-32250		250	288	303			
99307-32300		300	338	353			
99307-33150	33 (1.300")	150	189	203	43		 NS-22062 0.9Nm  NK-T7
99307-33200		200	239	253			
99307-33250		250	289	303			
99307-33300		300	339	353			
99307-34150	34 (1.339")	150	189	203	43	 99307-CD8 x 1	
99307-34200		200	239	253			
99307-34250		250	289	303			
99307-34300		300	339	353			
99307-34350		350	389	403			
99307-35200	35 (1.378")	200	245	258	43	 NS-35120 2.5Nm  NK-UT15	
99307-35250		250	295	308			
99307-35300		300	345	358			
99307-35350		350	395	408			
99307-36200	36 (1.417")	200	245	258	43		
99307-36250		250	295	308			
99307-36300		300	345	358			
99307-36350		350	395	408			
99307-37200	37 (1.457")	200	246	258	43		 N9GX090308 x 2
99307-37250		250	296	308			
99307-37300		300	346	358			
99307-37350		350	396	408			
99307-38200	38 (1.496")	200	246	258	43		 NS-30072 2.0Nm  NK-T9
99307-38250		250	296	308			
99307-38300		300	346	358			
99307-38350		350	396	408			
99307-39200	39 (1.535")	200	247	258	43		
99307-39250		250	297	308			
99307-39300		300	346	358			
99307-39350		350	397	408			
99307-40200	40 (1.575")	200	247	258	43		
99307-40250		250	297	308			
99307-40300		300	347	358			
99307-40350		350	397	408			

6

超
倍
比
鑽
頭

刀片規範

爆力鑽刀片- N9GL

訂購編號		尺寸			
		L	W	S	re
N9GL020204	NC40	7.12	4.90	2.20	0.4
N9GL020204LD	NC40	7.12	4.90	2.20	0.4
N9GL030204	NC40	8.71	6.00	2.50	0.4
N9GL030204LD	NC40	8.71	6.00	2.50	0.4
N9GL040304	NC40	10.76	7.38	2.85	0.4
N9GL040304LD	NC40	10.76	7.38	2.85	0.4

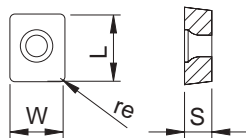

工件材質	加工狀況	刀片材種	線速 Vc (m/min.)	每轉進給 fz (mm/rev.)		
				N9GL020204	N9GL030204	N9GL040304
P 軟鐵	一般切削	(LD) NC40	150 (120~200)	0.05 (0.04~0.06)	0.08 (0.07~0.10)	0.10 (0.08~0.12)
	一般切削	NC40	130 (80~250)	0.07 (0.06~0.08)	0.09 (0.08~0.10)	0.12 (0.10~0.15)
P 碳鋼	不安定切削、斷續切削 中心刃易崩裂	(LD) NC40	100 (80~150)	0.07 (0.06~0.08)	0.08 (0.06~0.10)	0.10 (0.08~0.12)
	一般切削	NC40	120 (80~150)	0.06 (0.05~0.08)	0.08 (0.06~0.10)	0.10 (0.08~0.12)
P 合金鋼	不安定切削、斷續切削 中心刃易崩裂	(LD) NC40	80 (60~120)	0.04 (0.03~0.05)	0.06 (0.05~0.08)	0.08 (0.06~0.12)
	一般切削	(LD) NC40	80 (60~120)	0.05 (0.04~0.06)	0.06 (0.05~0.10)	0.07 (0.06~0.10)
M 不鏽鋼	一般切削	(LD) NC40	80 (60~120)	0.05 (0.04~0.06)	0.06 (0.05~0.10)	0.07 (0.06~0.10)
K 鑄鐵	一般切削	(LD) NC40	100 (80~150)	0.08 (0.04~0.10)	0.12 (0.10~0.15)	0.12 (0.10~0.20)
N 鋁合金	一般切削	(LD) NC40	200 (150~500)	0.06 (0.04~0.08)	0.06 (0.04~0.10)	0.08 (0.06~0.10)
S 鈦合金	一般切削	(LD) NC40	60 (40~70)	0.04 (0.03~0.05)	0.05 (0.04~0.06)	0.06 (0.05~0.08)

*鑽孔深度在1D (1倍直徑)以內可不用中心給水冷卻，但需外部給水。

爆力鑽刀片- N9GX

訂購編號		尺寸		
		L	S	re
N9GX05T308	NC40 NC30 NC10	5	3.8	0.8
N9GX05T30831	NC40	5	3.8	0.8
N9GX06T308	NC40 NC30 NC10	6	3.8	0.8
N9GX06T30831	NC40	6	3.8	0.8
N9GX070408	NC40 NC10	7	4.8	0.8
N9GX090508	NC10	9	5.3	0.8
N9GX090508HP	NC40	9	5.3	0.8

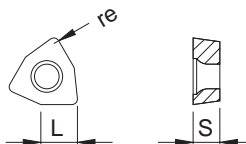

工件材質	加工狀況	刀片材種	線速 Vc (m/min.)	每轉進給 fz (mm/rev.)	
				N9GX05T3 / N9GX06T3	N9GX0704 / N9GX0905
P 軟鐵	一般切削、強迫斷屑	(31) NC40	100 (80~150)	0.10 (0.08~0.12)	-
	一般切削、長屑形	NC40	130 (120~150)	0.05 (0.04~0.07)	0.06 (0.05~0.07)
P 碳鋼	一般切削	NC40	100 (80~120)	0.10 (0.08~0.12)	0.13 (0.10~0.15)
	斷續切削、中心刃易崩裂	(31) NC40	90 (80~100)	0.08 (0.06~0.10)	-
	高正角(省力)	(HP) NC40	100 (80~120)	-	0.13 (0.10~0.15)
	耐磨(限外刃)	NC30	130 (120~150)	0.10 (0.08~0.12)	-
P 合金鋼	一般切削	NC40	100 (80~120)	0.10 (0.08~0.12)	0.10 (0.08~0.12)
	斷續切削、中心刃易崩裂	(31) NC40	80 (60~100)	0.08 (0.06~0.10)	-
	高正角(省力)	(HP) NC40	90 (80~100)	-	0.10 (0.08~0.12)
	耐磨(限外刃)	NC30	110 (100~120)	0.10 (0.08~0.12)	-
M 不鏽鋼	一般切削、強迫斷屑	(31) NC40	80 (60~120)	0.10 (0.08~0.12)	-
M 不鏽鋼	一般切削、長屑形	NC40	110 (100~120)	0.06 (0.05~0.07)	0.06 (0.05~0.07)
K 鑄鐵	一般切削	NC10	100 (80~120)	0.10 (0.08~0.15)	0.15 (0.10~0.20)
N 鋁合金	一般切削	NC10	300 (200~500)	0.09 (0.08~0.10)	0.10 (0.08~0.12)
S 鈦合金	一般切削	NC40	50 (30~60)	0.07 (0.05~0.08)	0.08 (0.06~0.10)

*鑽孔深度在1D (1倍直徑)以內可不用中心給水冷卻，但需外部給水。







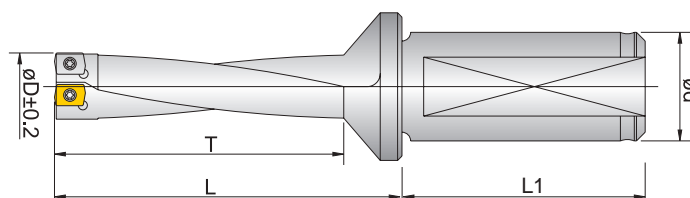

6

爆力鑽

爆力鑽刀桿(適用N9GL刀片)









3 x D 3 倍深



訂購編號	Part No.	ØD	T	L	L1	Ød	刀片	螺絲 / 扳手
99303-12.5L	NPD12.5L-37.5S25	12.5	37.5	58	55	25	 N9GL020204	 NS-20045 0.6Nm /  NK-T6
99303-13L	NPD13L-39S25	13	39	58	55			
99303-13.5L	NPD13.5L-40.5S25	13.5	40.5	60	55			
99303-14L	NPD14L-42S25	14	42	60	55			
99303-14.5L	NPD14.5L-43.5S25	14.5	43.5	62	55			
99303-15L	NPD15L-45S25	15	45	62	55			
99303-15.5L	NPD15.5L-46.5S25	15.5	46.5	64	55			
99303-16L	NPD16L-48S25	16	48	64	55			
99303-16.5L	NPD16.5L-48S32	16.5	48	69	59	32	 N9GL030204	 NS-22052 0.9Nm /  NK-T7
99303-17L	NPD17L-51S32	17	51	69	59			
99303-17.5L	NPD17.5L-51S32	17.5	51	72	59			
99303-18L	NPD18L-54S32	18	54	72	59			
99303-18.5L	NPD18.5L-54S32	18.5	54	76	59			
99303-19L	NPD19L-57S32	19	57	76	59			
99303-19.5L	NPD19.5L-57S32	19.5	57	81	59			
99303-20L	NPD20L-60S32	20	60	81	59			
99303-21L	NPD21L-63S32	21	63	84	59	32	 N9GL040304	 NS-25060 0.9Nm /  NK-T7
99303-22L	NPD22L-66S32	22	66	87	59			
99303-23L	NPD23L-69S32	23	69	91	59			
99303-24L	NPD24L-72S32	24	72	95	59			

爆力鑽刀桿 (適用N9GL刀片)

4 x D 4 倍深

訂購編號	Part No.	ØD	T	L	L1	Ød	刀片	螺絲 / 扳手
99304-13L	NPD13L-52S25	13	52	71	55	25	 N9GL020204	 NS-20045 0.6Nm /  NK-T6
99304-14L	NPD14L-56S25	14	56	74	55			
99304-15L	NPD15L-60S25	15	60	77	55			
99304-15.5L	NPD15.5L-62S25	15.5	62	80	55			
99304-16L	NPD16L-64S25	16	64	80	55			
99304-17L	NPD17L-68S32	17	68	85	59	32	 N9GL030204	 NS-22052 0.9Nm /  NK-T7
99304-18L	NPD18L-72S32	18	72	86	59			
99304-19L	NPD19L-76S32	19	76	90	59			
99304-19.5L	NPD19.5L-78S32	19.5	78	96	59			
99304-20L	NPD20L-80S32	20	80	96	59			
99304-21L	NPD21L-84S32	21	84	100	59	32	 N9GL040304	 NS-25060 0.9Nm /  NK-T7
99304-22L	NPD22L-88S32	22	88	104	59			
99304-23L	NPD23L-92S32	23	92	108	59			
99304-24L	NPD24L-96S32	24	96	112	59			









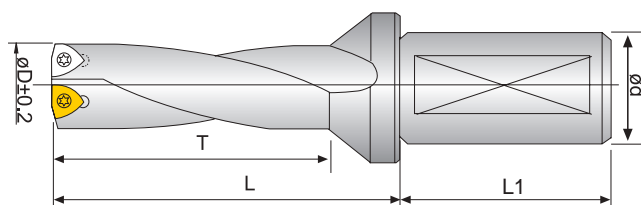



6

爆力鑽

爆力鑽刀桿(適用N9GX刀片)

3 x D 3 倍深



訂購編號	Part No.	ØD	T	L	L1	Ød	刀片	螺絲 / 扳手
99303-25	NPD25-75S32	25	75	99	60	32	 N9GX05T308	 NS-30072 / 2.0Nm  NK-T9
99303-26	NPD26-78S32	26	78	102	60			
99303-27	NPD27-81S32	27	81	105	60			
99303-28	NPD28-84S32	28	84	109	60			
99303-29	NPD29-87S32	29	87	112	60			
99303-30	NPD30-90S32	30	90	117	60			
99303-31	NPD31-93S32	31	93	121	60			
99303-32	NPD32-96S32	32	96	124	60			
99303-33	NPD33-99S32	33	99	128	60	32	 N9GX06T308	 NS-35080 / 2.5Nm  NK-T15
99303-34	NPD34-102S32	34	102	131	60			
99303-35	NPD35-105S32	35	105	135	60			
99303-36	NPD36-108S32	36	108	139	60			
99303-37	NPD37-111S32	37	111	142	60			
99303-38	NPD38-114S32	38	114	146	60			
99303-39	NPD39-117S32	39	117	146	60			
99303-40	NPD40-120S32	40	120	153	60			
99303-41	NPD41-123S40	41	123	158	70	40	 N9GX070408	 NS-35120 / 2.5Nm  NK-T15
99303-42	NPD42-126S40	42	126	161	70			
99303-43	NPD43-129S40	43	129	165	70			
99303-44	NPD44-132S40	44	132	168	70			
99303-45	NPD45-135S40	45	135	172	70			
99303-46	NPD46-138S40	46	138	175	70			
99303-47	NPD47-141S40	47	141	179	70			
99303-48	NPD48-144S40	48	144	182	70			
99303-49	NPD49-147S40	49	147	200	70	40	 N9GX090508	 NS-50125 / 5.5Nm  NK-T20
99303-50	NPD50-150S40	50	150	200	70			
99303-51	NPD51-153S40	51	153	200	70			
99303-52	NPD52-156S40	52	156	200	70			
99303-53	NPD53-159S40	53	159	200	70			
99303-54	NPD54-162S40	54	162	200	70			
99303-55	NPD55-165S40	55	165	200	70			
99303-56	NPD56-168S40	56	168	200	70			
99303-57	NPD57-171S40	57	171	200	70			
99303-58	NPD58-174S40	58	174	220	70			
99303-59	NPD59-177S40	59	177	220	70			
99303-60	NPD60-180S40	60	180	220	70			
99303-61	NPD61-183S40	61	183	220	70			
99303-62	NPD62-186S40	62	186	220	70			
99303-63	NPD63-189S40	63	189	220	70			
99303-64	NPD64-192S40	64	192	220	70			
99303-65	NPD65-195S40	65	195	220	70			
99303-66	NPD66-198S40	66	198	220	70			
99303-67	NPD67-201S40	67	201	220	70			
99303-68	NPD68-204S40	68	204	220	70			
99303-69	NPD69-207S40	69	207	220	70			









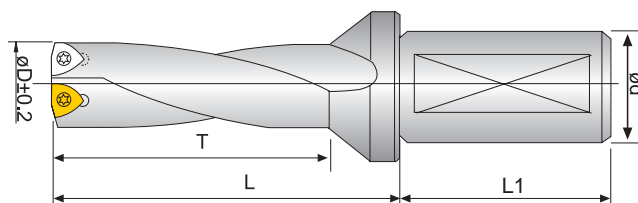



6

爆力鑽

爆力鑽刀桿(適用N9GX刀片)

4 x D 4 倍深



訂購編號	Part No.	ØD	T	L	L1	Ød	刀片	螺絲 / 扳手
99304-25	NPD25-100S32	25	100	119	60	32	 N9GX05T308	 NS-30072 2.0Nm /  NK-T9
99304-26	NPD26-104S32	26	104	123	60			
99304-27	NPD27-108S32	27	108	127	60			
99304-28	NPD28-112S32	28	112	131	60			
99304-29	NPD29-116S32	29	116	135	60			
99304-30	NPD30-120S32	30	120	157	60			
99304-31	NPD31-124S32	31	124	157	60			
99304-32	NPD32-128S32	32	128	157	60			
99304-33	NPD33-132S32	33	132	157	60	32	 N9GX06T308	 NS-35080 2.5Nm /  NK-T15
99304-34	NPD34-136S32	34	136	157	60			
99304-35	NPD35-140S32	35	140	182	60			
99304-36	NPD36-144S32	36	144	182	60			
99304-37	NPD37-148S32	37	148	182	60			
99304-38	NPD38-152S32	38	152	182	60			
99304-39	NPD39-156S32	39	156	182	60			
99304-40	NPD40-160S32	40	160	182	60			
99304-41	NPD41-164S40	41	164	200	70	40	 N9GX070408	 NS-35120 2.5Nm /  NK-T15
99304-42	NPD42-168S40	42	168	200	70			
99304-43	NPD43-172S40	43	172	200	70			
99304-44	NPD44-176S40	44	176	200	70			
99304-45	NPD45-180S40	45	180	215	70			
99304-46	NPD46-184S40	46	184	215	70			
99304-47	NPD47-188S40	47	188	215	70			
99304-48	NPD48-192S40	48	192	215	70			
99304-49	NPD49-196S40	49	196	215	70	40	 N9GX090508	 NS-50125 5.5Nm /  NK-T20
99304-50	NPD50-200S40	50	200	215	70			

6

爆力鑽

加工參數條件

5D~10D

工件材質分類計算

由於切削加工與機台操作樣式多元。以下根據ISO標準將材料簡略分類來劃分加工參數數值參考。有效參數指“特定切削力”，請參照下方表格與公式。(更詳細的材料分類表詳見公司網站)。

	Material Group	Material Type and description	Hardness HB	Strength N/mm ²	Specified cutting force kc N/mm ²
P	1.10	低碳鋼 C<0.3% 快削鋼	~125	500-850	1900
	1.20	中碳鋼 C>0.3%	~150	850-1000	2100
	1.30	低合金鋼 C<0.3%	180	Up to 750	2100
	1.40	低合金鋼 C>0.3%	200	750-1200	2600
	1.50	高合金鋼	200	800-1200	2600
	1.60	工具鋼 麻田散鐵不鏽鋼	<230	850-1100	2200
	1.70	鑄鋼			2900
M	2.10	快削不鏽鋼 沃斯田鐵不鏽鋼	200	490-700	2300
	2.20	難削不鏽鋼	175	650-850	2450
K	3.10	灰鑄鐵	180	250-350	1100
	3.20	可鍛鑄鐵	230	Up to 600	1200
	3.30	球墨鑄鐵	250	Up to 800	1800
N	4.10	鋁合金(矽<12%)	60	230-310	500
	4.20	鋁合金(矽>12%)	75	150-200	750
	4.30	非鐵金屬，鋳、鎂、銅合金	100	150-200	800
	4.40	碳、石墨、塑膠、木頭、橡膠	—	—	—
S	5.10	鎳基合金	250		3500
	5.20	鈷基合金	350		4150
	5.30	鐵基合金	250		3050
H	6.10	工具鋼、硬化鋼	HRC55		4500
	6.20	硬化鑄鐵	—	—	—

Formulas for Calculation of Machining Power Pc(Kw)

$$Pc(Kw) = \frac{f \times Vc \times D \times Kc}{60 \times 10^3 \times \eta}$$

feed force(KN) Ff

$$Ff = \frac{ap \times f \times Kc}{2000}$$

Drilling torque (Md)
torque=(Nm)

$$Md = \frac{f \times \pi \times D^2 \times Kc}{4000} \text{ Nm}$$

f = feed rate mm/rev.

Vc = cutting speed m/min.

D = drill diameter mm

Kc = specified cutting force N/mm²

η = power transmission efficiency of spindle (75%-85%)

切削資料

工件材質	T= Length/ Dia.	Vc (m/min.)	f (mm/rev.)				Grade of insert		
			N9GX04T002	N9GX05T103	N9GX060204	N9GX090308	Center	Periphery	
			Dia.19	Dia.20-21	Dia.22-34	Dia.35-40			
P 低碳鋼 C<0.3% Ex.:S25C, SS41	T<7D	80~150	0.03~0.07	0.04~0.08	0.06~0.10	0.08~0.12	NC2032	NC2032	
	T>7D	60~120	0.03~0.07	0.04~0.08	0.06~0.10	0.08~0.12			
	T<7D	80~130	—	—	0.06~0.10	0.08~0.12	NC40	NC40	
	T>7D	60~100	—	—	0.06~0.10	0.08~0.12			
	中碳鋼 C>0.3% Ex.:S50C, P5	T<7D	80~150	0.04~0.08	0.04~0.10	0.06~0.12	0.08~0.15	NC40	NC2032
		T>7D	60~120	0.04~0.08	0.04~0.10	0.06~0.12	0.08~0.15		
	低合金鋼 C<0.3% Ex.:SCM415	T<7D	60~150	0.04~0.08	0.04~0.10	0.06~0.10	0.08~0.12	NC2032	NC2032
		T>7D	40~120	0.04~0.08	0.04~0.10	0.06~0.10	0.08~0.12		
低合金鋼 C>0.3% Ex.:SCM440	T<7D	60~150	0.04~0.08	0.04~0.10	0.06~0.12	0.08~0.15	NC40	NC2032	
	T>7D	40~120	0.04~0.08	0.04~0.10	0.06~0.12	0.08~0.15			
高合金鋼 Ex.:SKD11	T<7D	60~120	0.03~0.07	0.04~0.08	0.06~0.10	0.08~0.12	NC40	NC2032	
	T>7D	40~100	0.03~0.07	0.04~0.08	0.06~0.10	0.08~0.12			
鑄鋼	T<7D	60~120	0.03~0.07	0.04~0.08	0.06~0.10	0.08~0.12	NC40	NC2032	
	T>7D	40~100	0.03~0.07	0.04~0.08	0.06~0.10	0.08~0.12			
M 不鏽鋼 Ex.:SUS304	T<7D	60~120	0.03~0.06	0.04~0.07	0.05~0.08	0.06~0.10	NC2032	NC2032	
	T>7D	40~100	0.03~0.06	0.04~0.07	0.05~0.08	0.06~0.10			
	T<7D	60~120	—	—	0.05~0.08	0.06~0.10	NC40	NC40	
	T>7D	40~100	—	—	0.05~0.08	0.06~0.10			
K 鑄鐵 Ex.:FC25	T<7D	60~120	0.04~0.08	0.04~0.10	0.06~0.10	0.08~0.12	NC40	NC2032	
	T>7D	40~100	0.04~0.08	0.04~0.10	0.06~0.10	0.08~0.12			
N 鋁·非金屬材質 Ex.:A6061	—	—	—	—	—	—	—	—	
	—	—	—	—	—	—	—	—	
H 熱處理鋼 <HRC50° Ex.:SKD61	T<7D	50~80	0.03~0.06	0.04~0.07	0.05~0.08	0.06~0.10	NC40	NC2032	
	T>7D	40~60	0.03~0.06	0.04~0.07	0.05~0.08	0.06~0.10			

重要資訊

- 前端開始3mm，降低進給50%，使用定心鑽，可以不用降減速度
- 加工速度以外刃計算
- 調整進給速率±25%，讓切屑更順暢
- 主軸切削力從新刀片開始計算到增加15%，必須更換新刀片
- 一定要使用中心出水，最低切削液壓力10 bar (大約150pai.)
- 臥式加工機鑽孔，可增加20%進給
- CNC車床鑽頭同心度要求偏擺±0.05mm以下，一定要鑽中心定位孔



真好鑽 >>>

3xD & 4xD

Ø10mm ~ Ø30mm

P **M** **K** **N**

▶ 尺寸範圍

3xD : Ø10 ~ Ø30mm

4xD : Ø16 ~ Ø30mm



Features >>>

▶ 最小切屑

- 內刃、外刃分割切屑，切屑細分後，切削快速，排屑容易
- 高速切削，一定使用切削液
- 中心出水

▶ 切削表面優異，尺寸安定

- 內外切削力平衡，加工表面優異，尺寸穩定

▶ 刀片有4個切削刃口，**AlTiN** 鍍層

- SD 刀片的斷屑槽因其工程設計而具有出色的切屑控制性能。
- 切削刃更換方便、迅速。





Applications

- ▶ 斜面加工
- 不用預加工平面，就可直接鑽孔

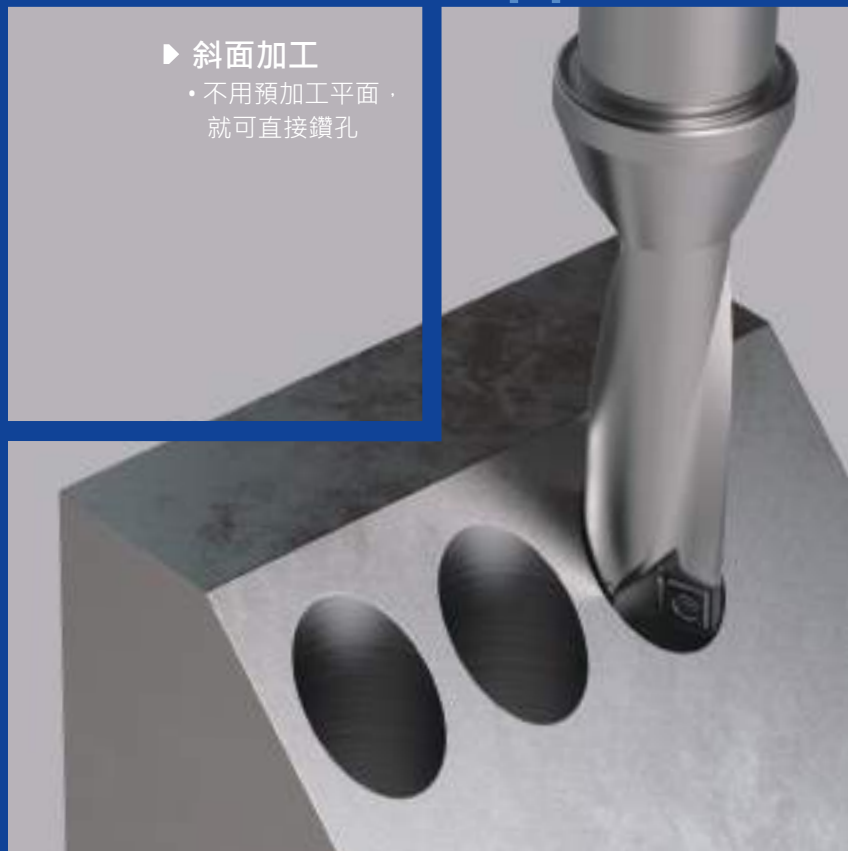

- “
- 最小尺寸 10mm。
 - 刀片有4個切削刃口。
 - 內刃外刃共用同一款刀片。”



6

真好鑽

刀片規範

刀片

特性

- 双角度刀片，加工表面優異，進給率高
- 双角度刀片，主離隙角更耐衝擊，第二離隙角可提高進給率
- 內刃、外刃同一款刀片
- 刀片有4個切削刃口，更經濟
- 加工表面優異
- 加工尺寸穩定



NC2032

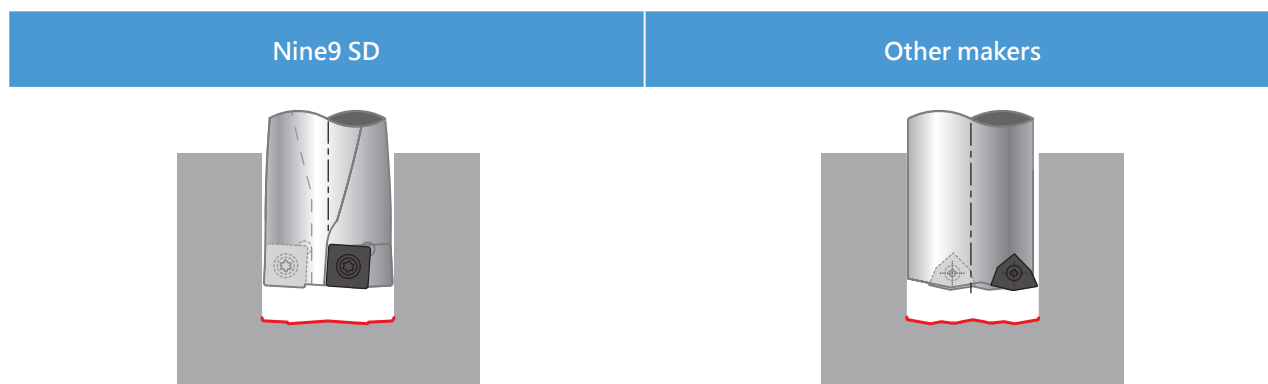

▶ 刀片 >>

NC2032: K20F底材，ALTiN鍍層，泛用於鋼鐵，鑄鐵，不鏽鋼，硬化鋼 < HRC50

訂購編號	鍍層	材質	尺寸	螺絲	扳手			
						L	S	re
N9GX04T002	NC2032	ALTiN	K20F	4.07	1.8	0.2	NS-18037 0.6Nm	NK-T6
N9GX05T103	NC2032	ALTiN	K20F	5.07	2.0	0.3	NS-20045 0.6Nm	NK-T6
N9GX060204	NC2032	ALTiN	K20F	6.35	2.38	0.4	NS-22055 0.9Nm	NK-T7
N9GX070304	NC2032	ALTiN	K20F	7.94	3.18	0.4	NS-25060 0.9Nm	NK-T7
N9GX090308	NC2032	ALTiN	K20F	9.52	3.18	0.8	NS-30072 2.0Nm	NK-T9

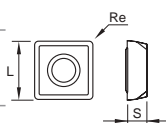

刀桿 3xD 10mm ~ 30mm

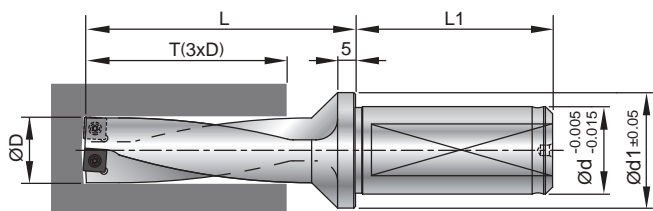

訂購編號	ØD	T	L	d	d1	L1	刀片 螺絲 / 扳手	Radial Adjustment	D max
99313-10	10.0	30.0	49	20	27	49		0.25	10.5
99313-10.3	10.3	30.9	52	20	27	49		0.25	10.8
99313-10.5	10.5	31.5	52	20	27	49	N9GX04T002	0.25	11.0
99313-11	11.0	33.0	52	20	27	49		0.20	11.4
99313-11.5	11.5	34.5	55	20	27	49	NS-18037 0.6Nm /	0.20	11.9
99313-12	12.0	36.0	55	20	27	49	NK-T6	0.15	12.3
99313-12.5	12.5	37.5	58	20	27	49		0.15	12.8
99313-13	13.0	39.0	58	20	27	49		0.30	13.6
99313-13.5	13.5	40.5	61	20	27	49	N9GX05T103	0.30	14.1
99313-14	14.0	42.0	61	20	27	49		0.25	14.5
99313-14.5	14.5	43.5	64	20	27	49	NS-20045 0.6Nm /	0.25	15.0
99313-15	15.0	45.0	64	20	27	49	NK-T6	0.20	15.4
99313-15.5	15.5	46.5	67	20	27	49		0.20	15.9
99313-16	16.0	48.0	74	25	31	55		0.40	16.8
99313-16.5	16.5	49.5	76	25	31	55		0.40	17.3
99313-17	17.0	51.0	76	25	31	55	N9GX060204	0.35	17.7
99313-17.5	17.5	52.5	78	25	31	55		0.35	18.2
99313-18	18.0	54.0	78	25	31	55	NS-22055 0.9Nm /	0.30	18.6
99313-18.5	18.5	55.5	80	25	31	55	NK-T7	0.30	19.1
99313-19	19.0	57.0	80	25	31	55		0.25	19.5
99313-19.5	19.5	58.5	85	25	31	55		0.25	20.0
99313-20	20.0	60.0	85	25	31	55		0.50	21.0
99313-20.5	20.5	61.5	87	25	31	55		0.50	21.5
99313-21	21.0	63.0	87	25	31	55	N9GX070304	0.45	21.9
99313-21.5	21.5	64.5	88	25	31	55		0.45	22.4
99313-22	22.0	66.0	88	25	31	55		0.40	22.8
99313-22.5	22.5	67.5	90	25	31	55	NS-25060 0.9Nm /	0.40	23.3
99313-23	23.0	69.0	90	25	31	55	NK-T7	0.35	23.7
99313-23.5	23.5	70.5	92	25	31	55		0.35	24.2
99313-24	24.0	72.0	92	25	31	55		0.30	24.6
99313-25	25.0	75.0	114	32	43	58		0.50	26.0
99313-26	26.0	78.0	115	32	43	58	N9GX090308	0.50	27.0
99313-27	27.0	81.0	117	32	43	58		0.40	27.8
99313-28	28.0	84.0	126	32	43	58	NS-30072 2.0Nm /	0.40	28.8
99313-29	29.0	87.0	127	32	43	58	NK-T9	0.30	29.6
99313-30	30.0	90.0	130	32	43	58		0.30	30.6

D max : 刀桿在車床上使用時，調整最大的容許直徑。

6

真好鑽

刀桿 4xD 16mm ~ 30mm

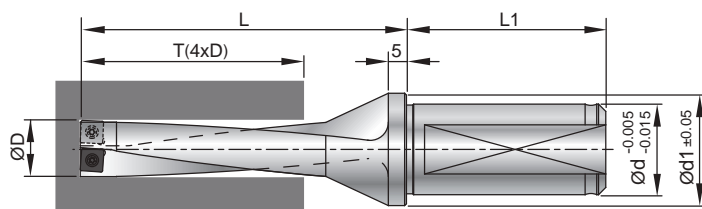

訂購編號	ØD	T	L	Ød	Ød1	L1	刀片 螺絲 / 扳手	Radial Adjustment	D max
99314-16	16	64	90	25	31	55	☑ N9GX060204 NS-22055 0.9Nm / NK-T7	0.40	16.8
99314-17	17	68	93	25	31	55		0.35	17.7
99314-18	18	72	96	25	31	55		0.30	18.6
99314-19	19	76	99	25	31	55		0.25	19.5
99314-20	20	80	105	25	31	55	☑ N9GX070304 NS-25060 0.9Nm / NK-T7	0.50	21.0
99314-21	21	84	108	25	31	55		0.45	21.9
99314-22	22	88	110	25	31	55		0.40	22.8
99314-23	23	92	113	25	31	55		0.35	23.7
99314-24	24	96	116	25	31	55		0.30	24.6
99314-25	25	100	139	32	43	58	☑ N9GX090308 NS-30072 2.0Nm / NK-T9	0.50	26.0
99314-26	26	104	141	32	43	58		0.50	27.0
99314-27	27	108	144	32	43	58		0.40	27.8
99314-28	28	112	154	32	43	58		0.40	28.8
99314-29	29	116	156	32	43	58		0.30	29.6
99314-30	30	120	160	32	43	58		0.30	30.6

加工應用

參數計算

應用狀態	*平坦表面	十字孔	堆疊鑽孔加工	圓形工件偏心鑽孔
工件形狀				
切削速度線速 Vc (m/min.)	100%	80%	80%~70%	80%~60%
進給率 (mm/rev.)	100%	80%	80%~70%	80%~60%
應用狀態	半邊孔	凹面加工	斜角面加工	圓錐體表面鑽孔
工件形狀				
切削速度線速 Vc (m/min.)	80%	80%	80%~70%	80%~70%
進給率 (mm/rev.)	80%	80%	80%~70%	80%~70%

* SPD 不適用

6

真好鑽

切削資料

工件材質	T= Length/ Dia.	Vc (m/min.)	f (mm/rev.)					Grade of insert
			N9GX 04T002	N9GX 05T103	N9GX 060204	N9GX 070304	N9GX 090308	
			Dia. 10~12.5	Dia. 13~15.5	Dia. 16~19.5	Dia. 20~24	Dia. 25~30	
P 低碳鋼 C<0.3% Ex.:S25C, SS41	T=3D	80~250	0.03~0.06	0.04~0.08	0.06~0.10	0.06~0.10	0.08~0.12	NC2032
	T=4D	60~180	—	—	0.06~0.10	0.06~0.10	0.08~0.12	
中碳鋼 C>0.3% Ex.:S50C, P5	T=3D	80~300	0.04~0.08	0.06~0.10	0.06~0.12	0.08~0.12	0.08~0.15	NC2032
	T=4D	60~150	—	—	0.06~0.12	0.08~0.12	0.08~0.15	
低合金鋼 C<0.3% Ex.:SCM415	T=3D	80~250	0.04~0.08	0.04~0.08	0.06~0.10	0.06~0.10	0.08~0.12	NC2032
	T=4D	60~150	—	—	0.06~0.10	0.06~0.10	0.08~0.12	
低合金鋼 C>0.3% Ex.:SCM440	T=3D	80~250	0.04~0.08	0.04~0.10	0.06~0.12	0.06~0.12	0.08~0.15	NC2032
	T=4D	60~150	—	—	0.06~0.12	0.06~0.12	0.08~0.15	
高合金鋼 Ex.:SKD11	T=3D	60~150	0.03~0.06	0.04~0.08	0.06~0.10	0.06~0.10	0.08~0.12	NC2032
	T=4D	50~100	—	—	0.06~0.10	0.06~0.10	0.08~0.12	
鑄鋼	T=3D	80~180	0.03~0.06	0.04~0.08	0.06~0.10	0.06~0.10	0.08~0.12	NC2032
	T=4D	60~120	—	—	0.06~0.10	0.06~0.10	0.08~0.12	
M 不鏽鋼 Ex.:SUS304	T=3D	60~150	0.03~0.06	0.04~0.08	0.04~0.10	0.06~0.10	0.06~0.12	NC2032
	T=4D	50~100	—	—	0.04~0.10	0.06~0.10	0.06~0.12	
K 鑄鐵 Ex.:FC25	T=3D	80~120	0.04~0.08	0.06~0.08	0.06~0.08	0.06~0.10	0.08~0.12	NC2032
	T=4D	60~100	—	—	0.06~0.08	0.06~0.10	0.08~0.12	
H 熱處理鋼 < HRC50° Ex.:SKD61	T=3D	60~100	0.03~0.06	0.04~0.08	0.05~0.08	0.06~0.08	0.06~0.10	NC2032
	T=4D	40~80	—	—	0.05~0.08	0.06~0.08	0.06~0.10	

* 在CNC車床上，鑽頭中心的最大偏心值為+0.2 mm / -0.5 mm

公制		英吋	
$S = \frac{Vc \times 1000}{\pi \times d}$	d = 直徑 -mm S = 刀具轉速 -r.p.m.	$S = \frac{(3.82 \times SFM)}{d}$	d = 直徑 -inch S = 刀具轉速 -r.p.m.
$F = S \times f$	Vc = 切削速度 -m/min. f = mm/rev. F = mm/min.	$SFM = Vc (m/min.) \times 3.28$	SFM = Surface Speed -ft./min. f = IPR = inch/rev. F = inch/min.



真好鑽



刀霸銑刀 >>>

Indexable Milling Cutter 10mm

捨棄式刀頭最小尺寸達10mm。
有直柄型、鎖牙型 2種選擇。
刀片擁有高進給、高耐磨特性



- ▶ 更高的進給率!
- ▶ 更高的耐磨性!
- ▶ 快速排屑!

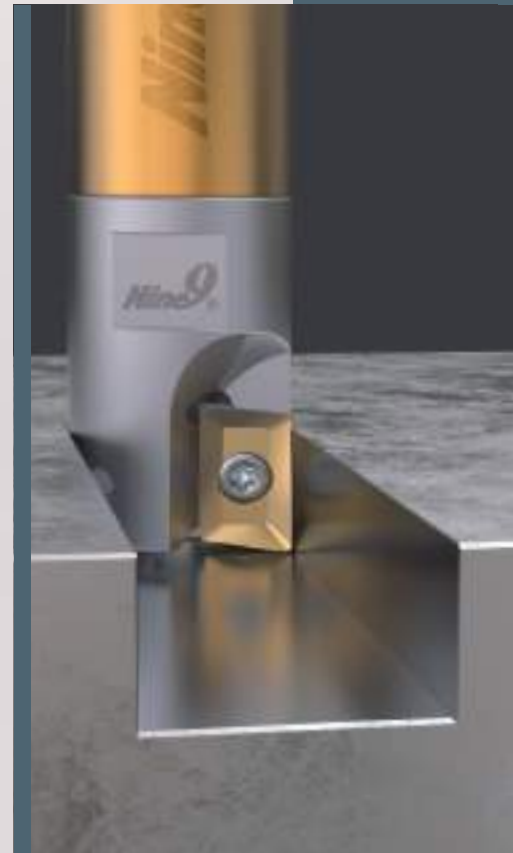

Features >

▶ A型銑刀片

- 超微粒刀片
- 高正角刀片
- 肩銑直角度佳

▶ R型刀片

- 超微粒刀片
- 特殊角度設計，適合3D模具精修
- R型刀片可作插銑加工

▶ C型清角刀片

- 超微粒刀片
- 特殊切削角設計，適合精修3D模具
- C型刀片可作插銑加工

▶ 十六面刀霸

- 適合M / C面銑加工
- 刀具成本低
- 超強刃口設計，進給可達0.5mm / tooth
- 刀片表面有序號，辨認快速

刀霸銑刀系統

A 型銑刀

Ø10-Ø25
 99802-BC..A..

Ø20 & Ø25
 99522..

Ø10-Ø25
 99802-M..A..
 99805-M..A..

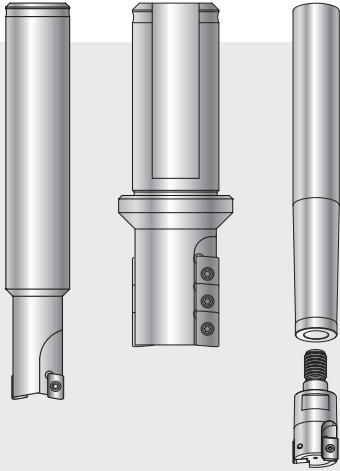

A9MT06...
 A9MT10...

C 型清角刀

Ø12-Ø25
 99802-BC..C..

Ø10-Ø26
 99802-M..C..
 99805-M..C..

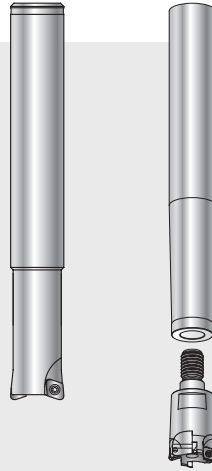

C9MT05...

R 型銑刀

Ø16-Ø35
 99802-BC..R..

Ø50-Ø100
 99802-MC..R..

Ø16-Ø35
 99802-M..R..

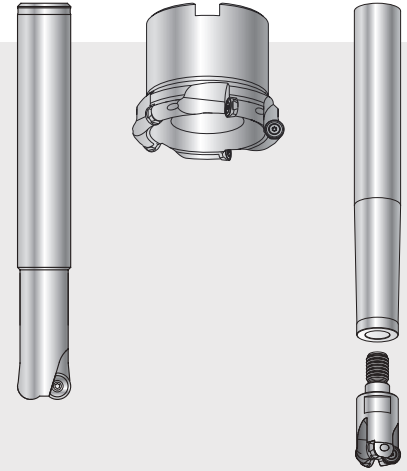

R9MT08...

十六面刀霸銑刀

Ø32
 99542-032 (粗銑)

Ø50-Ø125
 99542-... (CW)
 99542-... L (CCW)

Ø63, Ø80 and Ø100
 99543-063
 99543-080
 99543-100 (高速)

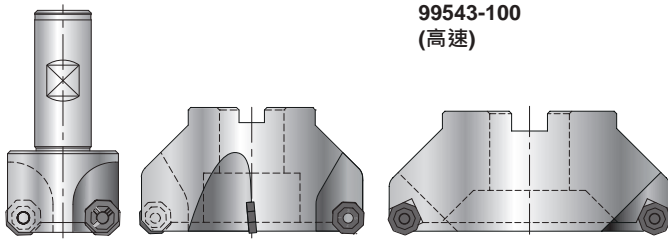

N9GJ11T3F2-0

特輕鋁合金銑刀

Ø80-Ø315mm
 99511-...

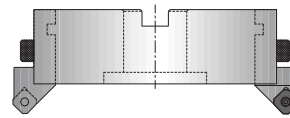

N9MT11T3HR300
 鏡面加工

N9GJ11T3F2
 鏡面加工

E 銑刀

Ø14-Ø25mm
 99617-...

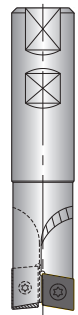

N9FX...
 高速鋼加工

7

刀霸系列

A型銑刀刀桿

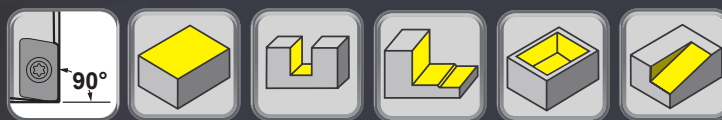

特色:

- 高強度設計，高正角切削
- 肩銑直角度佳

▶ 直柄型刀桿

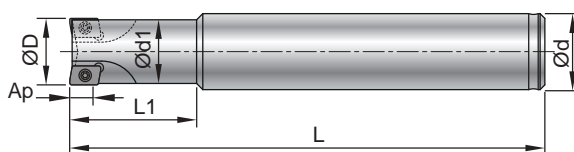
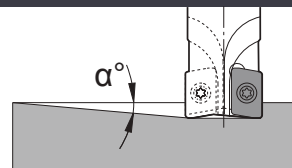

訂購編號	Part No.	ØD	No. of teeth	Ød h6	Ød1	α°	Ap	L1	L	刀片類型
99802-BC10-10A06	BC10-10A06-100	10	2	10	9.8	5.0	5	40	100	A9...0602...
99802-BC12-10A06	BC12-10A06-80	10	2	12	9.8	5.0	5	20	80	
99802-BC12-11A06	BC12-11A06-80	11	2	12	10.8	4.5	5	22	80	
99802-BC12-12A06	BC12-12A06-80	12	2	12	11.4	4.0	5	24	80	
99802-BC16-13A06	BC16-13A06-100	13	2	16	12.4	3.5	5	26	100	
99802-BC16-14A06	BC16-14A06-100	14	2	16	13.4	3.0	5	28	100	
99802-BC16-15A06	BC16-15A06-100	15	3	16	14.4	2.5	5	30	100	
99802-BC16-16A06	BC16-16A06-100	16	3	16	15.4	2.0	5	32	100	
99802-BC16-16A10	BC16-16A10-100	16	2	16	14.5	2.5	9	32	100	A9...1035...
99802-BC20-20A10	BC20-20A10-120	20	3	20	18.5	2.0	9	40	120	
99802-BC25-25A10	BC25-25A10-150	25	3	25	23.5	1.3	9	50	150	

▶ 密齒側銑刀

- 強力! 長刃銑刀 • BT40專用

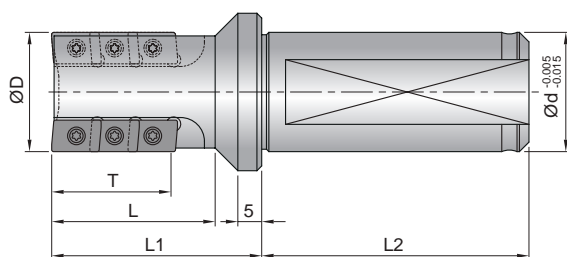

訂購編號	Part No.	ØD	No. of teeth	Ød	T	L	L1	L2	刀片類型
99522-20	SB20-EM20x3T	20	3	20	18	24.5	35	50	A9..1035...
99522-25	SB25-EM25x6T	25	6	25	25	34.25	44	56	

7

刀霸系列

A型銑刀刀桿

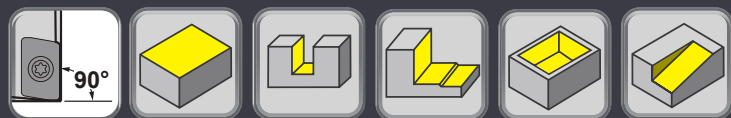

鎖牙型刀頭

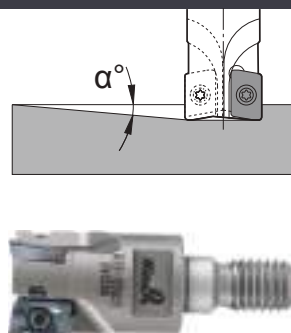
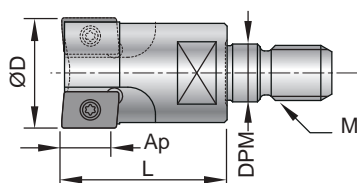

訂購編號	Part No.	ØD	No. of teeth	α°	Ap	L	M	DPM	刀片類型
99805-M05-10A06	M05-10A06	10	2	5.0	5	13	M5xP0.8	5.5	A9...0602...
99805-M05-11A06	M05-11A06	11	2	4.5	5	13	M5xP0.8	5.5	
99805-M06-12A06	M06-12A06	12	2	4.0	5	13	M6xP1.0	6.5	
99805-M06-13A06	M06-13A06	13	2	3.5	5	13	M6xP1.0	6.5	
99805-M08-14A06	M08-14A06	14	2	3.0	5	13	M8xP1.25	8.5	
99805-M08-15A06	M08-15A06	15	3	2.5	5	15	M8xP1.25	8.5	
99805-M08-16A06	M08-16A06	16	3	2.0	5	15	M8xP1.25	8.5	
99805-M08-17A06	M08-17A06	17	3	1.5	5	15	M8xP1.25	8.5	
99802-M08-16A10	M08-16A10	16	2	2.5	9	25	M8xP1.25	8.5	A9...1035...
99802-M10-20A10	M10-20A10	20	3	2.0	9	30	M10xP1.5	10.5	
99802-M12-25A10-3T	M12-25A10-3T	25	3	1.3	9	35	M12xP1.75	12.5	
99805-M12-25A10	M12-25A10	25	3	1.3	9	20	M12xP1.75	12.5	

* 延長桿請詳見7-133頁

7

刀霸系列

A型銑刀刀片



特色:

- 超微粒刀片，實現高精度切削。
- 良好的切削性能和高強度切削刃，可產生極佳的90°肩銑。

▶ 刀片

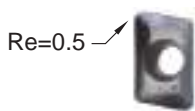

A9MT060205-NC5072

- 高強度設計，銑削安定
- 高正角切削，高移除率
- P40底材，適合鋼鐵

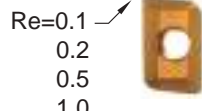

A9GT0602...H-NC9031

- 高正角切削，適合非鐵金屬加工
- K20F底材，適合鋁合金，銅合金，非鐵金屬

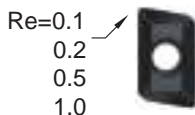

A9GT0602...H-NC2033

- 銳利的高正角切削，適合精修
- 表面加工優異
- K20F底材，適合鋼鐵

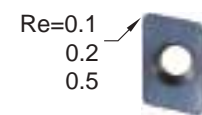

A9GT0602...U-NC2032

- U型刀片經過全磨削，減少切削時的切削阻力，是長柄刀具的最佳選擇。
- K20F底材，適合鋼鐵

刀片尺寸	訂購編號		鍍層	材質	Dimensions					螺絲 / 扳手	
					L	W	S	Re	Ap		
06	A9MT060205	NC5072	TiAlN	P40		6.5	4	2.45	0.5	5	NS-18037 0.6Nm / NK-T6
	A9GT060201H	NC2033	TiAlN	K20F		6.5	4	2.45	0.1	5	
		NC9031	TiN			6.5	4	2.45	0.2	5	
	A9GT060202H	NC2033	TiAlN	K20F		6.5	4	2.45	0.5	5	
		NC9031	TiN			6.5	4	2.45	0.5	5	
	A9GT060205H	NC2033	TiAlN	K20F		6.5	4	2.45	1.0	5	
		NC9031	TiN			6.5	4	2.45	0.1	5	
	A9GT060210H	NC2033	TiAlN	K20F		6.5	4	2.45	0.2	5	
A9GT060201U	NC2032	TiAlN	6.5		4	2.45	0.5	5			
A9GT060202U	NC2032	TiAlN	K20F	6.5	4	2.45	0.2	5			
A9GT060205U	NC2032	TiAlN		6.5	4	2.45	0.5	5			

7

刀霸系列

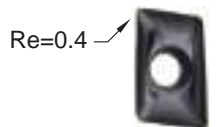

A9MT1035-NC2032

- 高強度設計，銑削安定
- 高正角切削，高移除率
- K20F底材，適合碳鋼、合金鋼

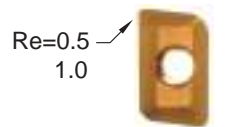

A9GT103510H-NC9031

- 高正角切削，適合非鐵金屬加工
- K20F底材，適合鋁合金，銅合金，非鐵金屬

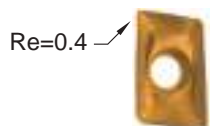

A9MT1035-NC40

- 高強度設計，銑削安定
- 高正角切削，高移除率
- P40底材，適合不鏽鋼

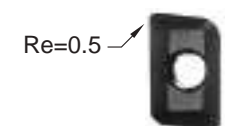

A9GT103505H-NC2032

- 銳利的高正角切削，適合精修
- 表面加工優異
- K20F底材，適合鋼鐵

刀片尺寸	訂購編號		鍍層	材質	Dimensions					螺絲 / 扳手	
					L	W	S	Re	Ap		
10	A9MT1035-NC2032		TiAlN	K20F		10	6.6	3.5	0.4	9	NS-25060 0.9Nm / NK-T7
	A9MT1035-NC40		TiN	P40		10	6.6	3.5	0.4	9	
	A9GT103505H-NC9031		TiN	K20F		10	6.6	3.5	0.5	9	
	A9GT103505H-NC2032		TiAlN	K20F		10	6.6	3.5	0.5	9	
	A9GT103510H-NC9031		TiN	K20F		10	6.6	3.5	1.0	9	

A型銑刀刀片

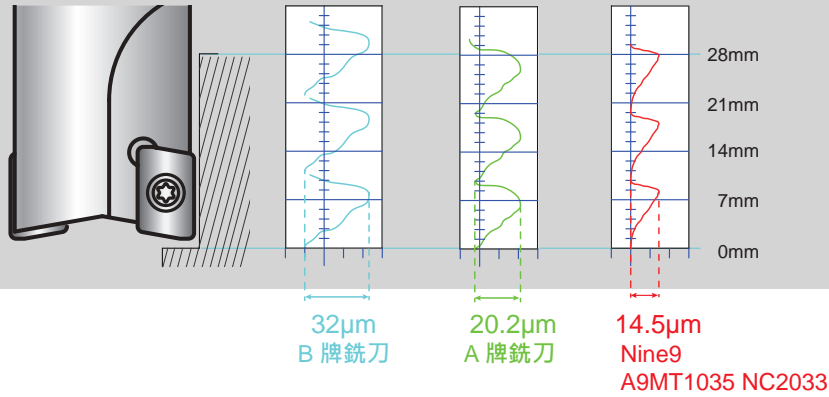

切削資料

- 開槽加工需降低 30% 進給速度
- 傾斜角度應小於 α°

▶ 刀片尺寸: 6.5mm (刀桿尺寸: Ø10~Ø17mm)

工件材質	代碼 (JIS)	刀片材種	Vc (m/min)	fz (mm/tooth)	Ap(mm)	Ae(mm)	Ae(mm)
P 碳鋼	P5	NC5072	80~150	0.03~0.07	1.5	4	1.5
		NC2033					
		NC5072					
P 低合金鋼 C ≤ 0.3%	SCM440	NC2033	80~150	0.03~0.07	1.5	4	1
		NC2032					
		NC5072					
P 高合金鋼 C > 0.3%	SKD11	NC2033	60~120	0.03~0.07	1	2.5	1
		NC2032					
		NC5072					
M 不鏽鋼	SUS304	NC5072	60~120	0.01~0.05	0.5	2	1
		NC2033					
K 鑄鐵	FC25	NC5072	60~120	0.03~0.07	1	2.5	1
		NC2033					
		NC5072					
K 可鍛鑄鐵·灰鑄鐵		NC2033	100~150	0.03~0.07	1.5	4	1.5
		NC5072					
N 鋁·鋁合金	A6061	NC9031	200~500	0.03~0.07	2	4	2

▶ 刀片尺寸: 10mm (刀桿尺寸: Ø16~Ø25mm)

工件材質	代碼 (JIS)	刀片材種	Vc (m/min)	fz (mm/tooth)	Ap(mm)	Ae(mm)	Ae(mm)
P 碳鋼	P5	NC2032	150~250	0.08~0.15	3	8	3
		NC2032					
		NC2032					
P 低合金鋼 C ≤ 0.3%	SCM440	NC2032	150~250	0.08~0.15	3	8	2
		NC2032					
		NC2032					
P 高合金鋼 C > 0.3%	SKD11	NC2032	120~200	0.08~0.15	2	4	2
		NC2032					
		NC2032					
M 不鏽鋼	SUS304	NC2032	80~120	0.04~0.08	1	4	2
		NC40					
K 鑄鐵	FC25	NC2032	120~200	0.08~0.12	2	5	2
		NC2032					
K 可鍛鑄鐵·灰鑄鐵		NC2032	100~150	0.06~0.10	3	8	3
		NC2032					
N 鋁·鋁合金	A6061	NC9031	200~500	0.03~0.07	5	8	3

7

刀霸系列

C型清角銑刀刀桿



特色:

- 適合角度精修。

▶ 直柄型刀桿

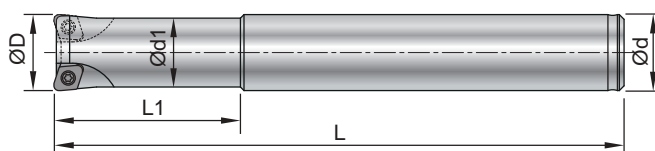
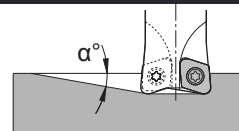

訂購編號	Part No.	ØD	No. of teeth	Ød h6	Ød1	α°	L1	L	刀片類型
99802-BC12-12C5	BC12-12C5	12	2	12	10.5	8.0	30	100	C9MT05T105 C9MT05T110H
99802-BC16-16C5	BC16-16C5	16	3	16	14.5	5.5	40	120	
99802-BC20-20C5	BC20-20C5	20	3	20	18	4.0	50	130	
99802-BC25-25C5	BC25-25C5	25	4	25	23	3.0	60	150	

▶ 鎖牙型刀頭

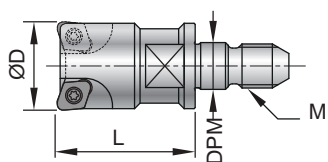

訂購編號	Part No.	ØD	No. of teeth	α°	L	M	DPM	刀片類型
99802-M06-12C5	M06-12C5	12	2	8	25	M6xP1.0	6.5	C9MT05T105 C9MT05T110H
99802-M06-13C5	M06-13C5	13	2	7.5	25	M6xP1.0	6.5	
99802-M08-16C5	M08-16C5	16	3	5.5	25	M8xP1.25	8.5	
99802-M08-17C5	M08-17C5	17	3	5	25	M8xP1.25	8.5	
99802-M10-20C5	M10-20C5	20	3	4	30	M10xP1.5	10.5	
99802-M10-21C5	M10-21C5	21	3	3.5	30	M10xP1.5	10.5	
99802-M12-25C5	M12-25C5	25	4	3	35	M12xP1.75	12.5	
99802-M12-26C5	M12-26C5	26	4	2.5	35	M12xP1.75	12.5	
99805-M05-11C5	M05-11C5	11	2	10	13	M5xP0.8	5.5	C9MT05T105 C9MT05T110H
99805-M06-12C5	M06-12C5	12	2	8	13	M6xP1.0	6.5	
99805-M06-13C5	M06-13C5	13	2	7.5	13	M6xP1.0	6.5	
99805-M08-16C5	M08-16C5	16	3	5.5	15	M8xP1.25	8.5	
99805-M08-17C5	M08-17C5	17	3	5	15	M8xP1.25	8.5	
99805-M10-20C5	M10-20C5	20	3	4	15	M10xP1.5	10.5	
99805-M10-21C5	M10-21C5	21	3	3.5	15	M10xP1.5	10.5	
99805-M12-25C5	M12-25C5	25	4	3	20	M12xP1.75	12.5	
99805-M12-26C5	M12-26C5	26	4	2.5	20	M12xP1.75	12.5	

* 延長桿請詳見7-133頁

7

刀霸系列

C型清角銑刀刀片



特色:

- 特殊角度設計，適合精修 3D 模具
- 超微粒刀片，實現高精度切削。
- C 型刀片可作插銑加工

▶ 刀片



C9MT05T110-NC30 C9MT05T105-NC30

- 正角刀片設計，泛用材質



C9MT05T110H-NC2032

- 高正角刀片設計
- 適合鋼鐵

Dual Relief Angle Insert

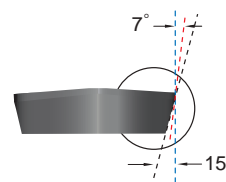

Higher feed rate!
Higher wearing resistance!

訂購編號	鍍層	材質	尺寸	尺寸			螺絲	扳手
				L	S	Re		
C9MT05T105-NC30	AlTiN	K10F		5	2.0	0.5	NS-20045 0.6Nm	NK-T6
C9MT05T110-NC30	AlTiN	K10F		5	2.0	1.0		
C9MT05T110H-NC2032	AlTiN	K20F		5	2.0	1.0		

切削資料

工件材質	代碼 (JIS)	刀片材種	Vc (m/min)	fz (mm/tooth)	Cutting Depth Ap(mm)
P 碳鋼	P5	NC30	150~300	0.2~0.5	0.2~0.5
		NC2032			
P 合金鋼	SCM440	NC30	120~250	0.2~0.5	0.2~0.5
		NC2032			
M 不鏽鋼	SUS304	NC30	120~200	0.2~0.4	0.2~0.4
		NC2032			
H 硬化鋼 < HRC52	SKD61	NC2032	100~150	0.1~0.3	0.1~0.3

* 建議 Ae 在 2.5mm 以下

7

刀霸系列

R型銑刀刀桿



特色：

- 高進給
- 特殊角度設計，適合3D模具精修
- R型刀片可作插銑加工

▶ 直柄型刀桿

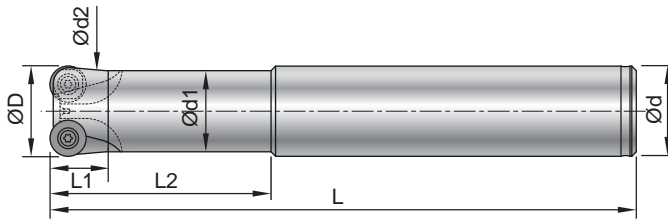
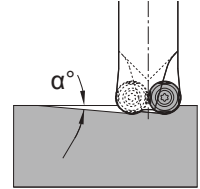

訂購編號	Part No.	ØD	No. of teeth	Ød	Ød1	Ød2	α°	L1	L2	L	刀片類型
99802-BC16-16R4	BC16-16R4-120	16	2	16	14.5	-	4.5	-	40	120	R9MT0803 R9MT0803F
99802-BC20-20R4	BC20-20R4-130	20	3	20	18	17	2.5	20	50	130	
99802-BC25-25R4-45°	BC25-25R4-150-45°	25	3	25	23	21	1.5	30	60	150	
99802-BC32-35R4	BC32-35R4-200	35	3	32	30	-	1.0	-	80	200	

25R4-45° 8 刃口刀桿，可供刀片再用 4 次刃口之特殊刀桿

▶ 圓刃銑刀頭

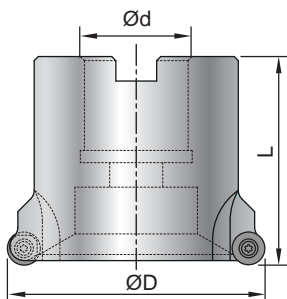

訂購編號	Part No.	ØD	No. of teeth	Ød	L	刀片類型
99802-MC22-50R4	MC22-50R4	50	4	22	51	R9MT0803 R9MT0803F
99802-MC25-63R4	MC25-63R4	63	5	25.4	51	
99802-MC25-80R4	MC25-80R4	80	5	25.4	51	
99802-MC31-100R4	MC31-100R4	100	6	31.75	61	

7

刀霸系列

R型銑刀刀桿



▶ 鎖牙型刀頭

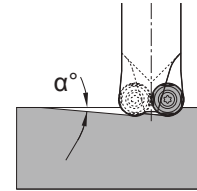
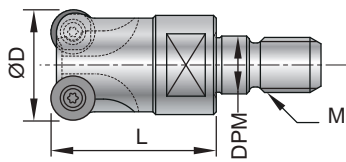

訂購編號	Part No.	ØD	No. of teeth	α°	L	M	DPM	刀片類型
99802-M08-16R4	M08-16R4	16	2	4.5	25	M8 x P1.25	8.5	R9MT0803 R9MT0803F
99802-M08-17R4	M08-17R4	17	2	4.0	25	M8 x P1.25	8.5	
99802-M10-20R4	M10-20R4	20	3	2.5	30	M10 x P1.5	10.5	R9MT0803 R9MT0803F
99802-M10-21R4	M10-21R4	21	3	2.0	30	M10 x P1.5	10.5	
99802-M12-25R4-3T (抗震或加長型使用)	M12-25R4-3T	25	3	1.5	35	M12 x P1.75	12.5	
99802-M12-26R4-3T (抗震或加長型使用)	M12-26R4-3T	26	3	1.3	35	M12 x P1.75	12.5	
99802-M16-35R4	M16-35R4-4T	35	4	1.0	40	M16 x P2.0	16.5	

* 延長桿請詳見7-133頁

7

刀霸系列

R型銑刀刀片

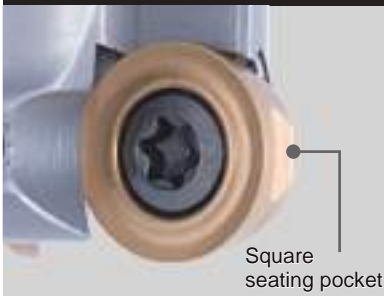

特色：

- 特殊刀片角度設計，用於精確定位，特別是在切削條件不穩定的情況下。

▶ 刀片



R9MT0803-NC40

- 高正角刀片設計
- 適合鋼鐵、鋁合金



R9MT0803F-NC2032

- 正角刀片設計，泛用材質

Dual Relief Angle Insert

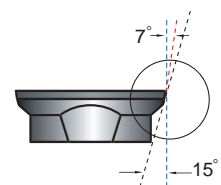

Higher feed rate!
Higher wearing resistance!

訂購編號	鍍層	材質	尺寸	螺絲	扳手
R9MT0803-NC40	TiN	K20F		NS-30072 2.0Nm	NK-T9
R9MT0803F-NC2032	AlTiN	K20F			

切削資料

工件材質	加工狀況	刀片材種	Vc (m/min)	fz (mm/tooth)	Cutting Depth Ap(mm)
P 中碳鋼	一般切削	NC2032	200 (150~250)	0.5 (0.3~0.8)	0.7 (0.4~1.0)
	斷續切削	NC2032	150 (120~180)	0.4 (0.3~0.5)	0.5 (0.4~0.6)
P 合金鋼	一般切削	NC2032	150 (120~180)	0.5 (0.3~0.6)	0.5 (0.4~0.6)
	斷續切削	NC2032	120 (100~150)	0.3 (0.2~0.4)	0.4 (0.3~0.6)
M 不鏽鋼 SUS	一般切削	NC40	120 (100~140)	0.4 (0.3~0.5)	0.4 (0.3~0.6)
H 硬化鋼 HRC52°	一般切削	NC2032	80 (60~120)	0.3 (0.2~0.4)	0.3 (0.3~0.4)
K 鑄鐵	一般切削	NC2032	150 (120~180)	0.5 (0.3~0.8)	0.5 (0.4~0.6)

刀具轉速 $S = Vc \times 1000 \div 3.14 \div \phi D$ (刀具直徑) 機台進給 $F = \text{轉速} S \times \text{每轉進給} fz \times \text{刃數} Z$

客戶粗胚切削深度習慣低 0.4mm · 建議使用 C9MT 系列刀頭 ·

切削阻力小 · 有效切削寬度增加 · 切削餘料更少。

延長桿

▶ 鋼柄

- T是最大可加工深度
- 中心出水型

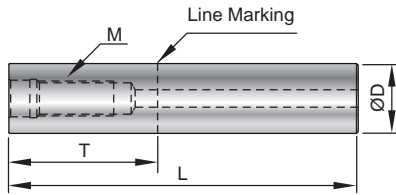

訂購編號	Part No.	ØD	T	L	M	Assemble Torque
99801-10S	BC10-075M05S	10	25	75	M5xP0.8	6.5Nm
99801-12S	BC12-075M06S	12	25	75	M6xP1.0	11.0 Nm
99801-14S	BC14-090M08S	14	30	90	M8xP1.25	25.0 Nm
99801-16S	BC16-090M08S	16	35	90	M8xP1.25	25.0 Nm
99801-18S	BC18-100M10S	18	40	100	M10xP1.5	50.0 Nm
99801-20S	BC20-100M10S	20	40	100	M10xP1.5	50.0 Nm
99801-25S	BC25-120M12S	25	50	120	M12xP1.75	60.0 Nm
99801-32S	BC32-150M16S	32	65	150	M16xP2.0	-

▶ 鎢鋼接桿

- T是最大可加工深度
- 中心出水型

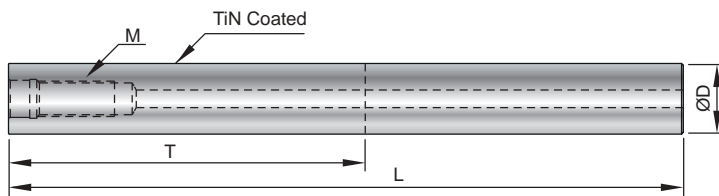

訂購編號	Part No.	ØD	T	L	M	Assemble Torque
99801-10W	BC10-100M05W	10	50	100	M5xP0.8	6.5 Nm
99801-12W	BC12-100M06W	12	60	100	M6xP1.0	11.0 Nm
99801-14W	BC14-120M08W	14	70	120	M8xP1.25	25.0 Nm
99801-16W	BC16-150M08W	16	80	150	M8xP1.25	25.0 Nm
99801-18W	BC18-150M10W	18	90	150	M10xP1.5	50.0 Nm
99801-20W	BC20-200M10W	20	100	200	M10xP1.5	50.0 Nm
99801-25W	BC25-200M12W	25	125	200	M12xP1.75	60.0 Nm

7

刀霸系列

十六面刀霸刀桿



特色:

- 適合 M / C 面銑加工
- 刀具成本低
- 超強結構，進給可達 0.5mm / tooth

▶ 刀桿

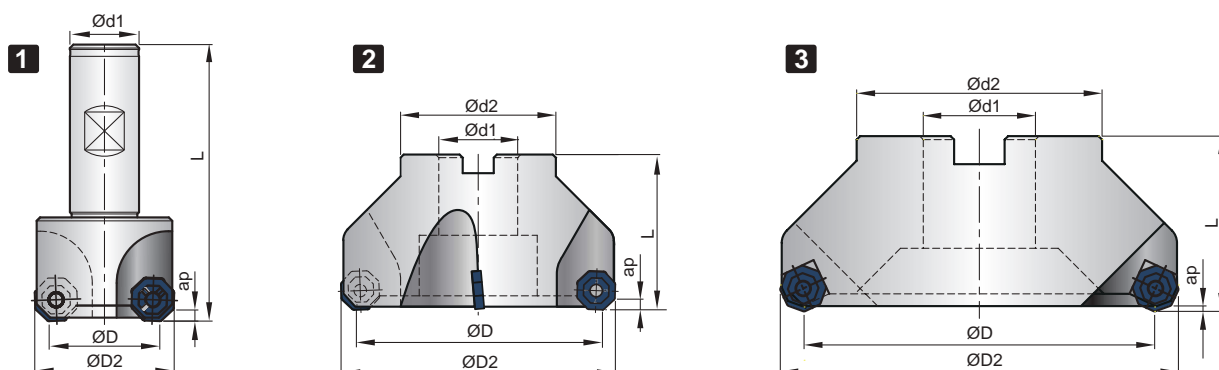

▶ 多刃粗銑刀 - Clockwise

圖示	訂購編號	Part No.	ØD	ØD2	No. of teeth	Ød1	Ød2	ap	L	刀片類型
1	99542-032	SB20-32R-11J	32	40	3	20	-	3	80	N9GJ11T3F2-0
	99542-050	MC22-50R-11J	50	58	3	22	50	3	45	
	99542-063	MC22-63R-11J	63	71	4	22	50	3	45	
2	99542-080	MC25.4-80R-11J	80	88	5	25.4	50	3	50	
	99542-100	MC31.75-100R-11J	100	108	6	31.75	70	3	50	
	99542-125	MC38.1-125R-11J	125	133	6	38.1	85	3	63	
3	99543-063	MC22-63R-11J-6T	63	75	6	22	50	1.5	45.5	
	99543-080	MC27-80R-11J-8T	80	92	8	27	60	1.5	50.5	
	99543-100	MC32-100R-11J-10T	100	113	10	32	70	1.5	50	

▶ 多刃粗銑刀 - Counterclockwise

圖示	訂購編號	Part No.	ØD	ØD2	No. of teeth	Ød1	Ød2	ap	L	刀片類型
	99542-050L	MC22-50L-11J	50	58	3	22	50	3	45	N9GJ11T3F2-0
	99542-063L	MC22-63L-11J	63	71	4	22	50	3	45	
2	99542-080L	MC25.4-80L-11J	80	88	5	25.4	50	3	50	
	99542-100L	MC31.75-100L-11J	100	108	6	31.75	70	3	50	
	99542-125L	MC38.1-125L-11J	125	133	6	38.1	85	3	63	

▶ 單刃精修刀

圖示	訂購編號	Part No.	ØD	ØD2	No. of teeth	Ød1	Ød2	ap	L	刀片類型
1	99544-032	SB20-32F-11J	32	40	1	20	-	0.2	80	N9GJ11T3F2-0
	99544-050	MC22-50F-11J	50	57	1	22	50	0.2	45	
2	99544-063	MC22-63F-11J	63	71	1	22	50	0.2	45	
	99544-080	MC25.4-80F-11J	80	87	1	25.4	50	0.2	50	

7

刀霸系列

十六面刀霸刀片

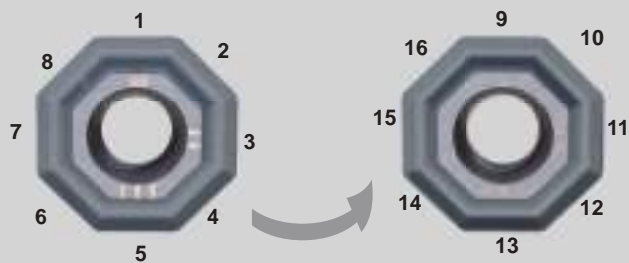

特色:

- 雙面刀片可降低成本
- 刀片表面有序號，辨認快速

▶ 刀片

Double-sided



N9GJ11T3F2-0

- 適合鋼鐵，不鏽鋼，鑄鐵
- 刀片有16個切削刃

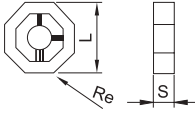
訂購編號	鍍層	材質		尺寸			螺絲	扳手
				L	S	Re		
N9GJ11T3F2-0-NC2032	AlTiN	K20F		12.2	3.97	0.8	NS-35080 2.5Nm	NK-T15

切削資料

工件材質	代碼 (JIS)	刀片材種	Vc (m/min.)	fz (mm / tooth)
P 中碳鋼	P5	NC2032	120~250	0.1~0.5
合金鋼	SCM440	NC2032	120~200	0.1~0.3
M 不鏽鋼	SUS304	NC2032	80~120	0.1~0.3
K 鑄鐵	FC25	NC2032	100~200	0.1~0.5

7

刀霸系列

特輕鋁合金製刀頭

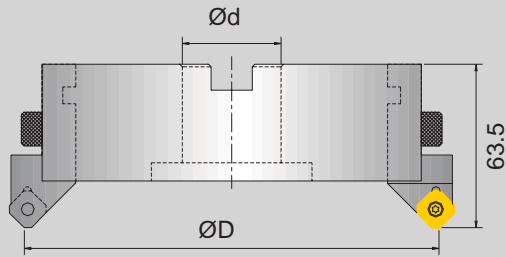

▶ 特色

- 一般鋼製本體刀頭 1/3~1/2 重量(160mm 鋼製約8.5kg)
- 適合 M/C · 大面積精銑 · 換刀重量受限時
- 特別適合鋁合金切削 · 尤其配合鑽石刀片之高速切削
- 特殊尺寸歡迎訂製
- 大面積單紋路面銑 · 一次加工無接縫
- 特殊刀尖調整裝置 · 調整容易 · 固定確實

訂購編號	Part No.	ØD	Ød	No. of teeth	*Kg	刀片 / 螺絲 / 扳手
99511-080	80S-AL	80	22	4	1.1	SEHW 1204 (45°) 螺絲：NS-45095 扳手：NK-T15
99511-100	100S-AL	100	22	4	1.4	
99511-125	125S-AL	125	38.1	4	2.1	
99511-160	160S-AL	160	38.1	4	2.9	
99511-200	200S-AL	200	38.1	4	4.2	
99511-250	250S-AL	250	38.1	4	6.5	
99511-315	315S-AL	315	38.1	6	8.0	

*Kg 不含 BT 刀把之重量

卡式刀座

訂購編號	Part No.	Type	螺絲	扳手	刀片
99511-00A	SSFER-D25	SEHW1204	NS-45095	T15	薄板專用卡座
99511-05A	STGCR-D25	TCGT16T3	NS-35080		厚板專用卡座
99511-10A	SSFER0°-D25	SEHW1204	NS-45095		鏡面刀片
99511-20A	SAFPR-D25	APKT1604	NS-35080		8面鋁刀片
99511-39A	SNF9R-D25	99401-467	NS-35080		
99511-41A	SGFGR-D25	N9GJ11T3	NS-35080		

零組件

訂購編號	Part	
NK-TT25	偏心調整扳手	
MS1364	偏心調整螺絲	③
NK-T15	刀片扳手	
99511-00G	定位螺絲	④
99511-00H	調整螺絲護套	②
99511-00I	M8 固定螺絲	⑥

- (1) A. 調整時先以 Z 軸設定器放置於刀片下方
- B. 尋找四刃之中間尺寸作歸零
- C. 其餘調整到歸零位置
 - 1). 先放鬆 M8 固定螺絲半圈
 - 2). 用 DT25 扳手調整偏心螺絲上下
 - 3). 歸零後再鎖緊 M8 固定螺絲

(2) 鑽石刀片設計方法：

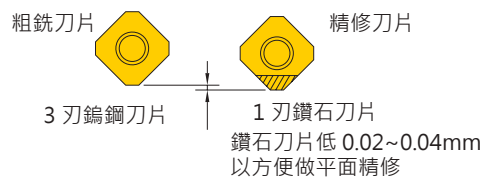

- ★ 鑽石刀片現貨庫存 SEHW1204DM
- ★ 配備 BT40 刀把之機台 · 可用 99511-315 之刀頭作鋁材大平面加工。
- ★ 刀具史上難得佳作 · 同一本體 · 可配多種刀片 · 正反轉切削 · 只需更換卡式刀座。
- ★ 雙面同時銑削用 · 鋼製刀頭正轉型 · 反轉型 · 接受特殊訂製 · 效果奇佳。

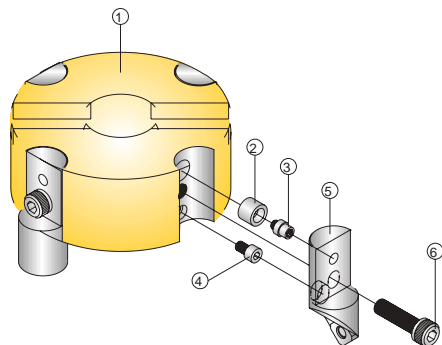

鏡面加工 (面銑)

專利號 US 7,431,541 B2

表面精度可達到鏡面要求
(Ra 0.10 μ m) 以下



刀片名稱	加工線速 m/min	每刃進給 mm/t	預留量 mm	表面精度 (Ra) μ m
N9MT11T3HR300	1000	0.1	0.05	0.056
N9MT11T3HR300	1000	0.2	0.05	0.092
SEHW1204	1000	0.1	0.10	0.800

▶ 鋁刀頭

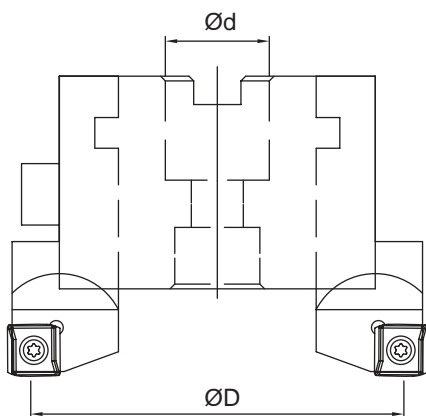

99511-39A
N9MT11T3HR300 NC9031

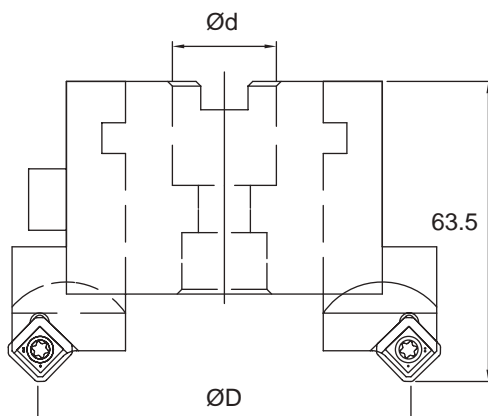

99511-41A
N9GJ11T3F2 NC2033 (鋁用)

訂購編號	Part No.	ØD	Ød	No. of teeth	Kg
99511-080	99511-080-039A 99511-080-041A	80	22	4	1.1
99511-100	99511-100-039A 99511-100-041A	100	22	4	1.4
99511-125	99511-125-039A 99511-125-041A	125	38.1	4	2.1
99511-160	99511-160-039A 99511-160-041A	160	38.1	4	2.9
99511-200	99511-200-039A 99511-200-041A	200	38.1	4	4.2
99511-250	99511-250-039A 99511-250-041A	250	38.1	4	6.5
99511-315	99511-315-039A 99511-315-041A	315	38.1	6	8.0

7

刀霸系列 | 鋁刀頭

E銑刀

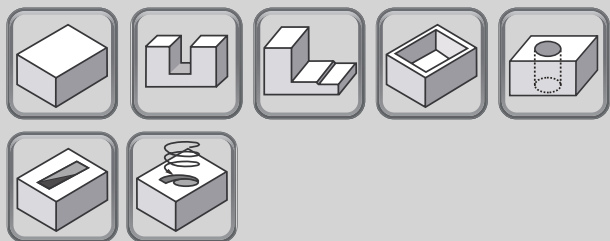

▶ 刀片

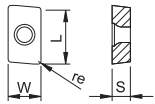
訂購編號		尺寸				螺絲	扳手
		lc	S	Re	W		
N9FX0602-NC10		6.35	2.38	0.4	-	NS-25045 0.9Nm	NK-T7
N9FX09T3-NC10		9.52	3.18	0.4	-	NS-35070 (短) 2.5Nm	NK-T15
N9FX1204-NC10		12.7	4.78	0.8	-	NS-40090 (短) 3.5Nm	
N9FX1604-NC10		L	S	Re	W	NS-35080 2.5Nm	NK-T15
		16	4.78	0.8	9.52		

切削資料

工件材質	加工狀況	材質	Vc (m/min.)	fz (mm / tooth)
N 銅、銅合金 鋁、鋁合金	鑽銑	NC10	200(150~300)	0.10(0.08~0.12)
	開槽	NC10	200(150~300)	0.40(0.15~0.80)
	肩銑	NC10	200(150~300)	0.40(0.15~0.80)

7

刀霸系列 E銑刀

E 銑刀

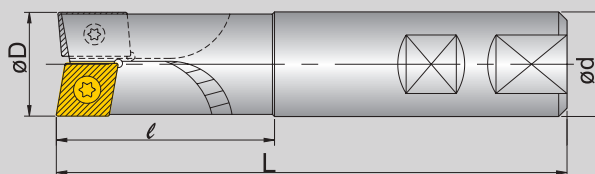

▶ 刀桿

訂購編號	Part No.	ØD	Ød	ℓ	L	適用刀片
99617-14	SB16-EM14	14	16	40	90	N9FX0602-NC10X2
99617-20	SB20-EM20	20	20	50	100	N9FX0602-NC10X1
99617-20L	SB20-EM20L	20	20	80	130	N9FX09T3-NC10X1
99617-25	SB25-EM25	25	25	50	120	N9FX1204-NC10X1
99617-25L	SB25-EM25L	25	25	80	150	N9FX1604-NC10X1

▶ 應用

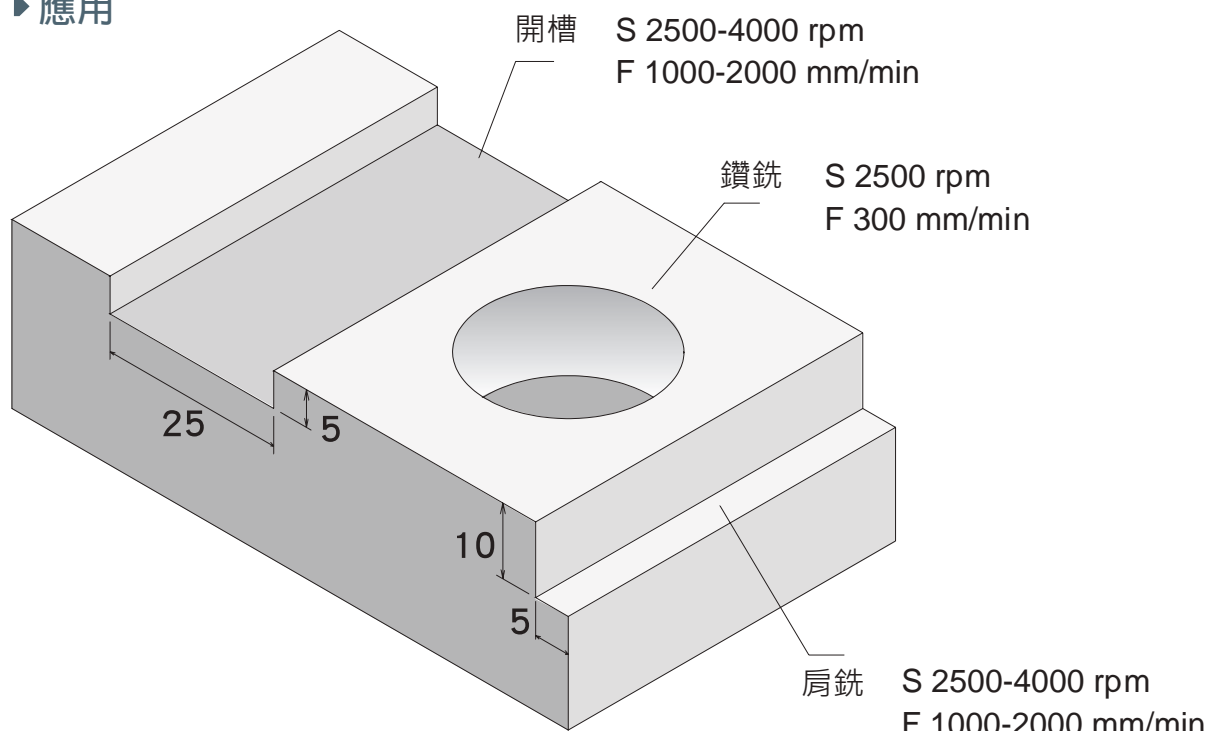

新世紀 (高速切削時代) 新刀具 -E 銑刀 (E Mill)

在模具加工中電極銅、鋁合金加工有著重要的地位，電極粗中胚加工以往以粗銑刀來做加工，轉速慢、進給慢 (F300~400)，且無法預留較小之輪廓預留量，增加了精加工之時間，如今 E 銑刀解決了這些困擾，高轉速 (2500~4000)，高進給 (F2000~F3000) 可減少精加工輪廓預留量，讓您體會到削銅如泥、子彈般切屑的快感，真棒，再告訴您一個小秘密本產品專利在案哦！



專利號: US 7,455,487 B2

高速搪刀 >>>

Cycle Time Roughness Position Accuracy True Roundness

間隙式搪刀和萬轉搪刀都是採用偏心原理，來作搪孔尺寸的微調，因此調整時，不會產生背隙。

P M K N H

- ▶ 容易調整
- ▶ 高效率
- ▶ 低成本



Features >>>

▶ 萬轉搪刀:

- **99101系列:** 0.03mm/div · 調整範圍 ±0.5mm · 尺寸範圍 \varnothing 7mm ~ \varnothing 52mm
- **99121系列:** 0.01mm/div · 調整範圍 ±0.1mm · 尺寸範圍 \varnothing 5mm ~ \varnothing 52mm
- **99146系列:** 0.01mm/div · 調整範圍 ±0.12mm · 動平衡 G6.3 10,000 rpm
尺寸範圍 \varnothing 5mm ~ \varnothing 50mm · 尺寸可自行更換
- **99151系列:** 深孔加工 · 可達4~6xD · 尺寸範圍 \varnothing 1mm ~ \varnothing 20mm

▶ 直接式精搪刀:

本結構主要是利用刀片斜邊角度位置不同，產生直徑方向微量之尺寸變化，此結構應用於單尺寸搪刀，深孔搪刀，特殊搪刀...，可輕易控制 μ 之精度。

- **99021系列:** 直接式微調刀桿
- **99043系列:** 鎖牙型微調刀頭

▶ 微調搪孔頭:

容易調整。高精度容易調整。

- **99148系列:** 0.02mm/div · 游標刻劃2 μ m



Applications

增加回擴尺寸更穩定，
避免迴刀紋



“ 擴刀頭部從5mm到50mm
可更換，更換快速，不影響
動平衡。 ”

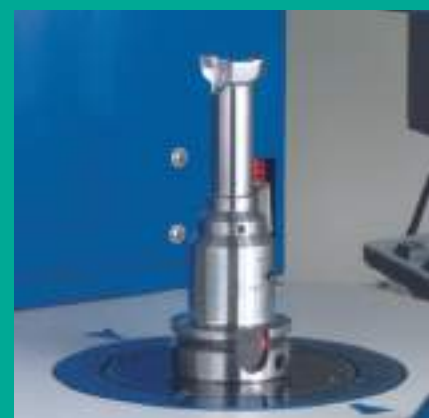

8

高速擴刀

System

龍捲風萬轉搪刀

龍捲風萬轉搪刀

Solid Carbide Shank
99151-xxxxW [page: 8-154](#)

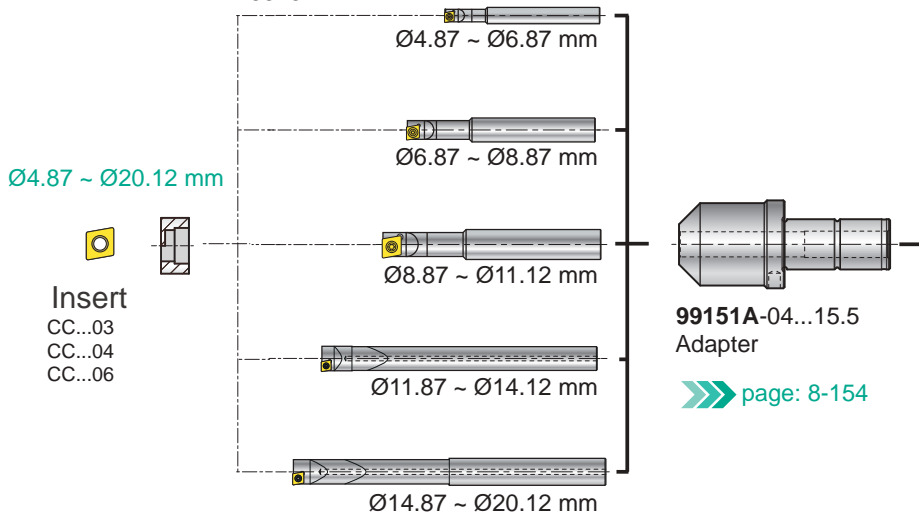

Quick Change
Adjustment boring head shank

ANSI CAT40
DIN 69893 HSK63A
JIS 6339/MAS BT 30/40/50
SB32

Side lock Ø32mm

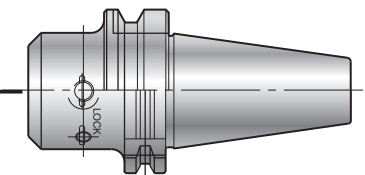

99146-xxxH

[page: 8-150](#)

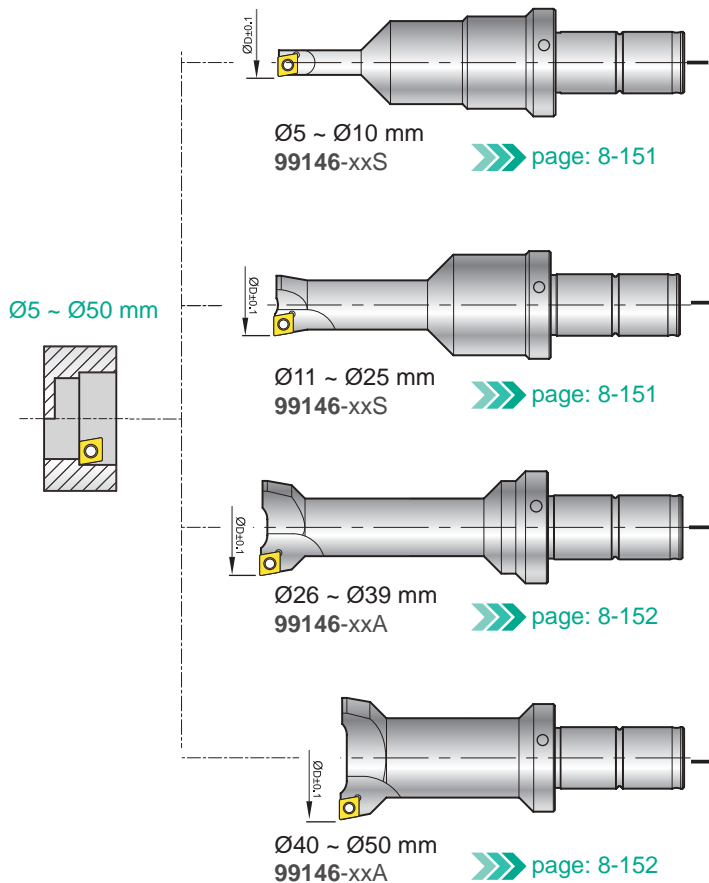

Insert
CC...03
CC...04
CC...06

8

高速搪刀

System

99101 / 99121 間隙式搪刀

刀片

CC...03
CC...04
CC...06

Ø5 ~ Ø52 mm

99101-07...52
99121-05...52

➤➤➤ page: 8-148

側固刀桿
油壓刀桿
筒夾刀桿

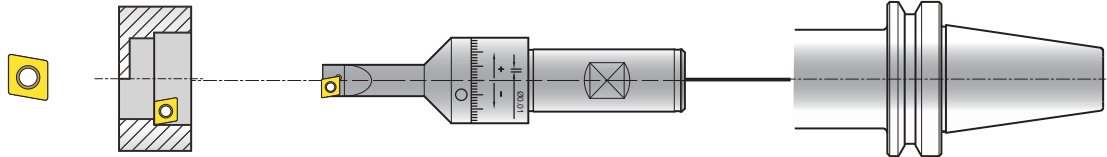

99021 / 99043 直接式微調搪刀

刀片

CC...06
CC...09

Ø14 ~ Ø25 mm

直柄型

99021

➤➤➤ page: 8-158

油壓刀桿
筒夾刀桿



鎖牙型

99043-xx

➤➤➤ page: 8-158

延長桿

鋼柄 / 鎢鋼接桿

99801-xxS / 99801-xxW

➤➤➤ page: 8-158

微調搪孔頭

任何 ISO 刀片

Ø25.7 ~ Ø60.6 mm

CC..06

TC..09

TC..11

TC..16

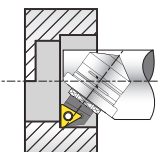

Any available shank

微調搪孔頭

➤➤➤ page: 8-163

8

高速搪刀

99002 低成本4刃口雙刃粗搪刀桿

- N9MT11T308 為專利4 刃口刀片可搪直角盲孔，可用4 刃口，成本下降50%，此刀片還可使用於倒角刀，快速搪頭，特殊暴力鑽，特殊刀具...等，經濟實惠，特殊之邊刃設計，可使進給加倍，表面精度更好。

ISO application



▶ 刀片

訂購編號			尺寸		
			L	S	re
N9MT06T203 鋼材單邊預留小於 1 mm	NC40		6.35	2.78	0.3
N9MT06T203H	NC2033 NC9031				

▶ 刀桿

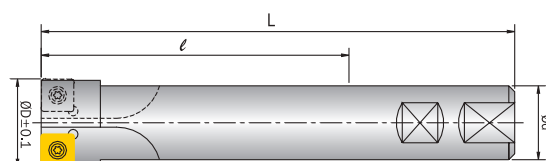

訂購編號	Part No.	ØD	Ød	ℓ	L	刀片	螺絲 / 扳手
99002-015	SB16 - TB15-N9	14.7					
99002-016	SB16 - TB16-N9	15.7					
99002-017	SB16 - TB17-N9	16.7	16	50	98		NS-25045 0.9Nm / NK-T7
99002-018	SB16 - TB18-N9	17.7					
99002-019	SB16 - TB19-N9	18.7	16	62	110	N9MT06T203	
99002-020	SB16 - TB20-N9	19.7					
99002-021	SB16 - TB21-N9	20.7	16	62	110		
99002-022	SB16 - TB22-N9	21.7					NS-25060 0.9Nm / NK-T7
99002-023	SB20 - TB23-N9	22.7	20	70	120		
99002-024	SB20 - TB24-N9	23.7					

▶ 切削資料

	工件材質	加工狀況	刀片材種	線速 Vc (m/min)	二刃進給 (每轉)
P	碳鋼	一般切削	NC40	100 (80~120)	0.20 (0.20~0.40)
	合金鋼	一般切削	NC2033	100 (80~100)	0.20 (0.20~0.30)
M	不鏽鋼	一般切削	NC2033	80 (70~100)	0.20 (0.20~0.30)
K	鑄鐵	一般切削	NC2033	100 (80~120)	0.20 (0.20~0.30)
N	鋁合金	一般切削	NC9031	150 (130~200)	0.20 (0.20~0.40)

刀具轉速 $S = Vc \times 1000 \div 3.14 \div \phi D$ (刀具直徑)

機台進給 $F = \text{轉速} S \times \text{每轉進給} fz$

8

高速搪刀

99002 低成本4刃口雙刃粗搪刀桿

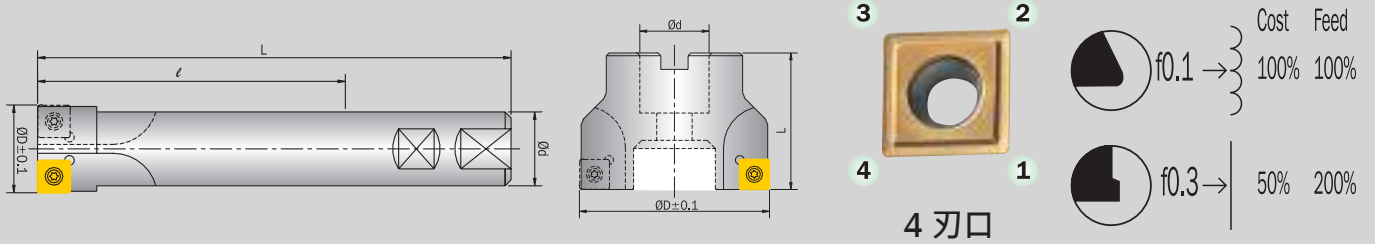

▶ 刀片

訂購編號	NC60 NC40 NC10	尺寸		
		L	S	re
N9MT11T308 斷屑型(一般)		11.11	3.97	0.8
N9MT11T308LA 低阻抗型	NC60 NC40 NC35 NC10	11.11	3.97	0.8

▶ 刀桿

訂購編號	Part No.	ØD	Ød	ℓ	L	刀片	螺絲 / 扳手
99002-025	SB20 - TB25-N9	24.7	20	70	120	N9MT11T308	NS-35080 2.5Nm / NK-T15
99002-026	SB20 - TB26-N9	25.7					
99002-028	SB20 - TB28-N9	27.7					
99002-030	SB25 - TB30-N9	29.7					
99002-032	SB25 - TB32-N9	31.7					
99002-035	SB25 - TB35-N9	34.7	25	104	160		
99002-037	SB25 - TB37-N9	36.7					
99002-040	SB25 - TB40-N9	39.7					
99002-042	SB32 - TB42-N9	41.7					
99002-045	SB32 - TB45-N9	44.7					
99002-047	SB32 - TB47-N9	46.7	32	140	200		
99002-050	SB32 - TB50-N9	49.7					
99002-052	SB42 - TB52-N9	51.7					
99002-055	SB42 - TB55-N9	54.7					
99002-058	SB42 - TB58-N9	57.7					
99002-060	SB42 - TB60-N9	59.7	42	150	220		
99002-062	MC25 - 62-N9	61.7					
99002-065	MC25 - 65-N9	64.7					
99002-070	MC25 - 70-N9	69.7					
99002-080	MC25 - 80-N9	79.7					
99002-090	MC25 - 90-N9	89.7	25.4	-	50		
99002-100	MC25 - 100-N9	99.7					

▶ 切削資料

工件材質	加工狀況	刀片材種	線速 Vc (m/min)	二刃進給 (每轉)
P 碳鋼	一般切削	NC40	100 (80~120)	0.25 (0.20~0.40)
	耐磨鍍層	NC35	120 (100~140)	0.25 (0.20~0.40)
	耐磨(瓷金)	NC60	150 (120~180)	0.20 (0.15~0.25)
合金鋼	一般切削	NC40	100 (80~100)	0.25 (0.20~0.30)
	耐磨鍍層	NC35	120 (100~140)	0.25 (0.20~0.30)
M 不鏽鋼	一般切削	NC40	80 (70~100)	0.25 (0.20~0.30)
K 鑄鐵	一般切削	NC10	100 (80~120)	0.30 (0.25~0.50)
N 鋁合金	一般切削	NC10	150 (130~200)	0.25 (0.20~0.40)

刀具轉速 S = $V_c \times 1000 \div 3.14 \div \phi D$ (刀具直徑)

機台進給 F = 轉速 S X 每轉進給 fz

99011 深孔粗搪刀

▶ 刀片

訂購編號		尺寸		
		lc	S	re
CCMT060204	NC60	6.35	2.38	0.4
	NC40			
	NC10			
CCMT060208	NC40	6.35	2.38	0.8
CCMT060204S (單邊預留0.3mm以下)	NC35	6.35	2.38	0.4
CCFT060204	NC2033	6.35	2.38	0.4
	NC9036			
CCFW060204	NC2032	6.35	2.38	0.4
CCMT09T304	NC60	9.52	3.97	0.4
	NC40			
	NC10			
CCMT09T308	NC40	9.52	3.97	0.8
	NC10			
CCGT09T304HP (鋁合金)	NC10	9.52	3.97	0.4
	K10			

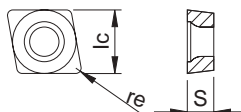
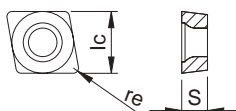

▶ 刀桿

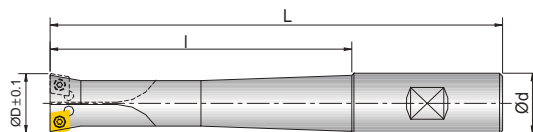

訂購編號	Part No.	ØD	Ød	ℓ	L	刀片	螺絲 / 扳手
99011-16	SB20 - TB16L	15.7	20	70	120	CC..060204	NS-25060 0.9Nm / NK-T7
99011-20	SB20 - TB20L	19.7	20	100	150		
99011-25	SB25 - TB25L	24.7	25	110	166		
99011-30	SB25 - TB30L	29.7	25	134	190	CC..09T30..	NS-35080 2.5Nm / NK-T15
99011-35	SB32 - TB35L	34.7	32	170	230		
99011-40	SB32 - TB40L	39.7	32	190	250		

▶ 切削資料

	工件材質	加工狀況	刀片材種	線速 Vc (m/min)	二刃進給 (每轉)
P	碳鋼	需五彩亮面 (瓷金)	NC60	150 (120~180)	0.15 (0.10~0.20)
		一般切削	NC40, NC2033	100 (80~120)	0.10 (0.08~0.12)
		強制斷屑	NC35	120 (80~150)	0.15 (0.10~0.20)
	合金鋼	一般切削	NC40, NC2033	80 (60~100)	0.15 (0.10~0.20)
M	不鏽鋼	一般切削	NC40, NC2033	100 (80~120)	0.12 (0.10~0.15)
K	鑄鐵	耐磨鍍層	NC10, NC2032	150 (100~180)	0.15 (0.10~0.20)
N	鋁合金	一般切削	NC9036	200 (150~300)	0.20 (0.10~0.30)

刀具轉速 S = Vc x 1000 ÷ 3.14 ÷ ØD (刀具直徑)

機台進給 F = 轉速 S X 每轉進給 fz

8

高速搪刀

應用範例

機車引擎側蓋加工:

加工材料：ADC-12 (A383) 壓鑄件
機器主軸：BT40

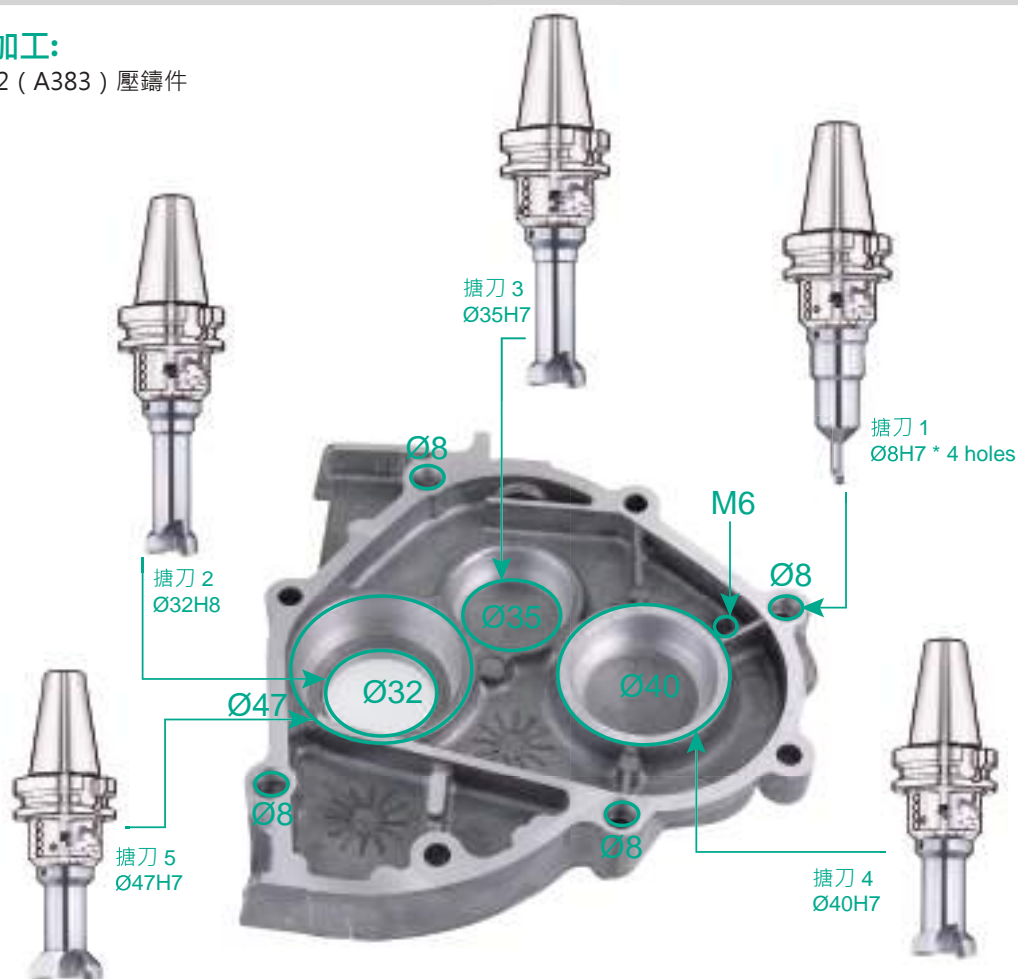

使用Nine9搪刀的刀具清單：

搪刀	搪刀頭	刀片材質	直徑 mm	深度	r.p.m.	F = mm/min.	加工時間
1	99146-08A	CCGT040102 NC30	Ø8H7	8 mm	8000	400	1.2 秒
2	99146-32A	CCFT060204HP NC9031	Ø32H8	8 mm	2985	209	2.3 秒
3	99146-35A		Ø35H7	12 mm	2730	191	3.8 秒
4	99146-40A		Ø40H7	15 mm	2400	168	5.4 秒
5	99146-47A		Ø47H7	15 mm	2030	142	6.4 秒

表面粗糙度範例:

工件材質	Vc m/min.	f mm/rev.	表面粗糙度			刀桿	刀片
			Ra	Rz	Rmax		
Al alloy, 6061	150	0.2	0.076µm	0.50µm	0.6µm	99146-BT40-26A	CCGH0602U NC9096

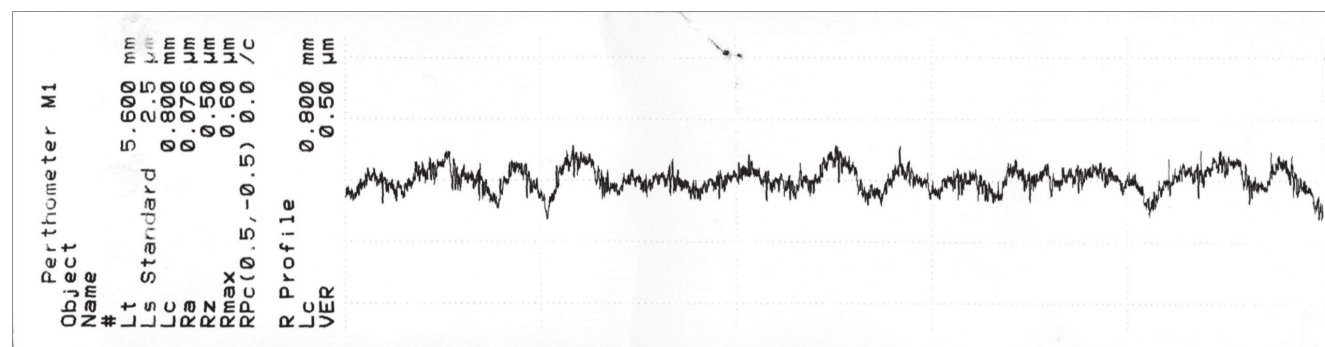

8

高速搪刀

99101 間隙式粗搪刀 - 0.03 mm/div.



尺寸範圍:
6.5mm ~ 52.5mm

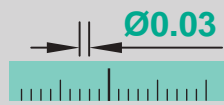

0.03mm/div
可在刀具設定儀
預先調尺寸

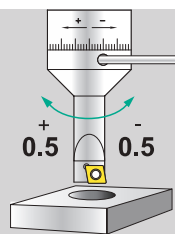

調整範圍±0.5mm.

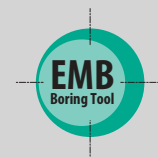

尺寸調整時
不用消除背隙

容易操作

- 最小刻劃0.03mm/div · 調整容易

經濟型

- 低成本可取代端銑刀或搪孔刀桿
- 更換刀片可切削各種不同材料

應用

- 容易作精搪孔前的穩定粗搪
- 精準的粗搪孔
- 可在銑床 · 切削中心機 · 特殊專用機上使用

ISO application

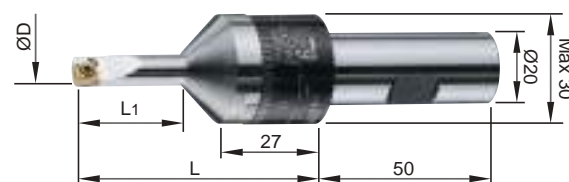

- * 可依加工需求訂購中心出水型頭部。
- * 可接受特殊規格訂製。

訂購編號	Part No.		ØD	L1	L	刀片	螺絲 / 扳手
99101-07	SB20-0721-03		6.5 - 7.5	21	60	CC...040102	NS-20036 0.6Nm / NK-T6
99101-08	SB20-0824-03		7.5 - 8.5	24	63		
99101-09	SB20-0927-03		8.5 - 9.5	27	65	CC...060204	NS-25045 0.9Nm / NK-T7
99101-10	SB20-1030-03		9.5 - 10.5	30	68		
99101-11	SB20-1133-03		10.5 - 11.5	33	70		
99101-12	SB20-1236-03		11.5 - 12.5	36	73		
99101-13	SB20-1339-03		12.5 - 13.5	39	75		
99101-14	SB20-1442-03		13.5 - 14.5	42	78		
99101-15	SB20-1545-03		14.5 - 15.5	45	80		
99101-16	SB20-1648-03		15.5 - 16.5	48	83		
99101-17	SB20-1751-03		16.5 - 17.5	51	85		
99101-18	SB20-1850-03		17.5 - 18.5	50	82		
99101-19	SB20-1950-03		18.5 - 19.5	50	82	CC...060204	NS-25060 0.9Nm / NK-T7
99101-20	SB20-2050-03		19.5 - 20.5	50	82		
99101-21	SB20-2150-03	Adjustment range:±0.5mm	20.5 - 21.5	50	82		
99101-22	SB20-2250-03		21.5 - 22.5	50	82		
99101-23	SB20-2350-03	Each Division 0.03mm	22.5 - 23.5	50	82		
99101-24	SB20-2450-03		23.5 - 24.5	50	82		
99101-25	SB20-2550-03		24.5 - 25.5	50	82		
99101-26	SB20-2650-03		25.5 - 26.5	50	82		
99101-27	SB20-2750-03		26.5 - 27.5	50	82		
99101-28	SB20-2850-03		27.5 - 28.5	50	82		
99101-29	SB20-2950-03		28.5 - 29.5	50	82		
99101-30	SB20-3050-03		29.5 - 30.5	50	82		
99101-32	SB20-3250-03		31.5 - 32.5	50	82		
99101-35	SB20-3550-03		34.5 - 35.5	50	82		
99101-37	SB20-3750-03		36.5 - 37.5	50	82		
99101-40	SB20-4050-03		39.5 - 40.5	50	82		
99101-42	SB20-4250-03		41.5 - 42.5	50	82		
99101-45	SB20-4530-03		44.5 - 45.5	23	50		
99101-47	SB20-4730-03		46.5 - 47.5	23	50		
99101-50	SB20-5030-03		49.5 - 50.5	23	50		
99101-52	SB20-5230-03		51.5 - 52.5	23	50		

8

高速搪刀

99121 間隙式精搪刀 - 0.01 mm/div.



尺寸範圍:
4.9mm ~ 52.1mm



0.01mm/div
可在刀具設定儀
預先調尺寸

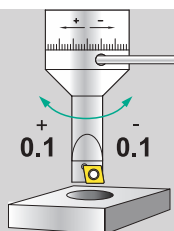

調整範圍±0.1mm.



尺寸調整時
不用消除背隙

容易操作

- 最小刻劃0.01mm/div · 調整容易

經濟型

- 低成本可取代端銑刀或搪孔刀桿
- 更換刀片可切削各種不同材料

應用

- 精準的精搪孔
- 可在銑床 · 切削中心機 · 特殊專用機上使用

ISO application

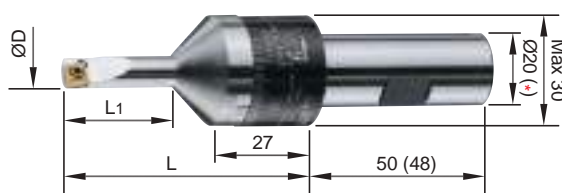

- * 可依加工需求訂購中心出水型頭部。
- * 可接受特殊規格訂製。

* 另有柄徑Ø13/Ø16可供選擇。

訂購編號	Part No.		ØD	L1	L	刀片	螺絲 / 扳手
99121-05	SB20-0515-01		4.9 - 5.1	15	54	CC...030102	NS-16030
99121-06	SB20-0618-01		5.9 - 6.1	18	57		0.4Nm / NK-T6
99121-07	SB20-0721-01		6.9 - 7.1	21	60		
99121-08	SB20-0824-01		7.9 - 8.1	24	63	CC...040102	NS-20036
99121-09	SB20-0927-01		8.9 - 9.1	27	65		0.6Nm / NK-T6
99121-10	SB20-1030-01		9.9 - 10.1	30	68		
99121-11	SB20-1133-01		10.9 - 11.1	33	70		
99121-12	SB20-1236-01		11.9 - 12.1	36	73	CC...060204	NS-25045
99121-13	SB20-1339-01		12.9 - 13.1	39	75		0.9Nm / NK-T7
99121-14	SB20-1442-01		13.9 - 14.1	42	78		
99121-15	SB20-1545-01		14.9 - 15.1	45	80		
99121-16	SB20-1648-01		15.9 - 16.1	48	83		
99121-17	SB20-1751-01		16.9 - 17.1	51	85		
99121-18	SB20-1850-01		17.9 - 18.1	50	82		
99121-19	SB20-1950-01		18.9 - 19.1	50	82		
99121-20	SB20-2050-01	Adjustment range:±0.1mm	19.9 - 20.1	50	82		
99121-21	SB20-2150-01		20.9 - 21.1	50	82		
99121-22	SB20-2250-01	Each Division 0.01mm	21.9 - 22.1	50	82		
99121-23	SB20-2350-01		22.9 - 23.1	50	82		
99121-24	SB20-2450-01		23.9 - 24.1	50	82		
99121-25	SB20-2550-01		24.9 - 25.1	50	82		
99121-26	SB20-2650-01		25.9 - 26.1	50	82		
99121-27	SB20-2750-01		26.9 - 27.1	50	82		
99121-28	SB20-2850-01		27.9 - 28.1	50	82	CC...060204	NS-25060
99121-29	SB20-2950-01		28.9 - 29.1	50	82		0.9Nm / NK-T7
99121-30	SB20-3050-01		29.9 - 30.1	50	82		
99121-32	SB20-3250-01		31.9 - 32.1	50	82		
99121-35	SB20-3550-01	34.9 - 35.1	50	82			
99121-37	SB20-3750-01	36.9 - 37.1	50	82			
99121-40	SB20-4050-01	39.9 - 40.1	50	82			
99121-42	SB20-4250-01	41.9 - 42.1	50	82			
99121-45	SB20-4530-01	44.9 - 45.1	23	50			
99121-47	SB20-4730-01	46.9 - 47.1	23	50			
99121-50	SB20-5030-01	49.9 - 50.1	23	50			
99121-52	SB20-5230-01	51.9 - 52.1	23	50			



高速搪刀

99146 龍捲風萬轉搪刀



尺寸範圍:
4.87mm ~ 50.12mm



0.01mm/div
可在刀具設定儀
預先調尺寸



調整範圍
+0.12 / -0.13mm.



動平衡
G6.3 10000 r.p.m

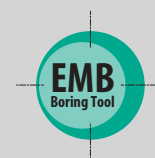

尺寸調整時
不用消除背隙

容易操作

- 尺寸調整容易，可在刀具設定儀預先調尺寸或在切削中心機上直接調整
- 尺寸調整時，不用消除背隙
- 更換頭部快速，尺寸變換容易

低成本的小孔徑精搪刀

- 比其他精搪刀更經濟

搪刀頭部從5mm到50mm可更換

- 頭部尺寸齊全，更換快速，不影響動平衡

高轉速

- 高轉速設計，動平衡G6.3 10,000rpm
- 階級孔，加倒角，加平面特殊搪刀頭部可訂製

▶ 微調搪刀柄

• HSK63

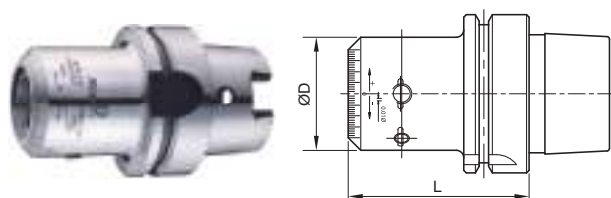

• CAT40

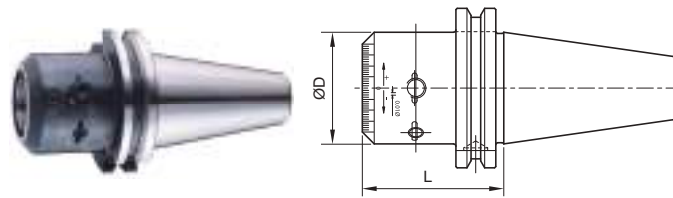

• BT

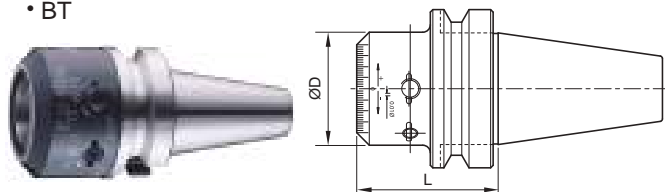

• SB32

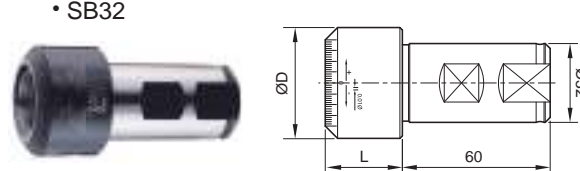

8

高速搪刀

訂購編號	Part No.	ØD	L
99146-HSK63AH	HSK63A-146-72	45	72
99146-CAT40H	CAT40-146-56	45	56.3
99146-BT30H	BT30-146-51	45	51.3
99146-BT40H	BT40-146-56	45	56.3
99146-BT50H	BT50-146-77	45	77.3
99146-SB32H	SB32-146-31	45	31.3

99146 龍捲風萬轉搪刀

▶ 搪刀頭部 Ø5~Ø25

- 高合金鋼頭部
- 搪孔深度：L1, 2 ~ 3xD

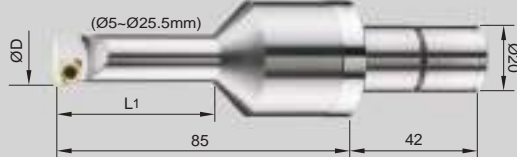

- * 可依加工需求訂購中心出水型頭部。
- * 可訂製特殊規格。

ISO application



訂購編號	Part No.	ØD	L1	刀片/螺絲/扳手	訂購編號	Part No.	ØD	L1	刀片/螺絲/扳手
99146-0500S	C20-0500-10L	4.87~5.12	10.00	CC...030102 NS-16030 0.4Nm / NK-T6	99146-1725S	C20-1725-42L	17.12~17.37	42.50	CC...060204 螺絲: NS-25045 0.9Nm 扳手: NK-T7
99146-0600S	C20-0600-12L	5.87~6.12	12.00		99146-1750S	C20-1750-43L	17.37~17.62	43.75	
99146-0700S	C20-0700-14L	6.87~7.12	14.00		99146-1775S	C20-1775-43L	17.62~17.87	43.75	
99146-0800S	C20-0800-16L	7.87~8.12	16.00		99146-1800S	C20-1800-45L	17.87~18.12	45.00	
99146-0900S	C20-0900-18L	8.87~9.12	18.00		99146-1825S	C20-1825-45L	18.12~18.37	45.00	
99146-1000S	C20-1000-25L	9.87~10.12	25.00		99146-1850S	C20-1850-46L	18.37~18.62	46.25	
99146-1025S	C20-1025-25L	10.12~10.37	25.00		99146-1875S	C20-1875-46L	18.62~18.87	46.25	
99146-1050S	C20-1050-26L	10.37~10.62	26.25		99146-1900S	C20-1900-47L	18.87~19.12	47.50	
99146-1075S	C20-1075-26L	10.62~10.87	26.25		99146-1925S	C20-1925-47L	19.12~19.37	47.50	
99146-1100S	C20-1100-27L	10.87~11.12	27.50		99146-1950S	C20-1950-48L	19.37~19.62	48.75	
99146-1125S	C20-1125-27L	11.12~11.37	27.50		99146-1975S	C20-1975-48L	19.62~19.87	48.75	
99146-1150S	C20-1150-28L	11.37~11.62	28.75		99146-2000S	C20-2000-50L	19.87~20.12	50.00	
99146-1175S	C20-1175-28L	11.62~11.87	28.75		99146-2025S	C20-2025-50L	20.12~20.37	50.00	
99146-1200S	C20-1200-30L	11.87~12.12	30.00		99146-2050S	C20-2050-50L	20.37~20.62	50.00	
99146-1225S	C20-1225-30L	12.12~12.37	30.00		99146-2075S	C20-2075-50L	20.62~20.87	50.00	
99146-1250S	C20-1250-31L	12.37~12.62	31.25		99146-2100S	C20-2100-50L	20.87~21.12	50.00	
99146-1275S	C20-1275-31L	12.62~12.87	31.25		99146-2125S	C20-2125-50L	21.12~21.37	50.00	
99146-1300S	C20-1300-32L	12.87~13.12	32.50	99146-2150S	C20-2150-50L	21.37~21.62	50.00		
99146-1325S	C20-1325-32L	13.12~13.37	32.50	99146-2175S	C20-2175-50L	21.62~21.87	50.00		
99146-1350S	C20-1350-33L	13.37~13.62	33.75	99146-2200S	C20-2200-50L	21.87~22.12	50.00		
99146-1375S	C20-1375-33L	13.62~13.87	33.75	99146-2225S	C20-2225-50L	22.12~22.37	50.00		
99146-1400S	C20-1400-35L	13.87~14.12	35.00	99146-2250S	C20-2250-50L	22.37~22.62	50.00		
99146-1425S	C20-1425-35L	14.12~14.37	35.00	99146-2275S	C20-2275-50L	22.62~22.87	50.00		
99146-1450S	C20-1450-36L	14.37~14.62	36.25	99146-2300S	C20-2300-50L	22.87~23.12	50.00		
99146-1475S	C20-1475-36L	14.62~14.87	36.25	99146-2325S	C20-2325-50L	23.12~23.37	50.00		
99146-1500S	C20-1500-37L	14.87~15.12	37.50	99146-2350S	C20-2350-50L	23.37~23.62	50.00		
99146-1525S	C20-1525-37L	15.12~15.37	37.50	99146-2375S	C20-2375-50L	23.62~23.87	50.00		
99146-1550S	C20-1550-38L	15.37~15.62	38.75	99146-2400S	C20-2400-50L	23.87~24.12	50.00		
99146-1575S	C20-1575-38L	15.62~15.87	38.75	99146-2425S	C20-2425-50L	24.12~24.37	50.00		
99146-1600S	C20-1600-40L	15.87~16.12	40.00	99146-2450S	C20-2450-50L	24.37~24.62	50.00		
99146-1625S	C20-1625-40L	16.12~16.37	40.00	99146-2475S	C20-2475-50L	24.62~24.87	50.00		
99146-1650S	C20-1650-41L	16.37~16.62	41.25	99146-2500S	C20-2500-50L	24.87~25.12	50.00		
99146-1675S	C20-1675-41L	16.62~16.87	41.25	99146-2525S	C20-2525-50L	25.12~25.37	50.00		
99146-1700S	C20-1700-42L	16.87~17.12	42.50	99146-2550S	C20-2550-50L	25.37~25.62	50.00		



高速搪刀

99146 龍捲風萬轉搪刀

▶ 搪刀頭部 Ø26~Ø50

- 高合金鋼頭部
- 搪孔深度：L1, 2 ~ 3xD

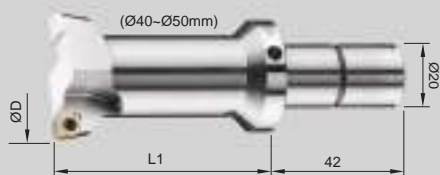
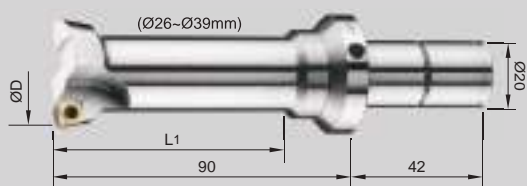

▶ Ø26~Ø39mm

* 可依加工需求訂購中心出水型頭部。

訂購編號	Part No.	ØD	L1	刀片/螺絲/ 扳手
99146-26A	C20-2600-50L	25.87~26.12	50.00	CC..060204 螺絲: NS-25060 扳手: NK-T7
99146-27A	C20-2700-50L	26.87~27.12	50.00	
99146-28A	C20-2800-50L	27.87~28.12	50.00	
99146-29A	C20-2900-50L	28.87~29.12	50.00	
99146-30A	C20-3000-50L	29.87~30.12	50.00	
99146-31A	C20-3100-70L	30.87~31.12	70.00	
99146-32A	C20-3200-70L	31.87~32.12	70.00	
99146-33A	C20-3300-70L	32.87~33.12	70.00	
99146-34A	C20-3400-70L	33.87~34.12	70.00	
99146-35A	C20-3500-70L	34.87~35.12	70.00	
99146-36A	C20-3600-70L	35.87~36.12	70.00	
99146-37A	C20-3700-70L	36.87~37.12	70.00	
99146-38A	C20-3800-70L	37.87~38.12	70.00	
99146-39A	C20-3900-70L	38.87~39.12	70.00	

▶ Ø40~Ø50mm

* 可依加工需求訂購中心出水型頭部。

訂購編號	Part No.	ØD	L1	刀片/螺絲/ 扳手
99146-40A	C20-4000-70L	39.87-40.12	70.00	CC..060204 螺絲: NS-25060 扳手: NK-T7
99146-41A	C20-4100-70L	40.87-41.12	70.00	
99146-42A	C20-4200-70L	41.87-42.12	70.00	
99146-43A	C20-4300-70L	42.87-43.12	70.00	
99146-44A	C20-4400-70L	43.87-44.12	70.00	
99146-45A	C20-4500-70L	44.87-45.12	70.00	
99146-46A	C20-4600-70L	45.87-46.12	70.00	
99146-47A	C20-4700-70L	46.87-47.12	70.00	
99146-48A	C20-4800-70L	47.87-48.12	70.00	
99146-49A	C20-4900-70L	48.87-49.12	70.00	
99146-50A	C20-5000-70L	49.87-50.12	70.00	

▶ 套組

訂購編號	內容
99146-BT30-05SET	BT30H 微調搪刀柄
99146-BT40-05SET	BT40H 微調搪刀柄
99146-BT50-05SET	BT50H 微調搪刀柄
99146-CAT40-05SET	CAT40H 微調搪刀柄
99146-HSK63A-05SET	HSK63A 微調搪刀柄

微調搪刀柄: 1支
 搪刀頭部: Ø5~Ø50 任何 5 支
 配件: 3~5 支

• 注意: 套組不包含刀片, 請分開訂購。

8

高速搪刀

99146 龍捲風萬轉搪刀 - 組裝流程



1. 用4mm扳手鬆開M8螺絲，不用取出螺絲
2. 用3mm扳手鬆開M6螺絲，不用取出螺絲
3. 取下舊頭部，更換新尺寸的頭部
4. 鎖緊M6預壓螺絲，扭力設定0.9 – 1.0Nm
5. 刀具設定儀預先調尺寸
6. 鎖緊M8鎖固螺絲，扭力設定8-9 Nm

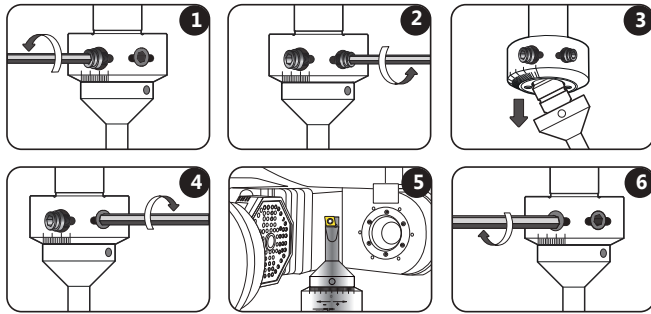

- 尺寸調整步驟

在刀具設定儀

1. 鬆開M8螺絲
2. 設定頭部在中間位置 (Step 1)
3. 量測尺寸值，並設定需要的尺寸 (Step 2)
4. 試加工後，依據所需的尺寸作調整 (Step 3, 4)
5. 鎖固M8螺絲

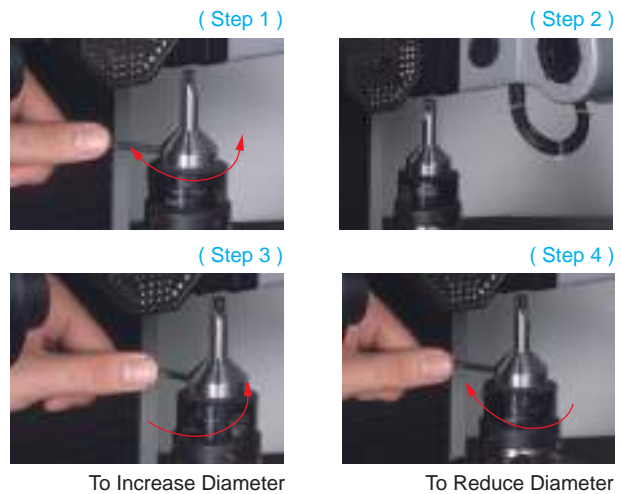

在切削中心機或銑床上

的調整方式

1. 設定在所需尺寸位置 (Step 1)
2. 鎖固M8螺絲
3. 先試搪一個孔，3 ~ 5mm深
4. 量測加工尺寸
5. 根據加工尺寸大小，作尺寸調整 (Step 2, 3)
6. 鎖緊M8鎖固螺絲 (Step 4)

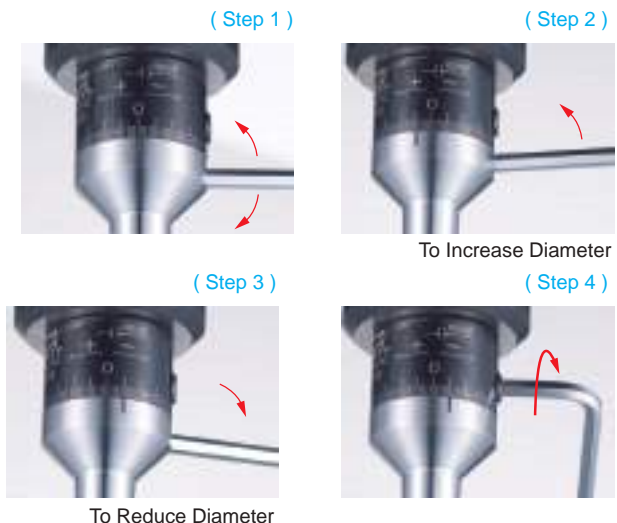

8

高速搪刀

99151深孔搪刀 4 ~ 6xD

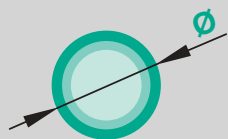

尺寸範圍:
4.87mm ~ 20.12mm

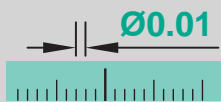

0.01mm/div
可在刀具設定儀
預先調尺寸



調整範圍
+0.12 / -0.13mm.

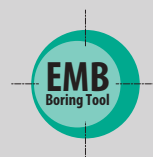

尺寸調整時
不用消除背隙

容易操作

- 4 ~ 6xD加工深度 · 動平衡良好

經濟實惠

- 低成本 · 高效率 · 可取代端銑刀、搪孔刀
- 更換刀片可切削各種不同材種

應用

- 取代端銑刀 · 尤其是小孔徑搪孔
- 電子零件 · 精密零組件加工

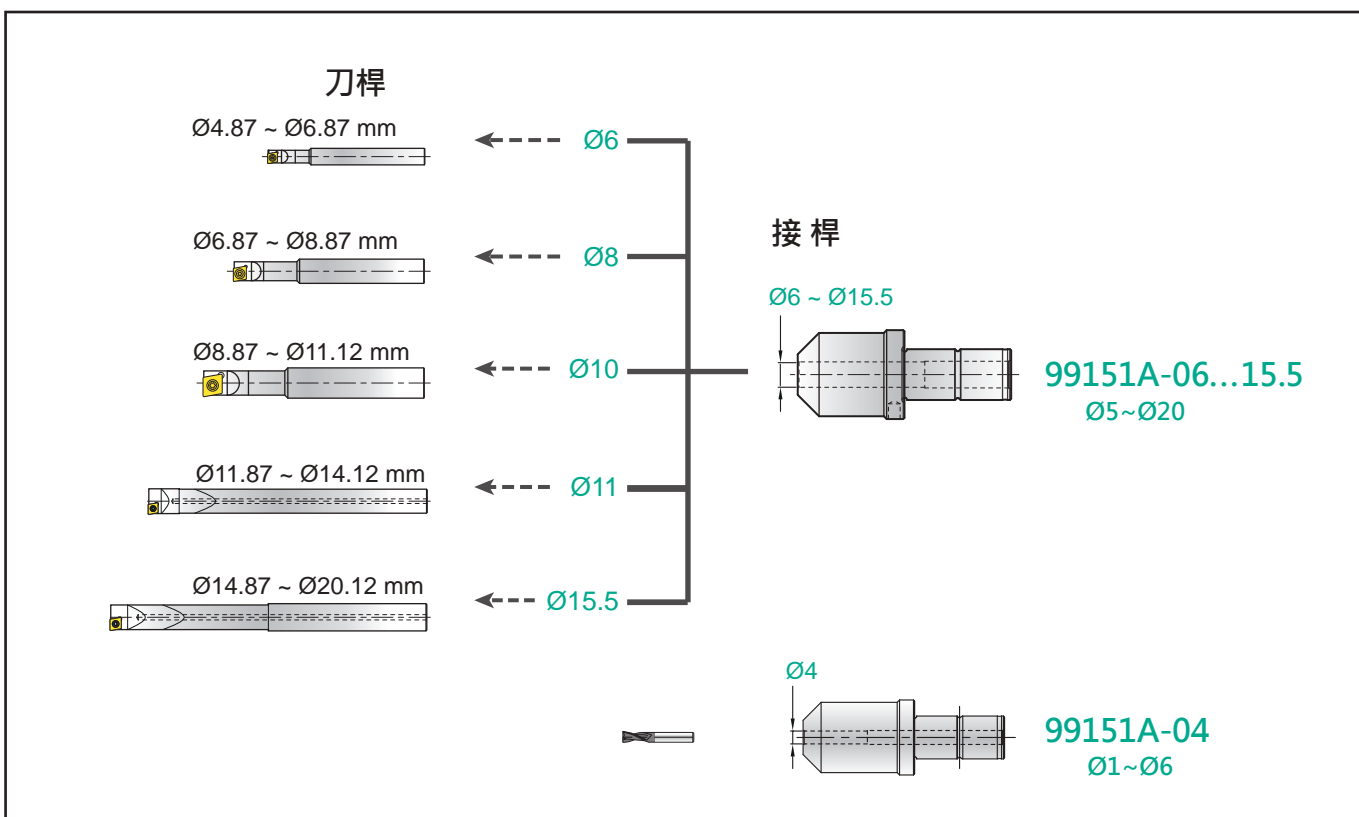

8

高速搪刀

99151 龍捲風萬轉搪刀

▶ 接桿

• 搪孔刀經濟型解決方案



訂購編號	Part No.	ØD	L
99151A-04	C20-ID04	4	49
99151A-06	C20-ID06	6	52
99151A-08	C20-ID08	8	49
99151A-10	C20-ID10	10	42
99151A-11	C20-ID11	11	21.5
99151A-15.5	C20-ID15.5	15.5	21.5

▶ 鎢鋼刀桿 Ø5~Ø20

• 搪孔深度：L1, 4~6xD

訂購編號	Part No.	ØD	Ød	Ød1	L1	L	刀片/螺絲/扳手	Fig.
99151-0500W	C06-0500-20L	4.87~5.12	6	-	20.00	70	CCGT030102 螺絲: NS-16030 0.4Nm 扳手:NK-T6	
99151-0525W	C06-0525-20L	5.12~5.37	6	-	20.00	70		
99151-0550W	C06-0550-22L	5.37~5.62	6	-	22.00	70		
99151-0575W	C06-0575-22L	5.62~5.87	6	-	22.00	70		
99151-0600W	C06-0600-24L	5.87~6.12	6	-	24.00	70		
99151-0625W	C06-0625-24L	6.12~6.37	6	-	24.00	70		
99151-0650W	C06-0650-26L	6.37~6.62	6	-	26.00	70		
99151-0675W	C06-0675-26L	6.62~6.87	6	-	26.00	70		
99151-0700W	C08-0700-28L	6.87~7.12	8	-	28.00	85	CCGT040102 螺絲: NS-20036 0.6Nm 扳手:NK-T6	
99151-0725W	C08-0725-28L	7.12~7.37	8	-	28.00	85		
99151-0750W	C08-0750-30L	7.37~7.62	8	-	30.00	85		
99151-0775W	C08-0775-30L	7.62~7.87	8	-	30.00	85		
99151-0800W	C08-0800-32L	7.87~8.12	8	-	32.00	85		
99151-0825W	C08-0825-32L	8.12~8.37	8	-	32.00	85		
99151-0850W	C08-0850-34L	8.37~8.62	8	-	34.00	85	CC...060204 螺絲: NS-25045 0.9Nm 扳手:NK-T7	
99151-0875W	C08-0875-34L	8.62~8.87	8	-	34.00	85		
99151-0900W	C10-0900-36L	8.87~9.12	10	-	36.00	110		
99151-0925W	C10-0925-36L	9.12~9.37	10	-	36.00	110		
99151-0950W	C10-0950-38L	9.37~9.62	10	-	38.00	110		
99151-0975W	C10-0975-38L	9.62~9.87	10	-	38.00	110		
99151-1000W	C10-1000-40L	9.87~10.12	10	-	40.00	110		
99151-1025W	C10-1025-40L	10.12~10.37	10	-	40.00	110		
99151-1050W	C10-1050-42L	10.37~10.62	10	-	42.00	110	CC...060204 螺絲: NS-25045 0.9Nm 扳手:NK-T7	
99151-1075W	C10-1075-42L	10.62~10.87	10	-	42.00	110		
99151-1100W	C10-1100-44L	10.87~11.12	10	-	44.00	110	CC...060204 螺絲: NS-25045 0.9Nm 扳手:NK-T7	
99151-1200WS	C11-1200-120L	11.87~12.12	11	-	70.00	120		
99151-1300WS	C11-1300-120L	12.87~13.12	11	-	70.00	120		
99151-1400WS	C11-1400-120L	13.87~14.12	11	-	70.00	120		
99151-1500W	C15.5-1500-180L	14.87~15.12	15.5	14	90.00	180	CC...060204 螺絲: NS-25060 0.9Nm 扳手:NK-T7	
99151-1600W	C15.5-1600-180L	15.87~16.12	15.5	15	90.00	180		
99151-1700W	C15.5-1700-180L	16.87~17.12	15.5	-	100.00	180		
99151-1800W	C15.5-1800-180L	17.87~18.12	15.5	-	100.00	180		
99151-1900W	C15.5-1900-180L	18.87~19.12	15.5	-	100.00	180		
99151-2000W	C15.5-2000-180L	19.87~20.12	15.5	-	100.00	180		



高速搪刀

研磨刀片

刀片		敘述	CCGT030102	CCGT040102	CCGW040102	CCGH0602U	CCFT060204	CCFW060204	CCFT060204HP	CCMW060204	
	NC30	K20F、TiAlN鍍層適用於鑄鐵、碳鋼、合金鋼、不鏽鋼	•	•							
	DM	PCD焊刃經拋光處理後，可用於精修表面加工且延長刀具壽命			•					•	
	NC2032	K20F、AlTiN 鍍層、適用於高速加工鑄鐵						•			
	NC2033	K20F、TiAlN鍍層、適用於碳鋼、合金鋼、不鏽鋼					•				
	NC9031	K20F、TiN鍍層、適用於鋁合金、銅及非鐵金屬							•		
	NC9036	K20F、DLC鍍層、壽命長、適用於鋁合金、銅及非鐵金屬	•	•			•				
	U-XP9001	K20F、適用於鋁合金鏡面加工				•					
尺寸:			lc	3.5	4.3	4.3	6.35	6.35	6.35	6.35	6.35
			S	1.4	1.8	1.8	2.38	2.38	2.38	2.38	2.38
			re	0.2	0.2	0.2	-	0.4	0.4	0.4	0.4

切削資料

- Note: Super fine finishing insert **U-XP9001** and **DM** with special specified cutting width **0.15mm**.(Radius)
(see table below)

Spindle speed $S = \frac{V_c \times 1000}{\pi \times D}$ r.p.m. Feed rate: $f \times S$ mm/min.

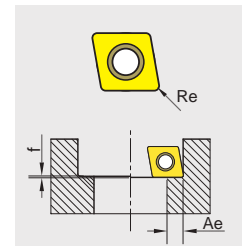

工件材質	Cutting conditions or surface finishes	Grade of insert	Cutting Speed Vc(m/min.)	feed rate f (mm/rev.)	Re0.2	Re0.4
					Ae (mm)	
P 碳鋼	Regular cutting	NC2033	120-150-200	0.05-0.07-0.10	0.05	0.1
	Interrupted cutting	NC30	100-120-140	0.04-0.05-0.08	0.05	0.1
M 合金鋼	Regular cutting	NC2033	100-120-140	0.05-0.07-0.10	0.05	0.1
	Interrupted cutting	NC30	80-100-120	0.04-0.05-0.08	0.05	0.1
K 不鏽鋼	Regular cutting	NC2033	80-100-120	0.05-0.07-0.10	0.05	0.1
	Interrupted cutting	NC30	70-80-100	0.05-0.07-0.10	0.05	0.1
N 鑄鐵	Regular cutting	NC2032 NC30	80-100-120	0.05-0.07-0.10	0.05	0.1
	Regular cutting	NC9036 NC9031	150-200-300	0.05-0.07-0.10	0.05	0.1
	Super mirror finish	U-XP9001	150-200-300	0.15-0.2-0.25	0.05	
N Brass, Bronze and Al-alloy Si >6%	Regular cutting	NC9036 NC9031	150-200-300	0.05-0.07-0.10	0.05	0.1
	Super finished	DM	500-1000-2000	0.05-0.07-0.10	0.05	0.1
	Super mirror finish	U-XP9001	150-200-300	0.15-0.20-0.25	0.05	
H 鋁、鋁合金、非鐵材質	Regular cutting	NC30	80-100-120	0.04-0.06-0.08	0.05	0.1

8

高速搪刀

直接式微調精搪刀



8

高速搪刀

直接式微調精搪刀

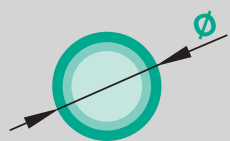

搪孔範圍：
13.9mm ~ 25.1mm



0.01mm/div
可在刀具設定儀
預先調尺寸



調整範圍：
+0.1 / -0.1mm

▶ 直接式微調精搪刀家族

99021:

直柄型微調刀頭

調整範圍 ±0.1,

尺寸範圍 Ø15.9mm~Ø50.1mm.



99043:

鎖固型微調刀頭

調整範圍 ±0.1,

尺寸範圍：Ø13.9mm~Ø25.1mm



▶ 特色

- 利用刀片斜邊，直接推動刀片調整尺寸
- 推動刀片斜邊，產生微量孔徑變化
- 刀片尺寸調整，只能單方向運作

- ① 滑動墊片
- ② 微調螺絲
- ③ 刀片螺絲
- ④ 刀片

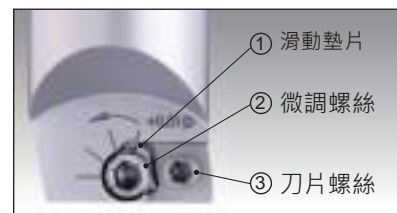
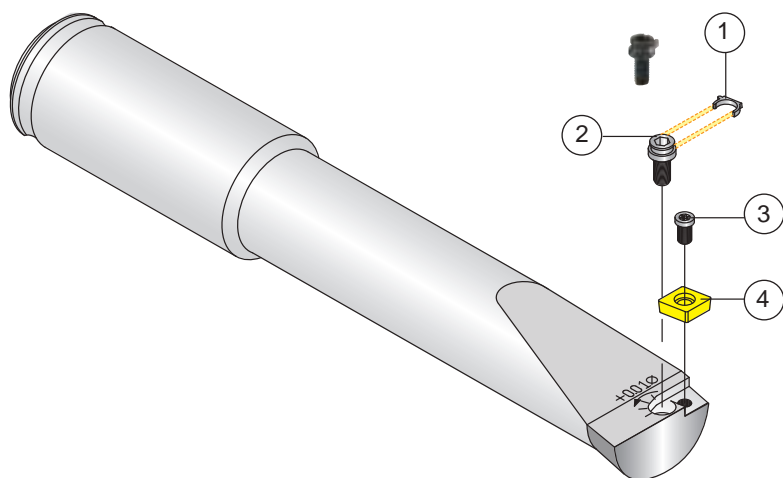

8

高速
搪刀

本專利結構主要是利用刀片斜邊角度位置不同，產生直徑方向微量之尺寸變化，此結構應用於單尺寸搪刀，深孔搪刀，特殊刀具....可輕易控制 μ 之精度，效果卓越。

調整尺寸步驟

• 延長桿增加TIN鍍層，顯示最深加工深度



▶ 在刀具設定儀

1. 打開螺絲2，
順時針鎖到底部
2. 鎖緊刀片螺絲1
3. 將刀具放上刀具設定儀
4. 用刀具設定儀量測尺寸，逆時針調整尺寸
5. 如果調整尺寸太大，請重複用2-4步驟
6. 試加工先搪5mm深
7. 將頭部放刀具設定儀設定尺寸
8. 記取調整尺寸量
9. 試加工後再作調整

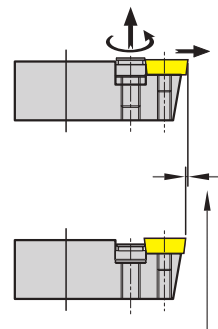
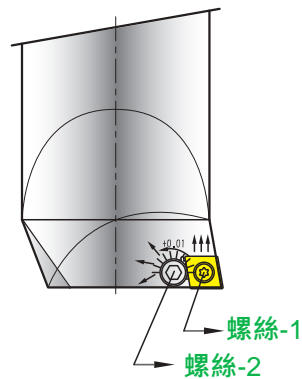

調整範圍 0.2 mm

▶ 在刀具設定儀上調整搪孔直徑



增加搪孔直徑的方向。



8

高速搪刀

99021 直接式微調精搪刀桿

- 直接式搪孔刀桿，强度高，不易振刀，適合銑床，M/C，專用機。
- 配合刀具精準儀使用，精準快速成本低廉。

使用要點：

- 單向調整（逆時鐘方向）。
- 調整尺寸時，刀片螺絲需鎖緊不可放鬆。

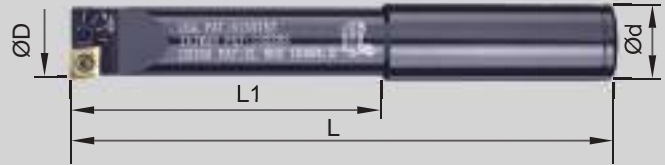

▶ 刀片

訂購編號		尺寸		
		lc	S	re
CCGH060204	NC60	6.35	2.38	0.4
CCFT060204	NC2033	6.35	2.38	0.4
	NC9036			
CCFT060204HP	NC9031	6.35	2.38	0.4
CCFW060204	NC2032	6.35	2.38	0.4
CCMW060204	DM	6.35	2.38	0.4
CCMW09T304	DM	9.52	3.97	0.4
CCGT09T304HP	NC10	9.52	3.97	0.4
	K10			

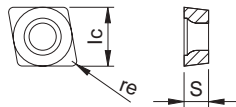

▶ 刀桿

訂購編號	Part No.	ØD	Ød	L1	L	刀片 / 螺絲	調整螺絲
99021-16	BC16-FB16	15.9~16.1	16	66	114	CC...060204 / 鎖刀片螺絲: NS-25060 0.9Nm 扳手:NK-T7, ⬡ 2.5mm	99021-A
99021-18	BC16-FB18	17.9~18.1	16	72	112		
99021-20	BC16-FB20	19.9~20.1	16	80	130		
99021-22	BC20-FB22	21.9~22.1	20	88	138		
99021-25	BC25-FB25	24.9~25.1	25	100	156		
99021-27	BC25-FB27	26.9~27.1	25	108	164	CC...09T30... / 鎖刀片螺絲: NS-35080 2.5Nm 扳手:NK-T15, ⬡ 4mm	99021-D
99021-28	BC25-FB28	27.9~28.1	25	112	168		
99021-30	BC25-FB30	29.9~30.1	25	120	176		
99021-32	BC25-FB32	31.9~32.1	25	128	184		
99021-35	BC32-FB35	34.9~35.1	32	140	200		
99021-37	BC32-FB37	36.9~37.1	32	140	200		
99021-40	BC32-FB40	39.9~40.1	32	140	200		
99021-42	BC32-FB42	41.9~42.1	32	140	200		
99021-45	BC32-FB45	44.9~45.1	32	140	200		
99021-47	BC32-FB47	46.9~47.1	32	140	200		
99021-50	BC32-FB50	49.9~50.1	32	140	200		

▶ 切削資料

	工件材質	加工狀況	刀片材種	線速 Vc (m/min)	二刃進給 (每轉)
P	碳鋼	一般切削 (瓷金) (需五彩亮面)	NC60	150 (120~180)	0.07 (0.05~0.10)
		斷屑切削	NC2033 / NC10	120 (100~140)	0.05 (0.04~0.08)
	合金鋼	一般切削 (瓷金)	NC60	120 (100~140)	0.07 (0.05~0.10)
		斷屑切削	NC2033 / NC10	100 (80~120)	0.05 (0.04~0.08)
M	不鏽鋼	一般切削	NC2033 / NC10	80 (70~100)	0.07 (0.05~0.10)
K	鑄鐵	耐磨鍍層	NC10 / NC2032	100 (80~120)	0.07 (0.05~0.10)
N	鋁合金	一般切削 (DLC)	NC9036	200 (150~300)	0.07 (0.05~0.10)
		一般切削 (無鍍層)	K10		
		一般切削 (鑽石)	DM	1000 (500~2000)	0.07 (0.05~0.10)

刀具轉速 $S = Vc \times 1000 \div 3.14 \div \text{ØD}$ (刀具直徑)

機台進給 $F = \text{轉速} \times X$ 每轉進給 fz

8

高速搪刀

鎖固型刀頭

- 可調整尺寸
調整範圍0.01mm

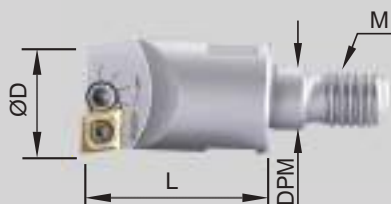

訂購編號	Part No.	ØD	L	M	延長桿	刀片 / 螺絲	調整螺絲
99043-14	M6-FB14	13.9~14.1	25	M6xP1.0	99801-12	CC...060204 / 鎖刀片螺絲: NS-25045 0.9Nm 扳手: NK-T7	99021-A
99043-15	M6-FB15	14.9~15.1	25	M6xP1.0	99801-12		
99043-16	M8-FB16	15.9~16.1	25	M8xP1.25	99801-14	CC...060204 / 鎖刀片螺絲: NS-25060 0.9Nm 扳手: NK-T7	99021-A
99043-17	M8-FB17	16.9~17.1	25	M8xP1.25	99801-14		
99043-18	M8-FB18	17.9~18.1	25	M8xP1.25	99801-16		
99043-19	M8-FB19	18.9~19.1	30	M8xP1.25	99801-16		
99043-20	M10-FB20	19.9~20.1	30	M10xP1.5	99801-18		
99043-21	M10-FB21	20.9~21.1	30	M10xP1.5	99801-18		
99043-22	M10-FB22	21.9~22.1	30	M10xP1.5	99801-20		
99043-23	M10-FB23	22.9~23.1	30	M10xP1.5	99801-20		
99043-24	M10-FB24	23.9~24.1	30	M10xP1.5	99801-20		
99043-25	M10-FB25	24.9~25.1	30	M10xP1.5	99801-20		

鋼柄

- T是最大可加工深度
- 中心出水型

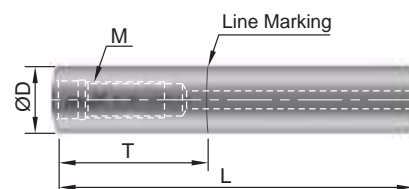

訂購編號	Part No.	ØD	T	L	M	組裝扭力
99801-10S	BC10-075M05S	10	25	75	M5xP0.8	6.5Nm
99801-12S	BC12-075M06S	12	25	75	M6xP1.0	11.0Nm
99801-14S	BC14-090M08S	14	30	90	M8xP1.25	25.0Nm
99801-16S	BC16-090M08S	16	35	90	M8xP1.25	25.0Nm
99801-18S	BC18-100M10S	18	40	100	M10xP1.5	50.0Nm
99801-20S	BC20-100M10S	20	40	100	M10xP1.5	50.0Nm
99801-25S	BC25-120M12S	25	50	120	M12xP1.75	60.0Nm
99801-32S	BC32-150M16S	32	65	150	M16xP2.0	-

鎢鋼接桿

- T是最大可加工深度
- 中心出水型

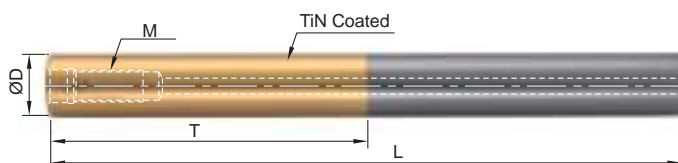

訂購編號	Part No.	ØD	T	L	M	組裝扭力
99801-10W	BC10-100M05W	10	50	100	M5xP0.8	6.5Nm
99801-12W	BC12-100M06W	12	60	100	M6xP1.0	11.0Nm
99801-14W	BC14-120M08W	14	70	120	M8xP1.25	25.0Nm
99801-16W	BC16-150M08W	16	80	150	M8xP1.25	25.0Nm
99801-18W	BC18-150M10W	18	90	150	M10xP1.5	50.0Nm
99801-20W	BC20-200M10W	20	100	200	M10xP1.5	50.0Nm
99801-25W	BC25-200M12W	25	125	200	M12xP1.75	60.0Nm

微調搪孔頭

容易調整

- 高精度容易調整 $0.02\text{mm}/\text{div}$ ，游標微調可至 $2\mu\text{m}$

廣泛運用

- 微調搪孔頭，可設計裝置在不同刀具
- 雙階孔安裝容易
- 可與大眾品牌規格互換

結構設計

- 使用彈力結構，沒有背隙
- 使用卡式刀座，尺寸可以更大範圍



微調搪孔頭

▶ 加工角度90°

- 使用刀片：CCMT, CCMW, CCGH, CCGT, CCGX, TCMT, TCMW, TCGT, TCGX
- 最大範圍 · 凹槽間隙不可大於扳手尾端寬度

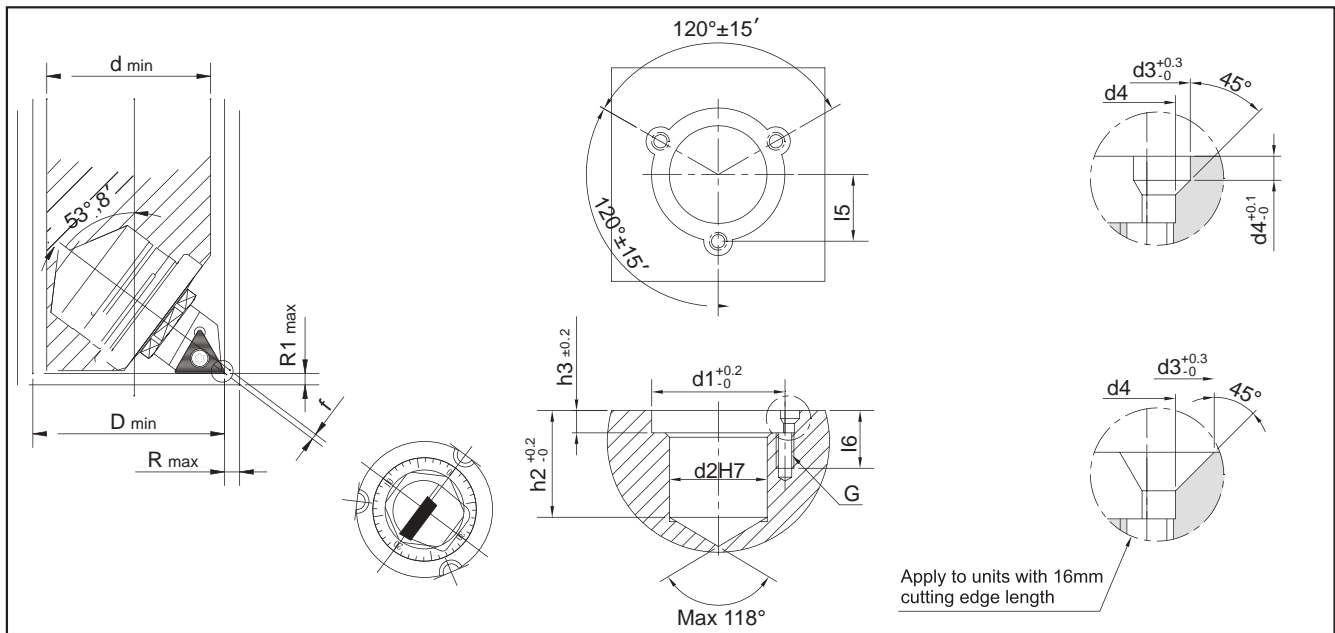

訂購編號	刀片 半徑	尺寸 / mm							安裝尺寸 / mm								
		dmin	Dmin	Rmin	R1max	f	h2	h3	h4	d1	d2	d3	d4	G	l6	l5	
3106	06	0.2	25.7	2	1.5	0.40	11.5	2.8	1.6	19	16	4.6	3.2	M3	10	9.65 ±0.02	
	0.4	25.4	0.40														
	0.8	24.8	0.45														
3209	09	0.2	33.4	2.8	2.1	0.95	15.5	4	1.6	25	20	4.6	3.2	M3	10	12.5 ±0.02	
		0.4	33.1														1.0
		0.8	32.5														1.1
3311	11	0.2	42.9	4.8	3.6	1.15	24	5	1.8	30	22	6.5	4.3	M4	15	15.4 ±0.02	
		0.4	42.6														1.2
		0.8	42.0														1.3
3416	16	0.2	60.6	8	6	1.3	33	6.3	-	46	32	11.9	5.4	M5	20	23 ±0.02	
		0.4	60.0														1.4
		1.2	59.4														1.5

▶ 設定與夾持零件

Item	刀片 半徑	扳手	安裝 螺絲	刀片 螺絲	安裝 螺絲扳手	刀片 螺絲扳手	安裝 螺絲扳手
3106	06	3106-SP	NS-30072	NS-25060	NK-T9	NK-T7	-
3209	09	3209-SP	NS-30072	191.958	NK-T9	NK-T7	-
3311	11	3311-SP	CS4011	NS-25060	NK-T15	NK-T7	-
3416	16	3416-SP	3416H	NS-35080	-	NK-T15	3146-J

8

高速
搪刀



加一個鎖固螺絲，可以增加尺寸調整精度

► 加強型設計

- 在本體側方向增加一個銅頭固定螺絲，可以避免在加工底面時，產生振動
- 使用加強結構後，搪孔更精準
- 可以加長刀片壽命

► 搪刀頭固定螺絲位置

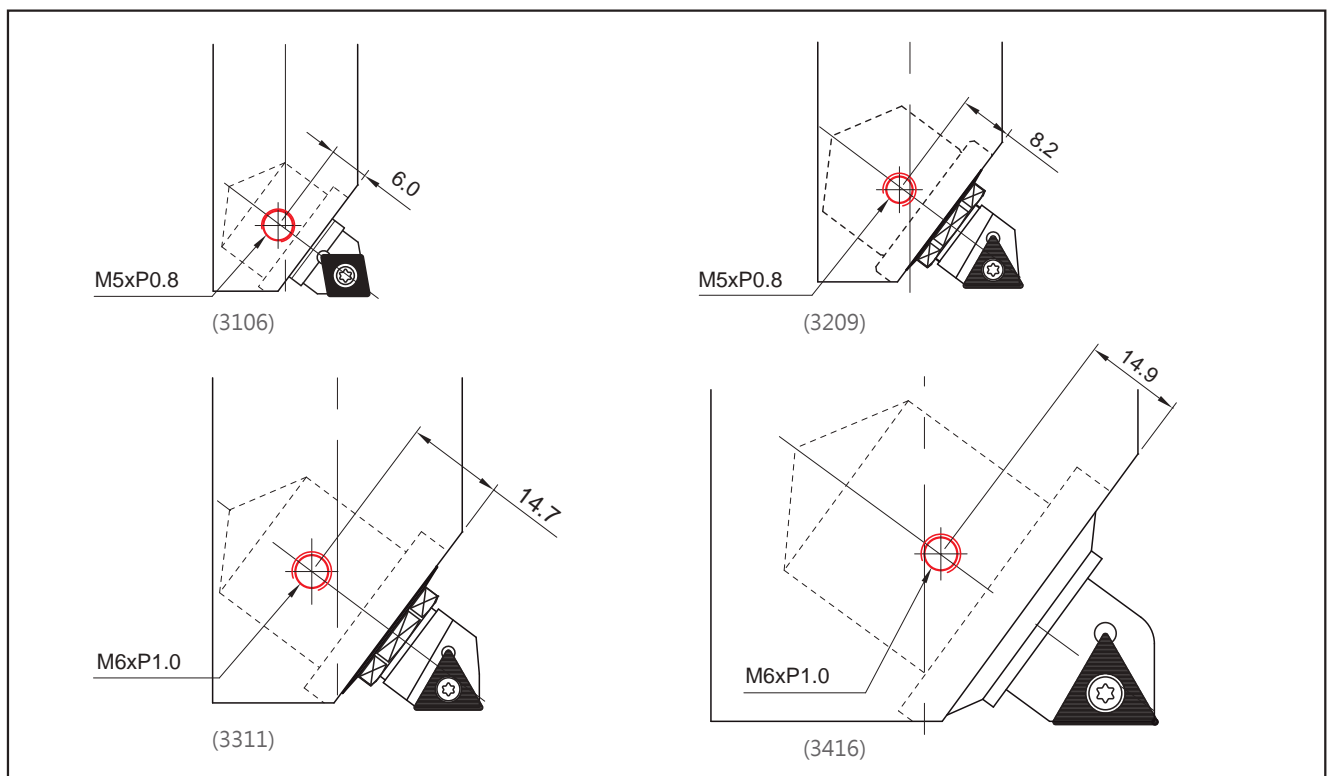

8

高速搪刀

訂購編號	MBU Type	Illustration		尺寸	
					l
NSC-50085	3106		06		8.5
NSC-50085	3209	09			8.5
NSC-60115	3311	11			11.5
NSC-60115	3416	16			11.5

附微調刻劃卡式刀座

解決問題特徵：

- 卡式刀座微調困難。
- 微調精搪頭，單價高。
- 孔段差小於 20mm，多層階級孔徑加工。
- 使用微調搪頭，刀桿強度差者。

使用要點：

1. 先將微調螺絲調到下限。
2. 再調整卡式刀座螺絲至所需尺寸。
3. 刀片損耗之尺寸補正僅需調整微調螺絲。
4. 微調螺絲使用方法參照直接式微調搪刀。

STFCR 10CA-11
STFPR 10CA-11
CTFPR 10CA-11

尺寸相容，相互性強

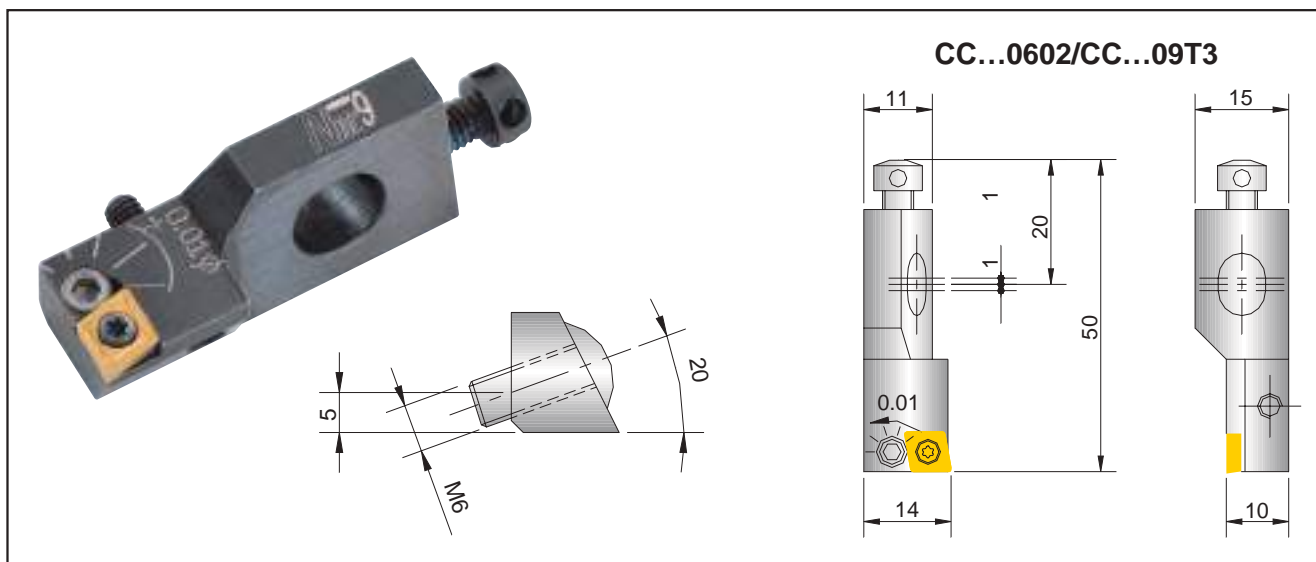

訂購編號	Part No.	刀片	取代卡座
99201-001	SCFCR 10CA-06MA	CC...0602	10CA
99201-004	SCFCR 08CA-06MA	CC...0602	08CA
99201-005	SCFCR 12CA-09MA	CC...09T3	12CA

Type			
刀片尺寸	CCMT0602	TCMT0902	TCMT1102
90°	SCFCR 08CA - 06 99211 - 90	STFCR 08CA - 09 99221 - 90	STFCR 10CA - 11 99231 - 90
75°	SCKCR 08CA - 06 99211 - 75	STKCR 08CA - 09 99221 - 75	STKCR 10CA - 11 99231 - 75
60°	SCWCR 08CA - 06 99211 - 60	STWCR 08CA - 09 99221 - 60	STWCR 10CA - 11 99231 - 60
45°	SCSCR 08CA - 06 99211 - 45	STSCR 08CA - 09 99221 - 45	STSCR 10CA - 11 99231 - 45
30°	SCTCR 08CA - 06 99211 - 30	STTCR 08CA - 09 99221 - 30	STTCR 10CA - 11 99231 - 30
15°	SCRCR 08CA - 06 99211 - 15	STRCR 08CA - 09 99221 - 15	STRCR 10CA - 11 99231 - 15
0°	SCGCR 08CA - 06 99211 - 00	STGCR 08CA - 09 99221 - 00	STGCR 10CA - 11 99231 - 00



高速搪刀

捨棄式倒拉沉頭刀

- 減少二次加工，增加微調機構，可加工精確培林孔。
- 不用正反轉，減少損壞機率。
- 特殊設計本體剛性最佳。

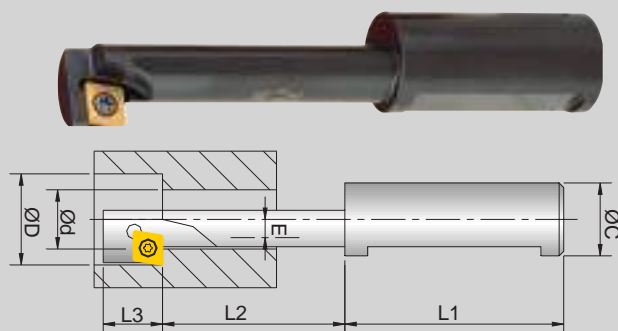

▶ 刀片

訂購編號			尺寸		
			lc	S	re
CCMT060204	NC40		6.35	2.38	0.4
	NC10				
CCFT060204	NC2033				
	NC9036				
CCFW060204	NC2032		6.35	2.38	0.4
CCMT09T308	NC40			9.52	3.97
	NC10				
CCGT09T304HP (鋁合金)	NC10	9.52		3.97	0.4
	K10				

▶ 刀桿

訂購編號	Part No.	ØD	Ød	ØC	L1	L2	L3	E	刀片 / 螺絲 / 扳手
99611-M08	M08-1308	13.5	9	20	50	50	13	2.5	TCMT06T104-NC40 / NS-20045 0.6Nm / NK-T6
99611-M10	M10-1810	18	10.5	16	48	35	13	4.0	CC...060204 / NS-25045 0.9Nm / NK-T7
99611-M12	M12-2013	20	13	16	48	40	13	4.0	
99611-M14	M14-2315	23	15	20	50	50	13	4.5	
99611-M16	M16-2617	26	17	20	50	50	13	5.0	CC...09T30.. / NS-35080 2.5Nm / NK-T15
99611-M20	M20-3321	33	21	25	56	70	13	6.5	
99611-M24	M24-4025	40	25	25	56	80	13	8.0	

▶ 切削資料

	工件材質	加工狀況	刀片材種	線速 Vc (m/min)	每刃進給 fz(mm/tooth)	
					CCMT060204	CCMT09T308
P	碳鋼(合金鋼)	斷屑切削	NC40	50(40~60)	0.02(0.01~0.03)	0.03(0.02~0.04)
			NC2033			
M	不鏽鋼	斷屑切削	NC40	50(40~60)	0.02(0.01~0.03)	0.03(0.02~0.04)
			NC2033			
K	鑄鐵	一般切削	NC2032	60(40~80)	0.03(0.01~0.05)	0.04(0.03~0.06)
			NC10			
N	鋁合金	一般切削	NC9036	80(60~100)	0.04(0.02~0.06)	0.06(0.04~0.08)
			K10			

刀具轉速 S = $V_c \times 1000 \div 3.14 \div \phi D$ (刀具直徑)

機台進給 F = 轉速 S X 每轉進給 fz

8

高速搪刀

捨棄式倒拉倒角刀

- 不用正反轉，減少損壞機率。
- 特殊設計本體剛性最佳。

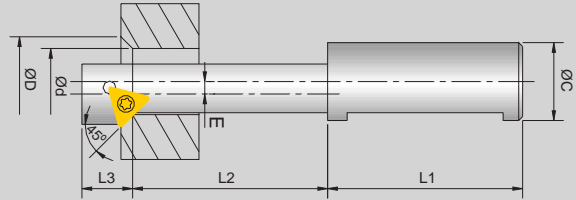

▶ 刀片

訂購編號	刀片	尺寸		
		L	S	re
TCMT110204 NC40		11	2.38	0.4
NC10				
TCGT110204 K10		11	2.38	0.4

▶ 刀桿

訂購編號	Part No.	ØD	Ød	ØC	L1	L2	L3	E	刀片 / 螺絲 / 扳手
99612-20	BC-2014	20	14	16	48	40	13	3.5	TCMT110204 / NS-25060 0.9Nm / NK-T7
99612-23	BC-2317	23	17	20	50	50	13	3.5	
99612-27	BC-2721	27	21	25	56	70	13	3.5	
99612-31	BC-3124	31	24	25	56	80	13	4.0	

▶ 切削資料

	工件材質	加工狀況	刀片材種	線速 Vc (m/min)	每刃進給 fz(mm/tooth)
P	鋼	一般切削	NC40	80(60~120)	0.03(0.02~0.07)
K	鑄鐵	一般切削	NC10	80(60~120)	0.03(0.02~0.07)
N	鋁合金	一般切削	K10	150(100~120)	0.05(0.04~0.10)

刀具轉速 $S = Vc \times 1000 \div 3.14 \div \phi D$ (刀具直徑)

機台進給 $F = \text{轉速} S \times \text{每轉進給} fz$

▶ 倒拉刀加工步驟：

1. 主軸定位
2. 偏心位移 (E 值)
3. Z 軸深入
4. 恢復中心 (E 值)
5. 正轉向上加工
6. 主軸定位
7. 偏心位移 (E 值)
8. 向上脫離，完成加工

8

高速
搪刀

捨棄式沉頭刀

- 捨棄式加工快速
- 成本低廉

N9MT11T308 在沉頭刀使用時，內孔加工可用 4 次，倒角可使用 4 次，共使用 8 次，而且刀片强度高，本體耐用不易損壞。

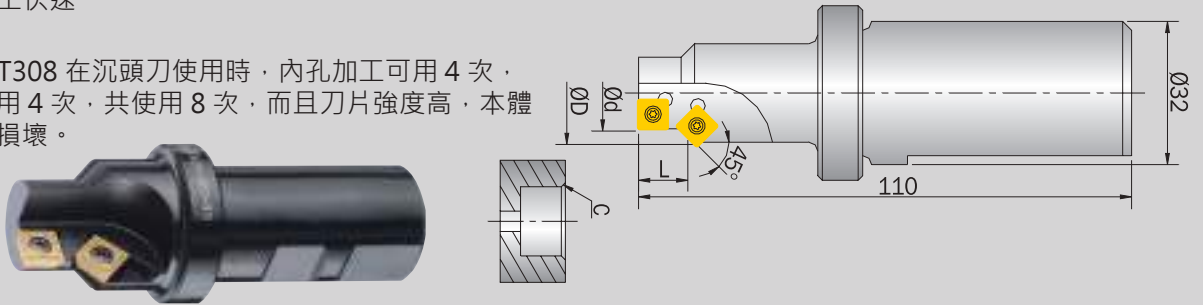

▶ 刀片

訂購編號		尺寸		
		L	S	re
N9MT06T203H-NC2033		6.35	2.78	0.3
N9MT11T308LANC40		11.11	3.97	0.8

▶ 刀桿

訂購編號	Part No.	ØD	Ød	L	C	刀片 / 螺絲 / 扳手
99614-06C	M06-06C-N9	19	11	7	1C	N9MT06T203H / NS-25045 0.9Nm / NK-T7
99614-08C	M08-08C-N9	20	14	9		
99614-10C	M10-10C-N9	24	18	11		
99614-12C	M12-12C-N9	26	20	13.5	2C	N9MT11T308 / NS-35080 2.5Nm / NK-T15
99614-14C	M14-14C-N9	31	23	15		
99614-16C	M16-16C-N9	34	26	18		
99614-20C	M20-20C-N9	40	32	22		
99614-24C	M24-24C-N9	47	39	26		

▶ 切削資料

工件材質	加工狀況	刀片材種	線速 Vc (m/min)	每刃進給 fz(mm/tooth)	
				N9MT06T203H	N9MT11T308LA
軟鐵SS41	一般加工	NC40	120(100~150)	0.05(0.03~0.07)	0.06(0.05~0.07)
		NC2033			
碳鋼	一般加工	NC40	80(60~100)	0.08(0.06~0.09)	0.08(0.06~0.10)
		NC2033			

刀具轉速 $S = Vc \times 1000 \div 3.14 \div \phi D$ (刀具直徑)

機台進給 $F = \text{轉速 } S \times \text{每轉進給 } fz$

8

高速搪刀

沉頭鑽

- 把傳統的鑽孔及沉頭加工，結合成一把刀，一次加工完成
- 大幅提高螺絲沉頭孔的加工效率

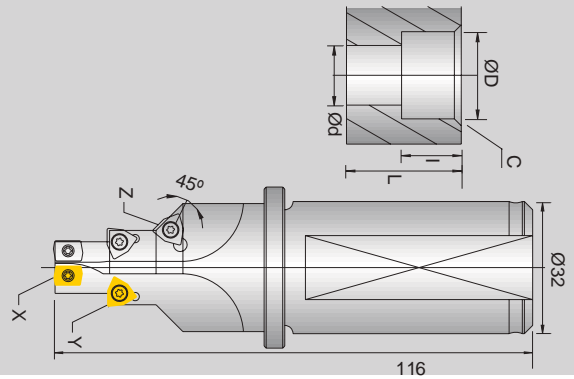

▶ 刀片

訂購編號		尺寸			
		L	W	S	re
N9GL020204-NC40		7.12	4.90	2.20	0.4
N9GL030204-NC40		8.71	6.00	2.50	0.4
N9GX040304-NC40		4.00	-	3.0	0.4

▶ 刀桿

訂購編號	Part No.	ØD	ød	l	L	C	刀片 / 螺絲 / 扳手		
							X	Y	Z
99614-M12DC-L25	M12DC-L25	19	13	13	25	1	N9GL020204 / NS-20045 / NK-T6	N9GX040304 x 3 / NS-25060 / NK-T7	
99614-M14DC-L25	M14DC-L25	22	15	15	25	1.5			
99614-M14DC-L30	M14DC-L30	22	15	15	30	1.5			
99614-M16DC-L30	M16DC-L30	25	17	17	30	1.5	N9GL030204 / NS-22052 / NK-T7	N9GX040304 x 3 / NS-25060 / NK-T7	
99614-M16DC-L35	M16DC-L35	25	17	17	35	1.5			

▶ 切削資料

工件材質	加工狀況	刀片材種	線速 Vc (m/min)	每刃進給 fz(mm/tooth)	
				N9GL020204	N9GL030204
P 碳鋼	一般加工	NC40	100(80~120)	0.05(0.04~0.06)	0.08(0.06~0.10)

★軟鐵 SS41 切削不易斷屑，不建議使用

刀具轉速 $S = Vc \times 1000 \div 3.14 \div \phi D$ (刀具直徑)

機台進給 $F = \text{轉速} \times S \times \text{每轉進給} fz$

8

高速
搪刀



ER錐柄 捨棄式刀具

ERgo 是耐久公司(Nine-9) 新開發ER捨棄式刀具，可迅速使用在瑞士型自動車床或CNC車床的動力刀塔上。



- ▶ ER夾持系統，柄部為ER斜度之刀具。
切削組件包含ERgo螺母、高強度ERgo拉鞘、ERgo 本體刀桿。



Concept >>>

▶ 增加刀具強度和刀具壽命

- 一體式設計刀桿，消除組裝公差。
- 預校動平衡，有利高速加工。增加刀具壽命3 ~ 5倍。

ERgo 一體式設計刀桿



- 提高刀具同心度
- 增加剛性

刀具 + 彈性筒夾

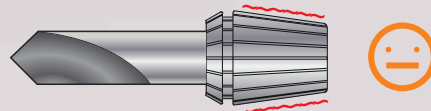

- 旋緊ER 螺帽時，請注意旋緊不均勻的情況。
- 碎屑、生鏽或夾頭變形。



Features

► 使用簡單、快速

- ERgo工具提供組裝好的套件，更換工具只需要幾秒鐘。
- 因為ER錐度，在更換相同長度的刀具時，公差 $\pm 0.1\text{mm}$ 。



優異的重現性

- 捨棄式刀片，節省換刀時間
- 更換刀片或切削刃後，鑽孔深度固定不變。

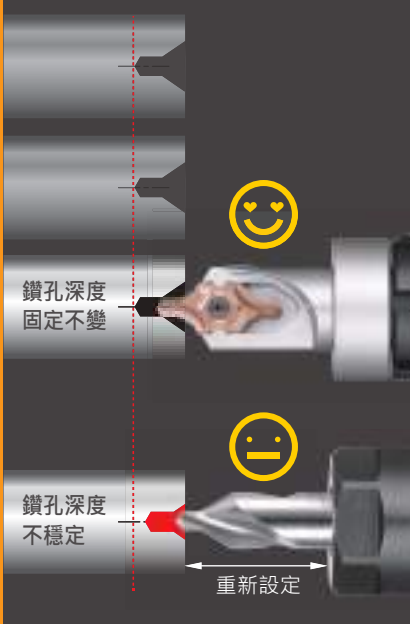

不受ER16的刀具直徑限制

- ERgo ER16銑刀直徑範圍從10至32mm。
- 更高的效率以及加工更大零件的可能性

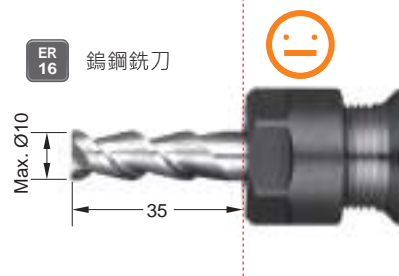

“ ERgo 系統包含：
刀霸銑刀，雕刻刀，
去毛邊刀，中心鑽以及
搪刀。 ”

雕刻刀、 0.1mm定位鑽、去毛邊刀

G4.0 20,000 r.p.m.



X060

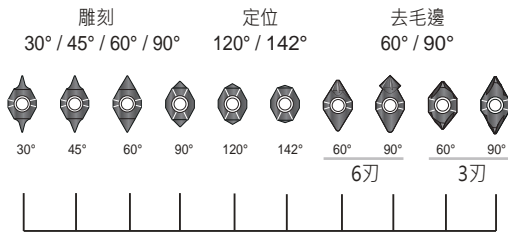

99816-X060

OAL= 33.5mm

ER11 / ER16 / ER20 / ER25 Ø10mm~ Ø32 mm 刀霸銑刀

中心出水 / G6.3 10000 r.p.m



A9GT0602

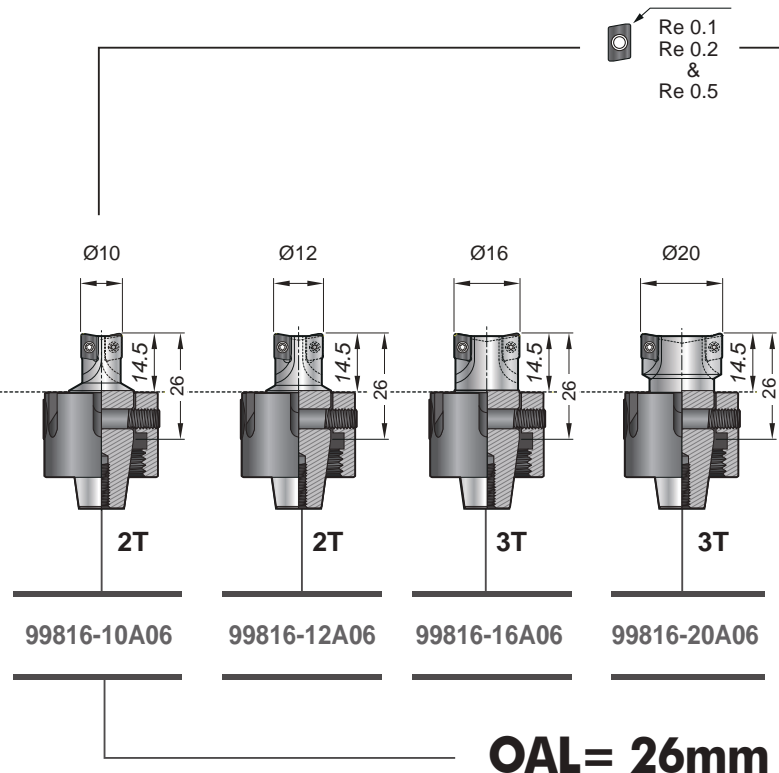

OAL= 26mm

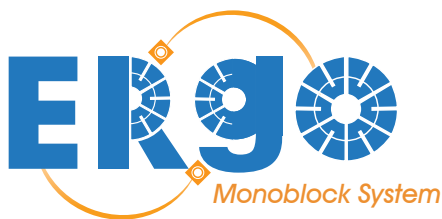

99811 / 99816
99820 / 99825

ERgo系統可使用於車銑中心機的動力刀座和瑞士型自動車床，例如：Star · Citizen · Tsugami · Doosan · Tornos · INDEX · EMAG ...等。以及任何切削中心機。

ERgo ER16 M19 螺母

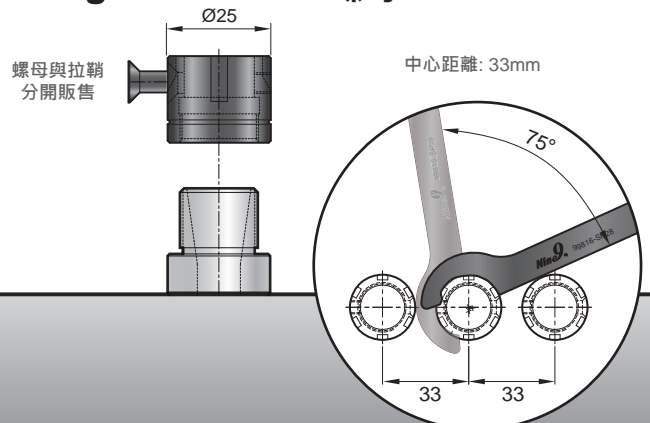

P.
9-176

P.
9-182

P.
9-178

中心鑽

中心出水
G6.3 10000 r.p.m

搪刀

ER16
ER20

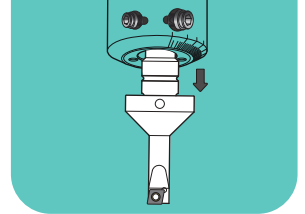
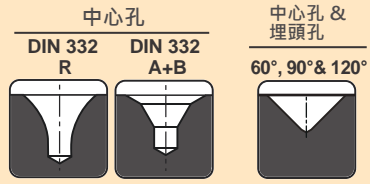

I9MT1003

CC...

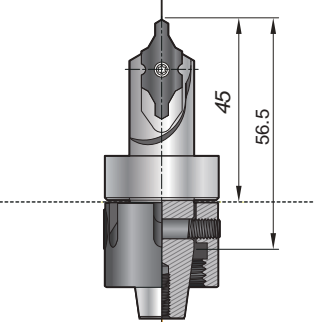
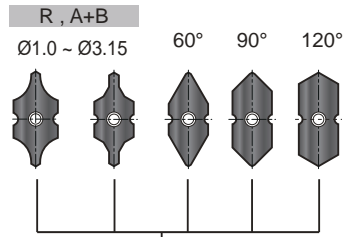
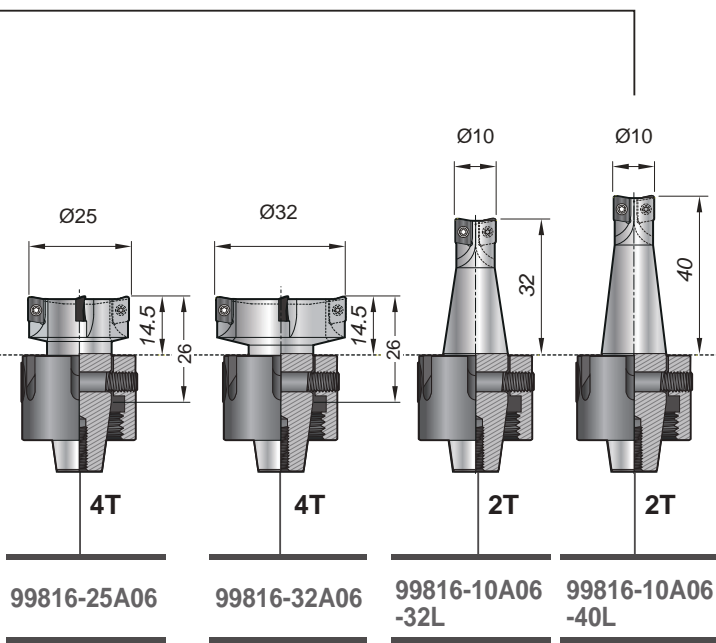

99816-IC10BH

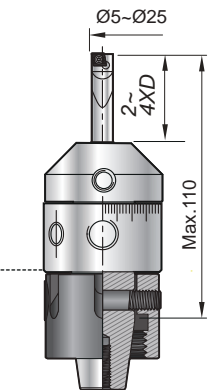

99816-B02
99820-B01

OAL= 56.5mm

P.
9-185

刀長設定器

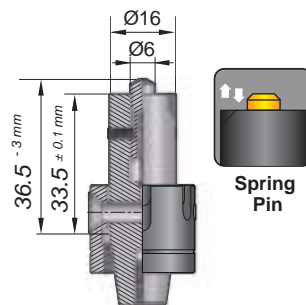

99816-TP

ERgo ER16 M22 螺母

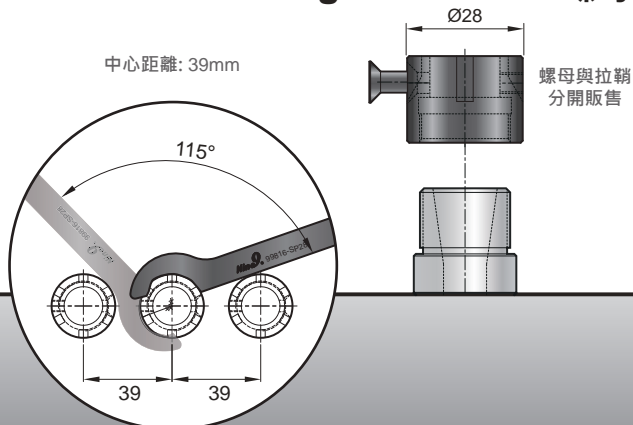

組裝零件

刀片



刀桿



螺母及拉鞘



套組

(詳見P. 9-187)



6

ERgo

ER16 X060 雕刻刀

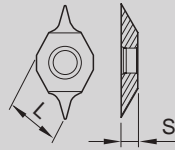

材質	P	M	N
NC2032	●	●	
XP9001			●

▶ 定點鑽刀片 >>

● 圓鼻尖雕刻刀片

角度	訂購編號	鍍層	材質	L	S	Re	Wmin.	Wmax.	Tmax.
30°	X060A30W020R	NC2032	TiAlN	6	2.05	0.04	0.20	0.74	0.6
		XP9001	Uncoated						
45°	X060A45W020R	NC2032	TiAlN	6	2.05	0.04	0.20	1.03	0.8
		XP9001	Uncoated						
60°	X060A60W020R	NC2032	TiAlN	6	2.05	0.04	0.20	1.36	1.0
		XP9001	Uncoated						
90°	X060A90W010R	NC2032	TiAlN	6	2.05	0.02	0.10	1.1	0.5
		XP9001	Uncoated						
90°	X060A90W020R	NC2032	TiAlN	6	2.05	0.04	0.20	2.2	1.0
		XP9001	Uncoated						

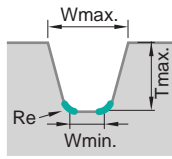

● 圓球尖雕刻刀片

角度	Part No.	鍍層	材質	L	S	Re	R max. Depth	Wmax.	Tmax.
30°	X060A30R020	NC2032	TiAlN	6	2.05	0.2	0.15	0.84	0.6
		XP9001	Uncoated						
45°	X060A45R020	NC2032	TiAlN	6	2.05	0.2	0.12	1.1	0.8
		XP9001	Uncoated						
60°	X060A60R020	NC2032	TiAlN	6	2.05	0.2	0.10	1.39	1.0
		XP9001	Uncoated						

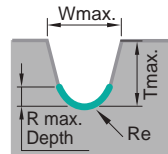

▶ 本體刀桿與零配件 >>

Part No.	本體刀桿	L	螺絲	扳手
99816-X060		22	 NS-22044 0.9Nm	 NK-T7

ERgo 螺母套組		ERgo 螺母			高強度 ERgo 拉鞘			L 型扳手	ERgo 螺母扳手
	* 包含螺母、拉鞘和L型扳手。		Ød	牙距	扭力		L	扭力	
ER 錐柄	訂購編號	訂購編號	Ød	牙距	扭力	訂購編號	L	扭力	訂購編號
ER16	99816-M19S	99816-M19	25	M19xP1.0	30 Nm	NS-50025	25	5 Nm	NK-LW3
	99816-M22S	99816-M22	28	M22xP1.5	30 Nm	NS-50028	28	5 Nm	

9

ERgo

ER16 X060 定點鑽 / 去毛邊刀

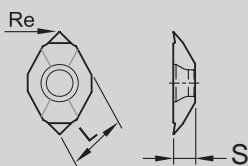

材質	P	M	N
NC2032	●	●	
XP9001			●

▶ 定點鑽刀片 >>

● 圓鼻尖雕刻刀片

角度	訂購編號	鍍層	材質	L	S	Re	Wmin.	Wmax.	Tmax.
90°	X060A90W010R	NC2032	TiAlN	6	2.05	0.02	0.10	1.10	0.5
		XP9001	Uncoated						
120°	X060A120W010R	NC2032	TiAlN	6	2.05	0.02	0.10	2.53	0.7
142°	X060A142W010R	NC2032	TiAlN	6	2.05	0.02	0.10	2.42	0.4

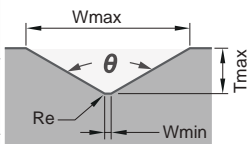

▶ 去毛邊刀片 >>

刃數	角度	訂購編號	鍍層	材質	尺寸	Tmin.	Tmax.		
								L	S
3	60°	X060A60T3-XP9001	Uncoated	K20F		6	2.8	0.1	0.9
		X060A60T3-NC2032	TiAlN						
	90°	X060A90T3-XP9001	Uncoated						
		X060A90T3-NC2032	TiAlN						
6	60°	X060A60T6-NC2032	TiAlN	K20F		6	2.0	0.1	1.8
	90°	X060A90T6-NC2032						0.5	1.5

▶ 本體刀桿與零配件 >>

Part No.	本體刀桿	L	螺絲	扳手
99816-X060		22	NS-22044 0.9Nm	NK-T7

ERgo 螺母套組		ERgo 螺母			高強度 ERgo 拉鞘			L 型扳手	ERgo 螺母扳手	
	* 包含螺母、拉鞘和L型扳手。		Ød	牙距	扭力					
ER 錐柄	訂購編號	訂購編號	Ød	牙距	扭力	訂購編號	L	扭力	訂購編號	訂購編號
ER16	99816-M19S	99816-M19	25	M19xP1.0	30 Nm	NS-50025	25	5 Nm	NK-LW3	99816-SP28
	99816-M22S	99816-M22	28	M22xP1.5	30 Nm	NS-50028	28	5 Nm		

ER11 / ER16 / ER20 / ER25 刀霸銑刀



H type



U type

▶ 刀片 >>

- U 系列刀片適用於長刀桿。

訂購編號	鍍層	材質	Re	Ap	L	W	S
A9GT060201H	NC2033	TiAlN	0.1	5	6.5	4	2.45
	NC9031	TiN					
A9GT060202H	NC2033	TiAlN	0.2	5	6.5	4	2.45
	NC9031	TiN					
A9GT060205H	NC2033	TiAlN	0.5	5	6.5	4	2.45
	NC9031	TiN					
A9GT060201U	NC2032	TiAlN	0.1	5	6.5	4	2.45
A9GT060202U	NC2032	TiAlN	0.2	5	6.5	4	2.45
A9GT060205U	NC2032	TiAlN	0.5	5	6.5	4	2.45

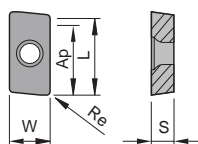

▶ 本體刀桿 >>

- 可根據要求訂製，請參考第 9-188 頁。

ER 錐柄	訂購編號	本體刀桿	ØD	L	刃數	α°	螺絲	扳手		
ER11	99811-10A06		10	14	2	5				
	99811-12A06		12		2	4				
ER16 (含中心出水)	99816-10A06		10	14.5	2	5				
	99816-12A06		12		2	4				
	99816-16A06		16		3	2				
	99816-20A06		20		3	2				
	99816-25A06		25		4	1.3				
	99816-32A06		32		4	1				
ER20	99820-12A06		12	26	2	4			NS-18037 0.6Nm	NK-T6
	99820-16A06		16		3	2				
	99820-20A06		20		3	2				
	99820-25A06		25		4	1.3				
ER25	99825-12A06		12	33	2	4				
	99825-16A06		16		3	2				
	99825-20A06		20		3	2				
	99825-25A06		25		4	1.3				

ER16 / ER20 刀霸銑刀 - 加長系列

▶ **本體刀桿與零配件** >> • 錐狀設計且加長的一體式設計刀桿，增強了刀具強度及消除了組裝公差。

ER 錐柄	訂購編號	本體刀桿	ØD	L1	刃數	α°	螺絲	扳手
ER16	99816-10A06-32L		10	32	2	5		
	99816-10A06-40L		10	40	2	5		
ER20	99820-10A06-40L		10	40	2	5		
	99820-12A06-40L		12	40	2	4		

ERgo 螺母套組		ERgo 螺母			高強度 ERgo 拉鞘			L 型扳手	ERgo 螺母扳手	
* 包含螺母、拉鞘和L型扳手。										
ER 錐柄	訂購編號	訂購編號	Ød	牙距	扭力	訂購編號	L	扭力	訂購編號	訂購編號
ER11	99811-M13S	99811-M13	19	M13xP0.75	12 Nm	NS-40019	19	3 Nm	NK-LW25	99811-SP20
ER16	99816-M19S	99816-M19	25	M19xP1.0	30 Nm	NS-50025	25	5 Nm	NK-LW3	99816-SP28
	99816-M22S	99816-M22	28	M22xP1.5	30 Nm	NS-50028	28	5 Nm		
ER20	99820-M24S	99820-M24	34	M24xP1.0	45 Nm	NS-60033	33	6 Nm	NK-LW4	99820-SP36
	99820-M25S	99820-M25	34	M25xP1.5	45 Nm	NS-60033	33	6 Nm		
ER25	99825-M32S	99825-M32	42	M32xP1.5	60 Nm	NS-80041	41	8 Nm	NK-LW5	99825-SP42

▶ 切削資料 >>

工件材質	刀片材質	Vc (m/min)	fz (mm/tooth)			
P 碳鋼 低合金鋼 C ≤ 0.3% 高合金鋼 C > 0.3%	NC2033, NC2032	80 ~ 150	0.03 ~ 0.07	1.5	3	1
	NC2033, NC2032	60 ~ 120	0.02 ~ 0.06	1.0	2.5	1
	NC2033, NC9031 (精加工)	60 ~ 120	0.01 ~ 0.05	0.5	2.0	1
M 不鏽鋼	NC2033, NC9031 (精加工)	60 ~ 120	0.01 ~ 0.05	0.5	2.0	1
N 鋁·鋁合金	NC2032, NC9031	200 ~ 500	0.02 ~ 0.07	2.0	4.0	2

▶ 性能 >>

• 表面粗糙度

Ø10 Ergo 刀霸銑刀	Ø10 捨棄式銑刀	Ø10 端銑刀
VB=0.04 mm 無崩裂 😊	VB=0.04 mm 部份崩裂 😞	VB=0.20 mm 大面積崩裂 😞

• 測量VB值 (刀具磨損) 和崩刃狀況

表面處理很好 😊	約 50% 的表面粗糙 😞	約 80% 的表面粗糙 😞

ER16 / ER20 可調式深孔搪刀

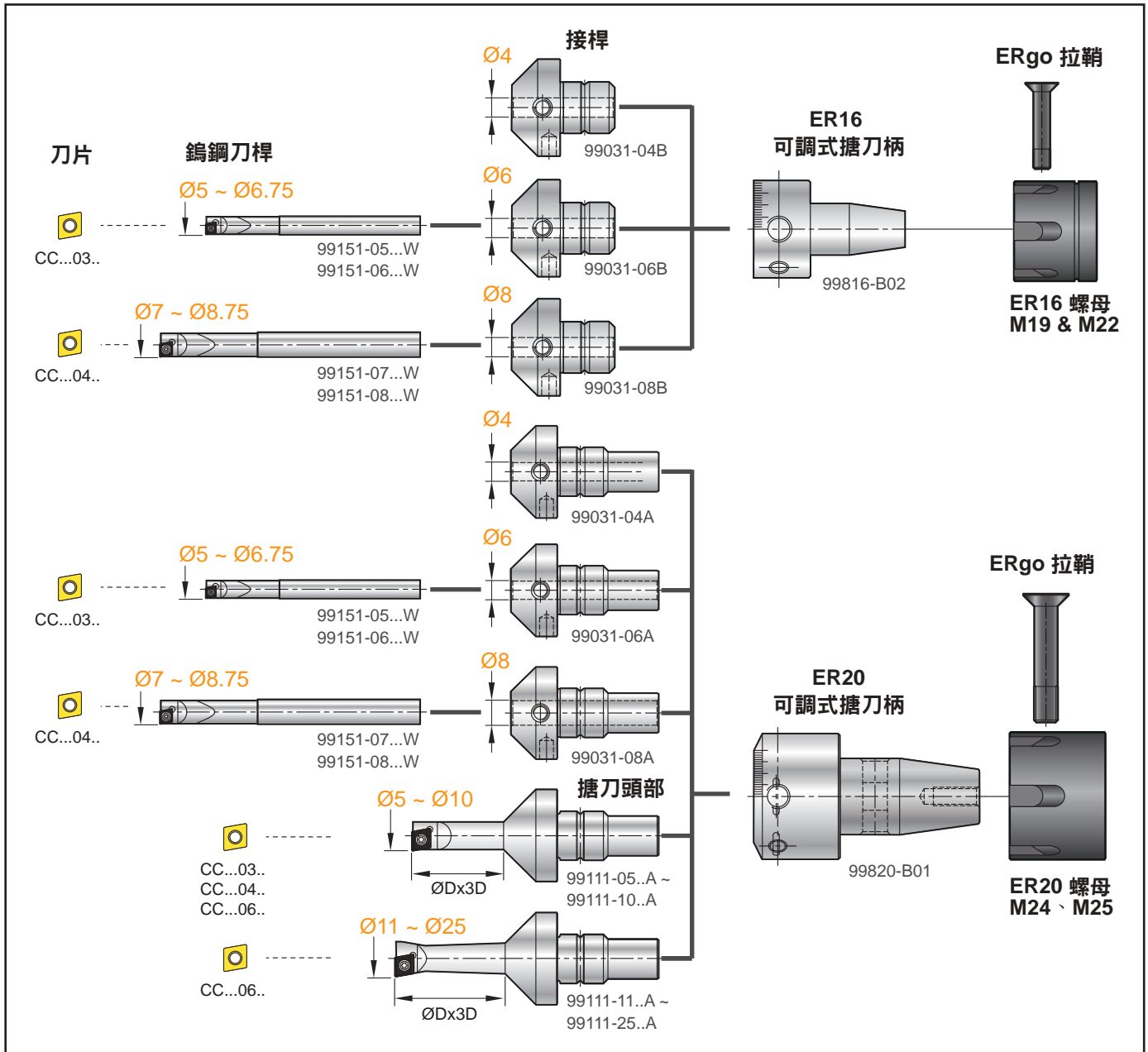

▶ 刀片 >>

材質	● 最好的 ◎合適的 ○可能的		
	P	M	N
NC30	●	●	
NC9036			●
NC2033	●	●	
NC9031			●
DM			●

訂購編號	鍍層	材質	尺寸		
			lc	S	Re
CCGT030102	NC30	TiAlN	3.5	1.4	0.2
	NC9036	DLC			
CCGT040102	NC30	TiAlN	4.3	1.8	0.2
	NC9036	DLC			
CCGW040102	DM	-	DM		
CCFT060204	NC2033	TiN	6.35	2.38	0.4
	NC9036	DLC			
CCFT060204HP	NC9031	TiN			
CCMW060204	DM	-	DM		

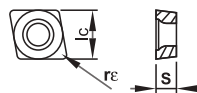

9

ERgo

ER16 / ER20 可調式深孔搪刀

▶ 本體刀桿與零配件 >>

ER 錐柄	訂購編號	Part No.	本體刀桿	ØD	L	適用接桿
ER16	99816-B02	N9ER16-B02		30	17.5	99031-04B 99031-06B 99031-08B
ER20	99820-B01	N9ER20-B01		41	28	99031-04A 99031-06A 99031-08A

ERgo 螺母套組		ERgo 螺母			高強度 ERgo 拉鞘			L 型扳手	ERgo 螺母扳手	
<p>* 包含螺母、拉鞘和L型扳手。</p>										
ER 錐柄	訂購編號	訂購編號	Ød	牙距	扭力	訂購編號	L	扭力	訂購編號	訂購編號
ER16	99816-M19S	99816-M19	25	M19xP1.0	30 Nm	NS-50025	25	5 Nm	NK-LW3	99816-SP28
	99816-M22S	99816-M22	28	M22xP1.5	30 Nm	NS-50028	28	5 Nm		
ER20	99820-M24S	99820-M24	34	M24xP1.0	45 Nm	NS-60033	33	6 Nm	NK-LW4	99820-SP36
	99820-M25S	99820-M25	34	M25xP1.5	45 Nm	NS-60033	33	6 Nm		

▶ 接桿 >>

ER 錐柄	訂購編號	Part No.	接桿	Ød	L
ER16	99031-04B	C16-ID04B		4	16.75
	99031-06B	C16-ID04B		6	
	99031-08B	C16-ID04B		8	
ER20	99031-04A	C16-ID04A		4	33
	99031-06A	C16-ID06A		6	
	99031-08A	C16-ID08A		8	

▶ 鎢鋼刀桿 >>

- Solid Carbide Shank
- Boring Depth : L1, 4xD

訂購編號	Part No.	ØD	Ød	L1	L	刀片/螺絲/扳手	圖示
99151-0500W	C06-0500-20L	4.87~5.12	6	20.00	70	刀片: CC..030102 螺絲: NS-16030 扳手: NK-T6	
99151-0525W	C06-0525-20L	5.12~5.37	6	20.00	70		
99151-0550W	C06-0550-22L	5.37~5.62	6	22.00	70		
99151-0575W	C06-0575-22L	5.62~5.87	6	22.00	70		
99151-0600W	C06-0600-24L	5.87~6.12	6	24.00	70		
99151-0625W	C06-0625-24L	6.12~6.37	6	24.00	70		
99151-0650W	C06-0650-26L	6.37~6.62	6	26.00	70		
99151-0675W	C06-0675-26L	6.62~6.87	6	26.00	70	刀片: CC..040102 螺絲: NS-20036 扳手: NK-T6	
99151-0700W	C08-0700-28L	6.87~7.12	8	28.00	85		
99151-0725W	C08-0725-28L	7.12~7.37	8	28.00	85		
99151-0750W	C08-0750-30L	7.37~7.62	8	30.00	85		
99151-0775W	C08-0775-30L	7.62~7.87	8	30.00	85		
99151-0800W	C08-0800-32L	7.87~8.12	8	32.00	85		
99151-0825W	C08-0825-32L	8.12~8.37	8	32.00	85		
99151-0850W	C08-0850-34L	8.37~8.62	8	34.00	85		
99151-0875W	C08-0875-34L	8.62~8.87	8	34.00	85		

ER20 搪刀頭部

▶ Ø5mm ~ Ø10mm
搪刀頭部

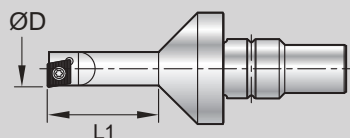

訂購編號	Part No.	ØD	L1	刀片	扳手 / 螺絲
99111-05A	C16-0500-15L	4.87-5.12	15	CC...030102	NK-T6 / NS-16030 0.4Nm
99111-0525A	C16-0525-15L	5.12-5.37	15		
99111-0550A	C16-0550-15L	5.37-5.62	15		
99111-0575A	C16-0575-15L	5.62-5.87	15		
99111-06A	C16-0600-18L	5.87-6.12	18		
99111-0625A	C16-0625-18L	6.12-6.37	18		
99111-0650A	C16-0650-18L	6.37-6.62	18		
99111-0675A	C16-0675-18L	6.62-6.87	18		
99111-07A	C16-0700-21L	6.87-7.12	21	CC...040102	NK-T6 / NS-20036 0.6Nm
99111-0725A	C16-0725-21L	7.12-7.37	21		
99111-0750A	C16-0750-21L	7.37-7.62	21		
99111-0775A	C16-0775-21L	7.62-7.87	21		
99111-08A	C16-0800-24L	7.87-8.12	24		
99111-0825A	C16-0825-24L	8.12-8.37	24		
99111-0850A	C16-0850-24L	8.37-8.62	24		
99111-0875A	C16-0875-24L	8.62-8.87	24		
99111-09A	C16-0900-27L	8.87-9.12	27	CC...060204	NK-T7 / NS-25045 0.9Nm
99111-0925A	C16-0925-27L	9.12-9.37	27		
99111-0950A	C16-0950-27L	9.37-9.62	27		
99111-0975A	C16-0975-27L	9.62-9.87	27		
99111-10A	C16-1000-30L	9.87-10.12	30		
99111-1025A	C16-1025-30L	10.12-10.37	30		
99111-1050A	C16-1050-30L	10.37-10.62	30		
99111-1075A	C16-1075-30L	10.62-10.87	30		

ER20 搪刀頭部

▶ $\varnothing 11\text{mm} \sim \varnothing 25\text{mm}$
搪刀頭部

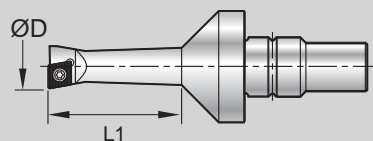

訂購編號	Part No.	ØD	L1	刀片 扳手 / 螺絲	訂購編號	Part No.	ØD	L1	刀片 扳手 / 螺絲
99111-11A	C16-1100-33L	10.87-11.12	33	CC...060204 NK-T7 / NS-25045 0.9Nm	99111-18A	C16-1800-50L	17.87-18.12	50	CC...060204 NK-T7 / NS-25060 0.9Nm
99111-1125A	C16-1125-33L	11.12-11.37	33		99111-1825A	C16-1825-50L	18.12-18.37	50	
99111-1150A	C16-1150-33L	11.37-11.62	33		99111-1850A	C16-1850-50L	18.37-18.62	50	
99111-1175A	C16-1175-33L	11.62-11.87	33		99111-1875A	C16-1875-50L	18.62-18.87	50	
99111-12A	C16-1200-36L	11.87-12.12	36		99111-19A	C16-1900-50L	18.87-19.12	50	
99111-1225A	C16-1225-36L	12.12-12.37	36		99111-1925A	C16-1925-50L	19.12-19.37	50	
99111-1250A	C16-1250-36L	12.37-12.62	36		99111-1950A	C16-1950-50L	19.37-19.62	50	
99111-1275A	C16-1275-36L	12.62-12.87	36		99111-1975A	C16-1975-50L	19.62-19.87	50	
99111-13A	C16-1300-39L	12.87-13.12	39		99111-20A	C16-2000-50L	19.87-20.12	50	
99111-1325A	C16-1325-39L	13.12-13.37	39		99111-2025A	C16-2025-50L	20.12-20.37	50	
99111-1350A	C16-1350-39L	13.37-13.62	39		99111-2050A	C16-2050-50L	20.37-20.62	50	
99111-1375A	C16-1375-39L	13.62-13.87	39		99111-2075A	C16-2075-50L	20.62-20.87	50	
99111-14A	C16-1400-42L	13.87-14.12	42		99111-21A	C16-2100-50L	20.87-21.12	50	
99111-1425A	C16-1425-42L	14.12-14.37	42		99111-2125A	C16-2125-50L	21.12-21.37	50	
99111-1450A	C16-1450-42L	14.37-14.62	42		99111-2150A	C16-2150-50L	21.37-21.62	50	
99111-1475A	C16-1475-42L	14.62-14.87	42		99111-2175A	C16-2175-50L	21.62-21.87	50	
99111-15A	C16-1500-45L	14.87-15.12	45		99111-22A	C16-2200-50L	21.87-22.12	50	
99111-1525A	C16-1525-45L	15.12-15.37	45		99111-2225A	C16-2225-50L	22.12-22.37	50	
99111-1550A	C16-1550-45L	15.37-15.62	45		99111-2250A	C16-2250-50L	22.37-22.62	50	
99111-1575A	C16-1575-45L	15.62-15.87	45		99111-2275A	C16-2275-50L	22.62-22.87	50	
99111-16A	C16-1600-48L	15.87-16.12	48	99111-23A	C16-2300-50L	22.87-23.12	50		
99111-1625A	C16-1625-48L	16.12-16.37	48	99111-2325A	C16-2325-50L	23.12-23.37	50		
99111-1650A	C16-1650-48L	16.37-16.62	48	99111-2350A	C16-2350-50L	23.37-23.62	50		
99111-1675A	C16-1675-48L	16.62-16.87	48	99111-2375A	C16-2375-50L	23.62-23.87	50		
99111-17A	C16-1700-51L	16.87-17.12	51	99111-24A	C16-2400-50L	23.87-24.12	50		
99111-1725A	C16-1725-51L	17.12-17.37	51	99111-2425A	C16-2425-50L	24.12-24.37	50		
99111-1750A	C16-1750-51L	17.37-17.62	51	99111-2450A	C16-2450-50L	24.37-24.62	50		
99111-1775A	C16-1775-51L	17.62-17.87	51	99111-2475A	C16-2475-50L	24.62-24.87	50		
				99111-25A	C16-2500-50L	24.87-25.12	50		



ER16 i-Center 中心鑽

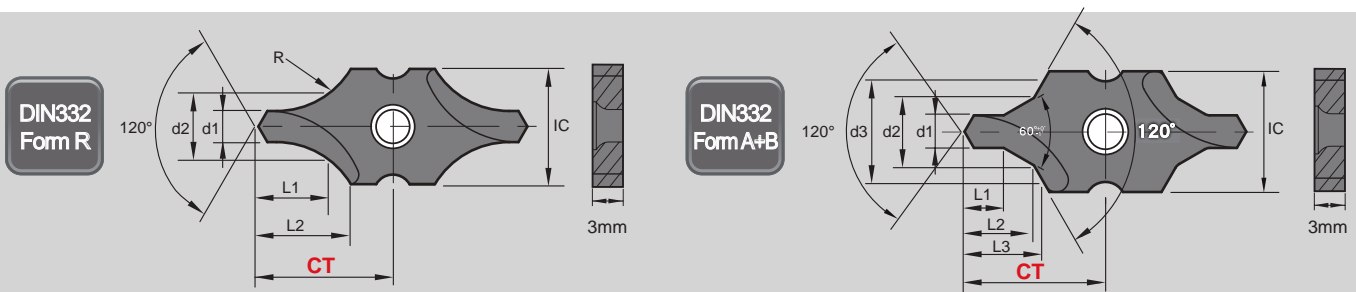

▶ DIN332 Form R 型刀片

IC	訂購編號	鍍層	材質	d1	d2	L1	L2	R	CT ±0.025
10	I9MT1003R0100- NC2057	AlTiN + TiSiN	P35	1.00	2.12	2.16	4.72	2.8	12.35
	I9MT1003R0125- NC2057			1.25					
	I9MT1003R0150- NC2057			1.50					
	I9MT1003R0160- NC2057			1.60					
	I9MT1003R0200- NC2057			2.00	4.25	4.45	6.50	5.65	
	I9MT1003R0250- NC2057			2.50					
	I9MT1003R0300- NC2057			3.00					
	I9MT1003R0315- NC2057			3.15					



▶ DIN332 Form A+B 型刀片

IC	訂購編號	鍍層	材質	d1	d2	d3	L1	L2	L3	CT ±0.025
10	I9MT1003B0100- NC2057	AlTiN + TiSiN	P35	1.00	2.12	3.15	1.3	2.21	2.51	12.35
	I9MT1003B0125- NC2057			1.25						
	I9MT1003B0150- NC2057			1.50						
	I9MT1003B0160- NC2057			1.60						
	I9MT1003B0200- NC2057			2.00	4.25	6.30	2.5	4.39	4.98	
	I9MT1003B0250- NC2057			2.50						
	I9MT1003B0300- NC2057			3.00						
	I9MT1003B0315- NC2057			3.15						

▶ 本體刀桿與零配件 • G6.3 / 10,000 r.p.m. • 含中心出水孔

IC	規格編碼	本體刀桿	ØD	L	螺絲	扳手
10	99816-IC10BH		16	45	NS-25060 0.9Nm	NK-T7

ERgo 螺母套組		ERgo 螺母			高強度 ERgo 拉鞘			L 型扳手	ERgo 螺母扳手	
	* 包含螺母、拉鞘和L型扳手。		Ød	牙距	扭力		L	扭力		
ER 錐柄	訂購編號	訂購編號	Ød	牙距	扭力	訂購編號	L	扭力	訂購編號	訂購編號
ER16	99816-M19S	99816-M19	25	M19xP1.0	30 Nm	NS-50025	25	5 Nm	NK-LW3	99816-SP28
	99816-M22S	99816-M22	28	M22xP1.5	30 Nm	NS-50028	28	5 Nm		

9

ERgo

技術規範

► 注意事項

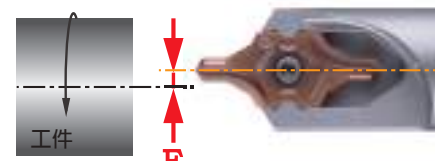
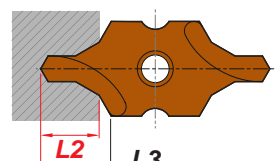
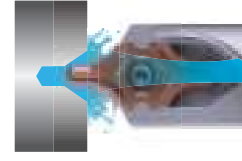
 <p>1</p> <p>中心沒有對齊 E 必需 < 0.02mm.</p>	 <p>2</p> <p>刀片 A+B 型 當加工深度到達L2時，降低轉速30%，並且保持一樣的機台進給。</p>	 <p>3</p> <p>建議使用中心出水</p>
--	---	--

► 切削資料

- 建議一開始使用時，feed rate 請使用中間數值。
- 使用“ d1” 值與切削速 Vc 於資料表中計算機台轉速” S” (r.p.m)。
- “ F” 進給率計算 F = S x F = IPR X r.p.m.

工件材質	Vc (m/min.)		d1									
			Ø1	Ø1.25	Ø1.50	Ø1.60	Ø2.0	Ø2.50	Ø3.0	Ø3.15		
P 低碳鋼 C<0.3%	< 80	S r.p.m.	2000 ~ 10000	2000 ~ 10000	1800 ~ 9000	1600 ~ 8000	1600 ~ 8000	1400 ~ 7000	1300 ~ 6500	1200 ~ 6000	●	○
		f mm/rev.	0.01 ~ 0.04	0.01 ~ 0.04	0.01 ~ 0.05	0.02 ~ 0.05	0.02 ~ 0.06	0.03 ~ 0.1	0.03 ~ 0.11	0.03 ~ 0.12		
	< 70	S r.p.m.	2000 ~ 9000	2000 ~ 9000	1800 ~ 8000	1600 ~ 7200	1600 ~ 7200	1400 ~ 6300	1300 ~ 6000	1200 ~ 5400	●	○
		f mm/rev.	0.01 ~ 0.04	0.01 ~ 0.04	0.01 ~ 0.05	0.02 ~ 0.05	0.02 ~ 0.06	0.03 ~ 0.1	0.03 ~ 0.11	0.03 ~ 0.12		
低合金鋼 C<0.3%	< 65	S r.p.m.	2000 ~ 8000	2000 ~ 8000	1800 ~ 7000	1600 ~ 6400	1600 ~ 6400	1400 ~ 5600	1300 ~ 5200	1200 ~ 4800	●	○
		f mm/rev.	0.01 ~ 0.03	0.01 ~ 0.03	0.01 ~ 0.04	0.01 ~ 0.04	0.01 ~ 0.05	0.02 ~ 0.08	0.02 ~ 0.10	0.03 ~ 0.1		
高合金鋼 C>0.3%	< 60	S r.p.m.	1000 ~ 6000	1000 ~ 6000	900 ~ 5500	800 ~ 4800	800 ~ 4800	700 ~ 4200	600 ~ 4000	600 ~ 3600	●	○
		f mm/rev.	0.01 ~ 0.02	0.01 ~ 0.02	0.01 ~ 0.03	0.01 ~ 0.03	0.01 ~ 0.04	0.02 ~ 0.06	0.02 ~ 0.08	0.03 ~ 0.08		
M 不鏽鋼	< 20	S r.p.m.	1000 ~ 3000	1000 ~ 3000	900 ~ 2700	800 ~ 2400	800 ~ 2400	700 ~ 2100	600 ~ 2000	600 ~ 1800	●	○
		f mm/rev.	0.003 ~ 0.01	0.005 ~ 0.015	0.005 ~ 0.02	0.005 ~ 0.02	0.01 ~ 0.025	0.01 ~ 0.03	0.01 ~ 0.04	0.02 ~ 0.05	≥ 5 bar	
N 鋁與非鐵金屬類	< 200	S r.p.m.	6000 ~ 20000	6000 ~ 20000	5000 ~ 18000	4800 ~ 16000	4800 ~ 16000	4200 ~ 14000	4000 ~ 13000	3600 ~ 12000	●	○
		f mm/rev.	0.01 ~ 0.03	0.01 ~ 0.03	0.01 ~ 0.04	0.01 ~ 0.04	0.01 ~ 0.04	0.02 ~ 0.05	0.02 ~ 0.05	0.02 ~ 0.06		

● 最好的 ○ 可能的

公制	
$S = \frac{Vc \times 1000}{\pi \times d}$	d1 = 直徑 -mm S = 刀具轉速 -r.p.m. Vc = 切削速度 -m/min.
F = S x f	f = mm/rev. F = mm/min.

英吋	
$S = \frac{(3.82 \times SFM)}{d}$	d1 = 直徑 -inch S = 刀具轉速 -r.p.m. SFM = Surface Speed -ft./min.
F = r.p.m. x IPR	f = IPR = inch/rev. F = inch/min.



ER16 i-Center 60°, 90°, 120° 中心孔& 埋頭孔

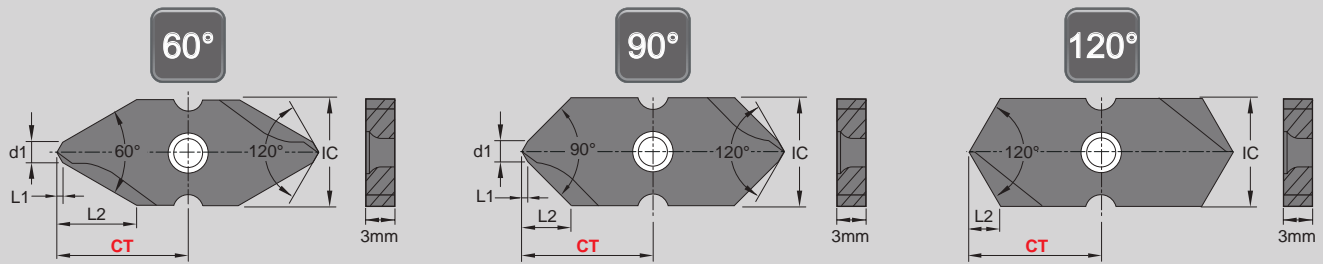

▶ 刀片



◀ 雙刃切削設計

- 雙刃切削，全磨削刀片，可提高加工穩定性。
- NC2057：可以在不使用冷卻潤滑劑的情況下進行鑽孔，或者在使用最小限度潤滑（MQL）時進行鑽孔。

IC	角度	訂購編號	鍍層	材質	d1	L1	L2		Dmax.	Tmax.	CT ±0.025
10	60°	I9MT1003CT060-NC2057	AlTiN+ TiSiN	P35	2	0.58	7.5		10	7.5	12.35
	90°	I9MT1003CT090-NC2057			2	0.58	4.6		10	4.6	
	120°	I9MT1003CT120-NC2057			-	-	2.9		10	2.9	

▶ 本體刀桿與零配件 • G6.3 / 10,000 r.p.m. • 含中心出水孔

IC	訂購編號	本體刀桿	ØD	L	螺絲	扳手
10	99816-IC10BH		16	45		

ERgo 螺母套組		ERgo 螺母			高強度 ERgo 拉鞘			L 型扳手	ERgo 螺母扳手
	* 包含螺母、拉鞘和L型扳手。		Ød						
ER 錐柄	訂購編號	訂購編號	Ød	牙距	扭力	訂購編號	L	扭力	訂購編號
ER16	99816-M19S	99816-M19	25	M19xP1.0	30 Nm	NS-50025	25	5 Nm	NK-LW3
	99816-M22S	99816-M22	28	M22xP1.5	30 Nm	NS-50028	28	5 Nm	

▶ 切削資料

工件材質	Vc (m/min)	中心孔			埋頭孔			
		f (mm/rev.)			Vc (m/min)	f (mm/rev.)	●	○
		60°	90°	120°				
P 低碳鋼 C<0.3% 中碳鋼 C>0.3% 低合金鋼 C<0.3% 高合金鋼 C>0.3%	120 ~ 250	0.04 ~ 0.20	0.15 ~ 0.25	0.10 ~ 0.30	120 ~ 250	0.20 ~ 0.50	●	○
	100 ~ 220	0.04 ~ 0.20	0.10 ~ 0.05	0.10 ~ 0.30	100 ~ 220	0.20 ~ 0.40	●	○
	100 ~ 200	0.03 ~ 0.16	0.08 ~ 0.20	0.10 ~ 0.25	100 ~ 200	0.15 ~ 0.40	●	○
	80 ~ 180	0.03 ~ 0.12	0.08 ~ 0.20	0.10 ~ 0.25	80 ~ 180	0.10 ~ 0.30	●	○
M 不鏽鋼	60 ~ 120	0.02 ~ 0.10	0.06 ~ 0.12	0.08 ~ 0.15	60 ~ 120	0.08 ~ 0.30	● ≥ 5 bar	○
N 鋁與非鐵金屬類	150 ~ 300	0.04 ~ 0.20	0.10 ~ 0.25	0.10 ~ 0.30	150 ~ 300	0.20 ~ 0.50	●	○

● 最好的 ○ 可能的

ER16 刀長設定器 *Patent Pending*

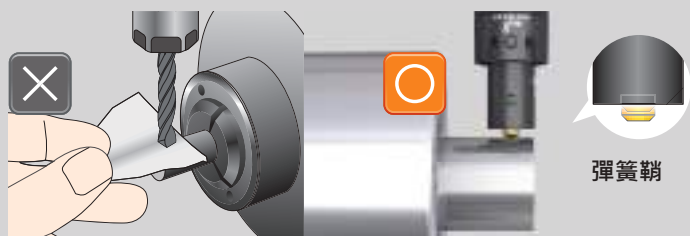

簡單、快速
刀具長度設定!

▶ 刀長設定器與零配件

- ERgo 刀長設定器是一款簡便的刀具長度記錄器，可在瑞士式自動車床或 CNC 車銑中心上設定刀具長度。
- 降低停機頻率並防止刀片尖端或工件損壞。

訂購編號	設定本體	L 扳手
99816-TP	 對焦刀 (用於刀具量測儀)	NK-LW15 (2 Nm) 

ERgo 螺母套組		ERgo 螺母			高強度 ERgo 拉鞘			L 型扳手	ERgo 螺母扳手	
	* 包含螺母、拉鞘和L型扳手。		$\varnothing d$							
ER 錐柄	訂購編號	訂購編號	$\varnothing d$	牙距	扭力	訂購編號	L	扭力	訂購編號	訂購編號
ER16	99816-M19S	99816-M19	25	M19xP1.0	30 Nm	NS-50025	25	5 Nm	NK-LW3	99816-SP28
	99816-M22S	99816-M22	28	M22xP1.5	30 Nm	NS-50028	28	5 Nm		

▶ 設定器使用步驟

* 注意雕刻的切削深度如果小於 0.1mm，則必須在更換新的刀片或切削刃時重新設定刀具長度。

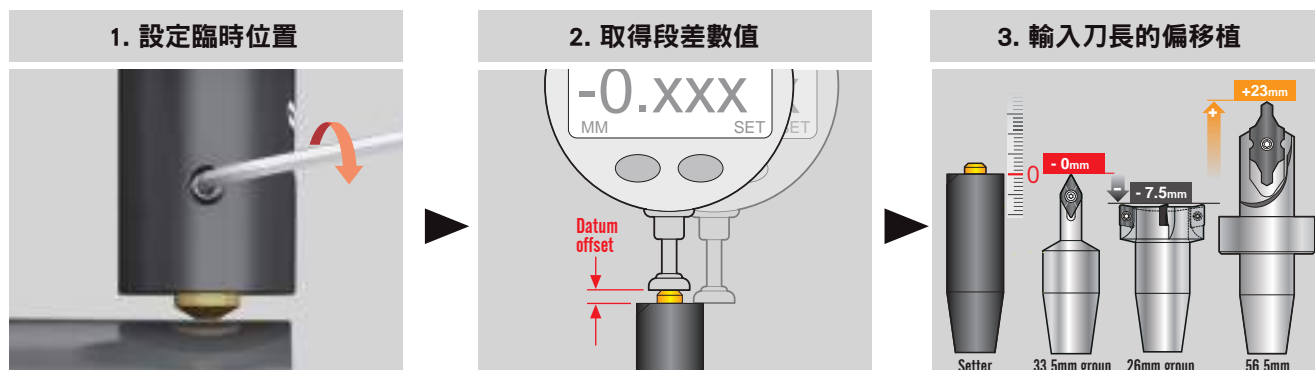

- 1: 移定設定器接觸加工表面。
- 2: 讓彈簧鞘深入 1 – 2mm 的深度。
- 3: 然後用側固螺絲固定。
- 4: 將鎖固之長度，寫入 CNC 控制器。

- 1: 量測段差。
- 2: 將段差數值寫入CNC控制器。

- 1: 寫入其他刀具跟刀長設定之段差長度。

組裝步驟

! 重新組裝或更換工具時，請清潔每樣零配件，確認他們都是乾淨的。

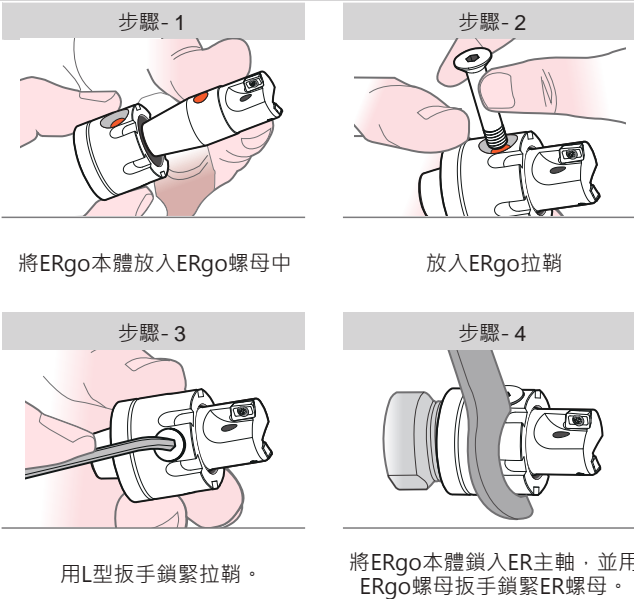

► 只要是ER11、ER16、ER20、ER25的主軸均適合使用。 >>

例如：瑞士型自動車床、車床、銑削機床或其他ER的刀柄。



- 快速更換且整個刀具長度超短。
- 適用於任何類型的動力刀座和筒夾夾頭。

► 性能 >>

工件材質	切削長度	刀具懸出長度	機器: HAAS VM-3, BT40 / 22.5KW					
S50C (碳鋼)	2000 mm	172 mm (by ER collet chuck)	Vc (m/min.)	S (r.p.m.)	f (mm/z)	F (mm/min.)	Ap (mm)	Ae (mm)
			80	2500	0.03	150	1.0	6.0
刀具	刀具磨損		表面粗糙度			切削音頻		
ERgo 刀霸	[Bar chart showing lowest wear]		[Bar chart showing lowest roughness]			[Bar chart showing lowest vibration]		
捨棄式銑刀	[Bar chart showing higher wear]		[Bar chart showing higher roughness]			[Bar chart showing higher vibration]		
端銑刀	[Bar chart showing highest wear]		[Bar chart showing highest roughness]			[Bar chart showing highest vibration]		

ERgo ER16 套組- 初次使用者的最佳選擇。

▶ 不包含刀片 >>

螺母	刀具種類	訂購編號	內容
ERgo ER16 M19 螺母	雕刻刀 & 去毛邊刀	99816-X060-M19S	ERgo 本體刀桿 x 1 ERgo M19 螺母 x 1 高強度 ERgo 拉鞘 x 1 3mm L 扳手 x 1 刀片扳手 x 1  * 不包含刀片
	刀霸	99816-10A06-M19S	
		99816-12A06-M19S	
		99816-16A06-M19S	
		99816-20A06-M19S	
		99816-25A06-M19S	
		99816-32A06-M19S	
	中心鑽	99816-IC10BH-M19S	
刀長設定器	99816-TP-M19S		
ERgo ER16 M22 螺母	雕刻刀 & 去毛邊刀	99816-X060-M22S	ERgo 本體刀桿 x 1 ERgo M22 螺母 x 1 高強度 ERgo 拉鞘 x 1 3mm L 扳手 x 1 刀片扳手 x 1  * 不包含刀片
	刀霸	99816-10A06-M22S	
		99816-12A06-M22S	
		99816-16A06-M22S	
		99816-20A06-M22S	
		99816-25A06-M22S	
		99816-32A06-M22S	
	中心鑽	99816-IC10BH-M22S	
刀長設定器	99816-TP-M22S		

需求表

▶ 公司 >>

▶ 想挑戰或改善事項 >>

- 下列資訊需與客戶討論時確認

使用機器		原有刀具	
機台種類		切削速度	<input type="checkbox"/> HSS
主軸轉速	Max. r.p.m.		<input type="checkbox"/> 鎢鋼
主軸馬達	<input type="checkbox"/> KW <input type="checkbox"/> HP		m/min. SFM
冷卻	<input type="checkbox"/> NO	其他	
	<input type="checkbox"/> If yes, <input type="checkbox"/> 外部的 <input type="checkbox"/> 內部的		
工件材質	bar(psi)	進給率	mm/rev. inch/rev.

▶ ER 錐柄尺寸 >>

- MOQ: 2 pcs / Lead Time: 10 ~ 12 Weeks.

樣式

A B C

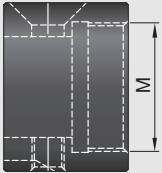
Cutter Dia. : (ØDc)		
L1 : (最大值請見右下表格)	θ : E :	
中心出水	<input type="checkbox"/> 需要 <input type="checkbox"/> 不需要	
ER 螺母	<input type="checkbox"/> N9ER16-M19 <input type="checkbox"/> N9ER16-M22 <input type="checkbox"/> N9ER20-M24 <input type="checkbox"/> N9ER20-M25 <input type="checkbox"/> N9ER25-M32	
螺母規格 	M	
	<input type="checkbox"/> ER16	M19xP1.0
	<input type="checkbox"/> ER16	M22xP1.5
	<input type="checkbox"/> ER20	M24xP1.0
	<input type="checkbox"/> ER20	M25xP1.5
<input type="checkbox"/> ER25	M32xP1.5	

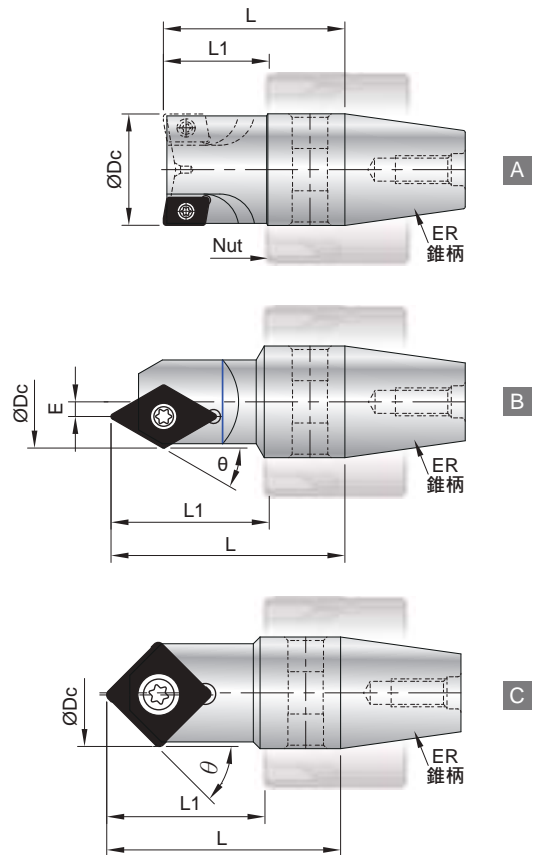

ER 錐柄規格			
ØDc	L1 Max.	L Max.	ER 錐柄
10 ~ 32	22	34	ER16
	26.5	40	ER20
	30.5	50	ER25

延長桿

適用於鎖牙式的星艦定位鑽，NC車銑萬用鑽，密齒倒角刀，電腦打洞刀，刀霸銑刀，微調精搪刀頭...等

► 鋼柄 >>

- T是最大可加工深度
- 中心出水型

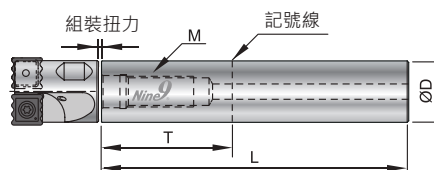

訂購編號	Part No.	ØD	T	L	M	組裝扭力
99801-08S	BC08-060M04S	8	10	60	M4xP0.7	3.5 Nm
99801-10S	BC10-075M05S	10	25	75	M5xP0.8	6.5 Nm
99801-12S	BC12-075M06S	12	25	75	M6xP1.0	11.0 Nm
99801-14S	BC14-090M08S	14	30	90	M8xP1.25	25.0 Nm
99801-16S	BC16-090M08S	16	35	90	M8xP1.25	25.0 Nm
99801-18S	BC18-100M10S	18	40	100	M10xP1.5	50.0 Nm
99801-20S	BC20-100M10S	20	40	100	M10xP1.5	50.0 Nm
99801-25S	BC25-120M12S	25	50	120	M12xP1.75	60.0 Nm
99801-32S	BC32-150M16S	32	65	150	M16xP2.0	-

► 鎢鋼接桿 >>

- T是最大可加工深度
- 中心出水型
- 加長型接桿，需調整加工速度

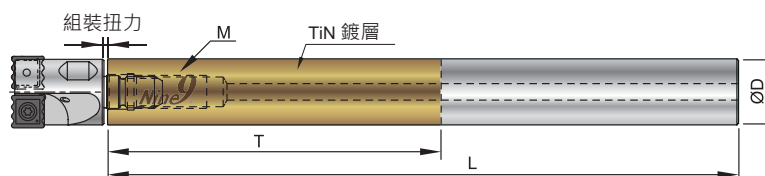

訂購編號	Part No.	ØD	T	L	M	組裝扭力
99801-08W	BC08-075M04W	8	25	75	M4xP0.7	3.5 Nm
99801-10W	BC10-100M05W	10	50	100	M5xP0.8	6.5 Nm
99801-12W	BC12-100M06W	12	60	100	M6xP1.0	11.0 Nm
99801-14W	BC14-120M08W	14	70	120	M8xP1.25	25.0 Nm
99801-16W	BC16-150M08W	16	80	150	M8xP1.25	25.0 Nm
99801-18W	BC18-150M10W	18	90	150	M10xP1.5	50.0 Nm
99801-20W	BC20-200M10W	20	100	200	M10xP1.5	50.0 Nm
99801-25W	BC25-200M12W	25	125	200	M12xP1.75	60.0 Nm

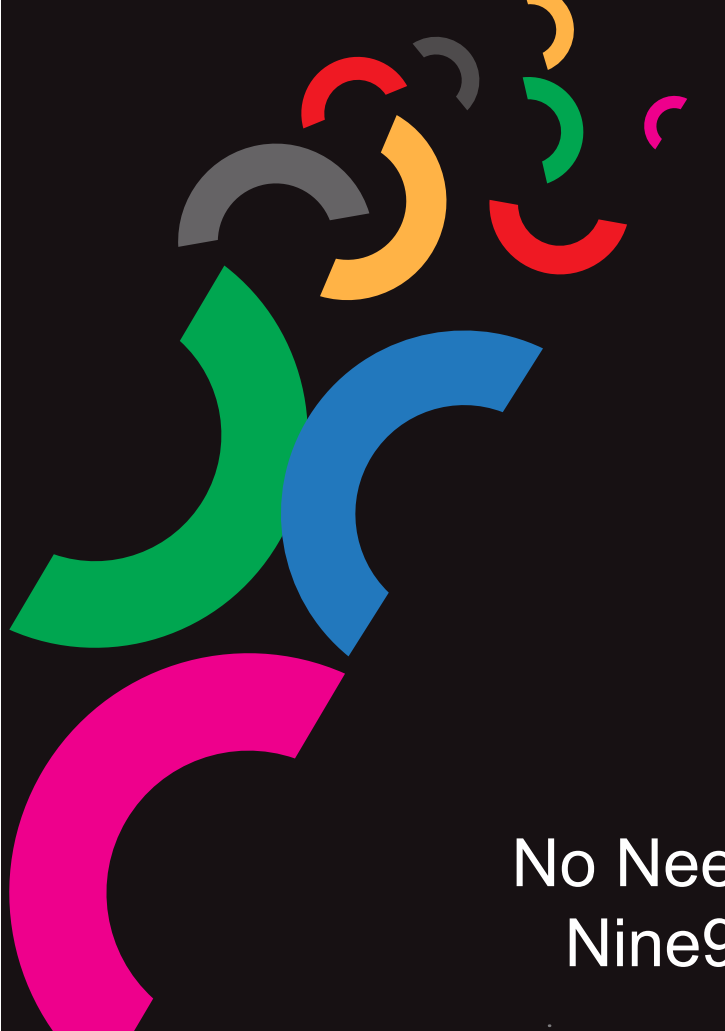

No Need To Choose
Nine9 Does It All



Nine9[®]
耐久切削工具有限公司
NINE-9 CUTTING TOOLS CO., LTD.

台中市太平區永豐路85巷21號
No. 21, Lane 85, Yongfeng Rd.,
Taiping Dist., Taichung City.

E-mail: n9n9@ms16.hinet.net
TEL: 886-4-2270-7722 (代表號)
FAX: 886-4-2278-9766
<http://nine9tool.com>